



INERTGAS
TECHNOLOGY

Operating Manual

- Gas Purifier
MB20/MB200 G
- Workstation
LABmaster Pro sp/dp
- MOD Box with
MB20/MB200 G

with Touch Panel TP700

Gas Purification Systems

- Gas Purifier MB20/MB200 G
- Workstation LABmaster Pro sp/dp
- MOD Box with MB20/MB200 G

Touchpanel TP700

Operating Manual

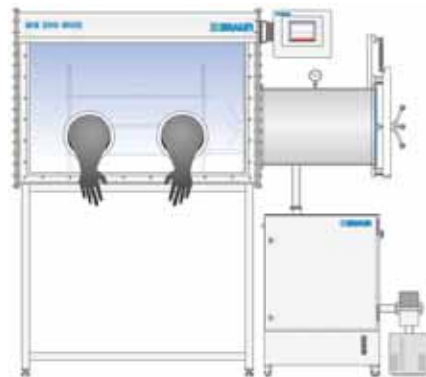
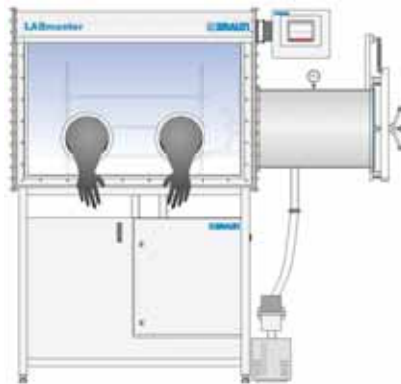

Original
Operating Manual V 4.1 - 06/2014

Gas Purifier MB20/MB200 G
Workstation LABmaster sp/dp
MOD Box with MB20/MB200 G

Touchpanel TP700

M. Braun Inc.
14 Marin Way
Stratham, NH 03885

Website www.mbraun.com

Phone: +1 (603) 773-9333
Fax: +1 (603) 773-0008
E-Mail: service@mbraunusa.com



Inertgas Systems

Operating Manual

- 1 Information**
- 2 System**
- 3 Safety**
- 4 Preparation and Installation**
- 5 Structure of the Controller and Touch Panel**
- 6 Basic Principles of Operating Modes**
 - 6 A ECO-Mode *
- 7 Operation of the Gas Purifying System**
- 8 Operation of the Inert Gas Box**
 - 8 A Analyzer *
- 9 Operation of the Antechamber**
- 10 Additional Components**
- 11 Trouble Shooting**
- 12 Inspection and Maintenance**
- 13 Spare Parts**
- 14 Third Party Documentation**
- 15 Certificates**
- 16 Electrical / Wiring Diagrams**

** Optional additional chapters*

Annexes:

*PDF of the Manual and Third Party
Documentation (CD-ROM or USB-Stick)*

1.1	System information.....	1-2
1.1.1	<i>Scope of delivery.....</i>	1-3
1.1.2	<i>Identification Sticker.....</i>	1-3
1.1.3	<i>Safety markings on the system.....</i>	1-4
1.2	Use of this operating manual.....	1-6
1.2.1	<i>Before use of the inert gas system.....</i>	1-6
1.2.2	<i>While the inert gas system is in use.....</i>	1-6
1.2.3	<i>Markings in this operating manual.....</i>	1-6
1.2.4	<i>Safety instructions.....</i>	1-6
1.3	Liability.....	1-9
1.4	Warranty.....	1-9
1.5	Service address.....	1-10

System information

1 Information about the Operating Manual

1.1 System information

This operating manual belongs to the following M.Braun system:

Designation / Type:

Serial number(s):

System administrator / User:

Other system information:

.....

Notes:

.....

.....

.....

.....

.....

.....

.....

.....

.....

.....

.....

.....

.....

.....

.....

.....

.....

.....

.....

Scope of delivery

1.1.1 Scope of delivery

The scope of delivery is defined in the contractual agreements according to order confirmation and follow-ups.

This operating manual describes - regardless of the scope of delivery - a typical standard system with

- Inert gas box with antechamber
- Gas purification system
- PLC controller with touch panel
- Sensors for monitoring of the box/antechamber atmosphere

Optional components / functions are marked in the operating manual, such as, e.g.

- Solvent filter
- Vacuum pump
- Antechamber cover lock

See also *Chap. 10 Accessories and customer-specific components.*

1.1.2 Type plate

Rear side of the system: examples of type plates of standard systems

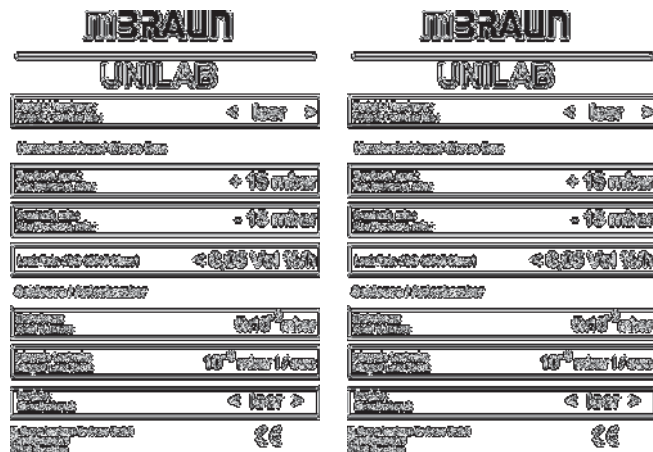

Project-specific systems deviate depending on their equipment.

System information

1.1.3 Safety markings on the system

Devices may bear the following warnings and mandatory signs:



General warning

Indicates possible personal injury, possible damage to the system or accessories and a possible compromising of the process materials!



Risk of hazardous electrical voltage

Indicates possible personal injury due to electrical voltage such as uncontrolled muscle reactions, crippling, burns or death!

Use caution! There is danger to life and limb!



Risk of gases under pressure

Indicates possible personal injury, possible damage to the system or accessories due to gas containers or gas lines!



Risk of hot surface

Do not touch hot surface! Risk of burning!

The markings in this operating manual refer only to devices and components from **MBRAUN**. Other manufacturers' components may be marked with other safety instructions that are not explained in this operating manual. See *supplier documentation Chap. 14*.

Duties of the Operator

The system operator is obligated to attach safety markings to the system if dangers results from system expansions or processes. This applies especially to the use of dangerous or toxic chemicals.



DANGER

Risk of injury and damage!

All safety markings on the system must always be visible and legible!

Scope of delivery

Position of the safety markings on the system (Standard)

Antechamber:



Control cabinet:

with frequency converter:

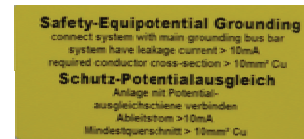

without frequency converter:

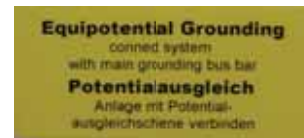

Vacuum pump:



On the side:

(see also supplier documentation)

WARNINGS

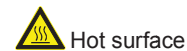

Use of this operating manual

1.2 Use of this operating manual

1.2.1 Before use of the inert gas system

Anybody who works on the system must read, understand, and follow the operating manual while performing any necessary work: this includes transport, storage, installation, commissioning, and servicing.

- ▶ Read the instructions completely before using the system in order to avoid improper operation and injuries.
- ▶ In case of questions, please contact **MBRAUN** Service.

1.2.2 While the inert gas system is in use

Always keep the operating manual within reach of the system.

Follow all safety instructions in this manual

-
- ! **MBRAUN** inert gas systems are subject to constant safety-technical enhancement. Therefore it can be that the actual system components differ from those described in the operating manual. In case of doubt, be sure to contact the manufacturer.
-

1.2.3 Markings in this operating manual

Sequence of actions:

- > Prerequisite
- ▶ Action
- Intermediate result / consequence
- ⇒ Result

-
- ! Information and tips (action-related)
-

Background information

Numbering:

00000-1 Number in panel image

1.2.4 Safety instructions

The safety instructions in this operating manual comply with the guidelines 2006/42/EC, DIN EN ISO 12100-1 and ISO EN 82079, ISO 14121-1, and 2. They are used analogously to ANSI Z535.6.

Scope of delivery

The following safety instructions are used in this operating manual:



DANGER

Severe to life-threatening injuries. Occurrence very likely to certain.



WARNING

Severe to life-threatening injuries. Occurrence possible.



CAUTION

Slight to moderate injuries. Occurrence possible.

Marking of the type of danger (optional)

If necessary, the type of danger may be marked:

Type of danger – standard systems



Risk of hazardous electrical voltage!

Indicates possible personal injury due to electrical voltage such as uncontrolled muscle reactions, crippling, burns or death!

Use caution! There is danger to life and limb!



Risk of suffocation



Hot surface



Mechanical hazard!

Indicates injuries to hands and arms due to crushing, bending, cutting, cutting movements, and catching in rotating equipment.

Type of danger – in case of customer-specific equipment/processes



Risk of explosion!

Indicates possible personal injuries due to the handling of flammable or explosive gases.

Use of this operating manual

Warnings about property damage

NOTICE Note about property damage. Occurrence possible.

Instructions



Wear full breathing protection mask!



Wear protective goggles!



Wear protective gloves!

Type and function of the safety instructions

The safety instructions in this operating manual are used as:

- Basic safety instructions. The essential safety aspects are summarised in the basic safety instructions chapter. They serve as safety instructions before using the inert gas system.
- Preceding safety instructions. At the beginning of a chapter/a sequence of instructions, there are warning signs and signal words. The preceding safety instructions warn about risks of injury that may arise during a sequence of actions.
- Integrated safety instructions. Directly preceding the action are risks of injury that arise during one or several related action(s). The warnings are integrated into the action sequence, and either marked with a signal word or danger sign.

Scope of delivery

1.3 Liability

The contractually agreed-upon liability conditions apply. The manufacturer assumes no liability for product damage or personal injury that results from improper handling or the failure to follow operating manual or safety guidelines.

Designations used in this operating manual may be trademarked product names; these serve only the purpose of identification.

Changes and modifications

The warranty and warranty claims are voided by non-approved changes and modifications!

- Changes and modifications may only be made by **MBRAUN** specialised personnel. Exceptions require written confirmation.
- The manufacturer assumes no liability for damage due to authorised system modifications or software updates if these were performed improperly or the damage arose due to improper operation because of neglected updating of the operating manual. There are generally no liability claims for unauthorised system modifications.

1.4 Warranty

The warranty is only valid for the contractually-equipped system. Warranty claims are voided under the following conditions:

- Unauthorised changes to the system without the manufacturer's permission
- Improper operation of the system
- Improper use of the system
- Inadequate maintenance of the system
- Carelessness with respect to the system supply
- Use of other manufacturers' components without permission of the system manufacturer
- Changes of programme and system settings without the manufacturer's permission (outside of the parameter limits described in this operating manual).



Valid both for individual components as well as for complete systems!

Service address

1.5 Service address

M. Braun Inc.

14 Marin Way

Stratham, NH 03885

[Tel:+1 \(603\) 773-9333](tel:+16037739333)

Fax:+1 (603) 773-0008

E-mail: service@mbraunusa.com

Internet: www.mbraun.com



2.1	System and system types	2-2
2.1.1	System	2-2
2.1.2	System types.....	2-3
2.1.3	System controller.....	2-6
2.2	System components gas purifier	2-7
2.2.1	Design and function.....	2-7
2.2.2	Operation in one-purifier system and two-purifier system	2-8
2.2.3	Operation with solvent filter (LMF) - (Option)	2-9
2.3	System component inert gas box	2-10
2.3.1	Design and function.....	2-10
2.3.2	Functions for the control of the box atmosphere	2-13
2.3.3	Functions for pressure regulation of the box	2-14
2.4	System component antechamber	2-16
2.4.1	Structure and functions	2-16
2.4.2	Operation of vacuum antechamber.....	2-19
2.4.3	Principle of the transfer process vacuum antechamber.....	2-20
2.5	System component vacuum pump	2-22

2 System description

2.1 System and system types

2.1.1 System

A complete **MBRAUN** inert gas system consists of the main components

- Gas purifier (with vacuum pump + blower)
- Inertgas box
- Antechamber

It serves the maintenance of a specific atmosphere of inert gas (typically nitrogen or argon) with an oxygen and water vapor content of < 1 ppm (V).

The gas purifying system is used primarily to protect products. The highly-pure atmosphere allows work with oxygen and moisture-sensitive materials and processes.

Using the antechamber and antechamber processes, it is possible to transfer materials between the box and environment without disturbing the box atmosphere.

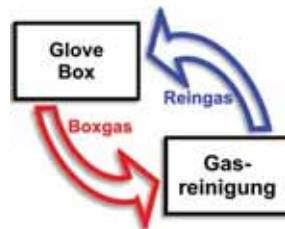

The quality of the inert gas atmosphere in the box is maintained through circulation of the box atmosphere via the purifiers of the gas purifier.

System and system types

2.1.2 System types

2.1.2.1 Inertgas box with UNilab Plus SP/ DP gas purifier

The Unilab plus sp/dp workstation offers a compact system with inert gas box and adjacent gas purifier. The system consists of the following components:

- Typical components of the system
- Electrical + controller / Control and display elements

Main component	Nr.	Designation	see chapter
Inertgas box	(1)	Inertgas box	8
	(2)	Particle filter (input and output filter)	
	(3)	Pane with gloveport feedthroughs/ gloves	
	--	Sensors (in the piping - without Fig.)	8

System and system types

Main component	Nr.	Designation	see chapter
Controller	(4)	Touch panel	5
	(12)	Foot switch for regulation of the operating pressure	
Antechamber	(6) + (7)	Main antechamber / mini-antechamber	9
	(5) + (8)	Manometer	
	(9)	Vacuum pump (VP)	
Control cabinet	(10)	Main switch	
	(11)	Control cabinet	
Gas purifier	(13)	Flowmeter (for regeneration)	7
	(14)	Purifier (RKM) (gas purifier H ₂ O + O ₂) /Solvent filter (LMF) (optional)	7

Additional functions (optional):

Standard system	with additional functions (optional)		see chapter
Unilab Pro/Plus SP/DP	-BS	Box purging	9.5
	-LMF	Solvent Filter	7.4
	-BS-LMF	Box purging + LMF	9.5 + 7.4
	-LMF-reg	Regenerative LMF	7.4
	-BS-LMF-reg	Box purging + regenerative LMF	9.5 + 7.4

System and system types

2.1.2.2 Modular inert gas box with external UNilab Plus SP/ DP gas purifier

The Unilab Pro modular system with adjacent gas purifier can optionally be expanded into a multi-box system and equipped with special equipment.



Set-up of the gas purifier in modular systems *)

Components not identified: see Fig. above

*) The numbering is analogous to the Fig. shown above.

Main component	Fig. no.	Designation
Inertgas box	(1)	Modular inert gas box

2.1.2.3 Special equipment and functions

- Additional functions in optional chapter (A..) for gas purifier, inert gas box, and antechamber
- Additional components in Chapter 10 (A..) optionally with separate operating manual (e.g. spin coater, evaporators, etc.)
- Special equipment from third-party suppliers: *See Chapter 15, Supplier documentation.*

System and system types

2.1.3 System controller

2.1.3.1 PLC controller

The entire system is controlled by a PLC controller. Configuration and operation is done using a TFT 70 control panel.

The measurement values of sensors and pressure management devices provide the basis for the parameters of the controller and the monitoring of the system.

See Chapter 5, Controller

2.1.3.2 Valve operation

- The gas flow and pressure are controlled to some extent using valves (e.g. control valves with various drives, e.g. electro-pneumatic, electromagnetic, etc.)
- Manually-activated valves (e.g. manual valves gas supply, manually-operated mini-antechamber)

System and system types

2.2 System components gas purifier

The gas purifier serves to remove moisture and oxygen from the box atmosphere, which with the help of the circulation is fed into the purifiers. Optional: removal of solvents.

2.2.1 Design and function

The gas purifier consists of the following main components

→ Gas purifier input
(gas from the box)

→ Gas purifier output
(purified gas in the box)

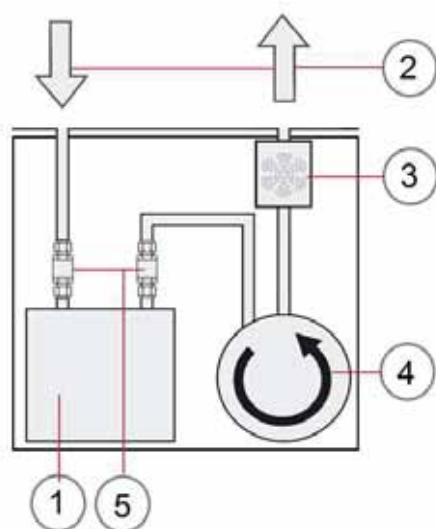

Nr.	Designation	Function
(1)	H2O and O2 purifier	Through chemical reaction, the purifier filling removes oxygen and absorbs water vapor from the recirculated box atmosphere.
--	Solvent filter (LMF) - optional	The solvent filter removes solvent vapors from the recirculated box atmosphere and protects the H2O/O2 purifier against the adverse effects of solvents.
(2)	--	Gas flow (circulation between gas and gas purifier)
(3)	Cooling /(heat exchanger)- optional	Gas compression and electrical heat sources heat up the inert gas. The gas cooling removes the heat before the gas is fed back into the inert gas box.
(4)	Blower (circulation unit)	Circulation of the box atmosphere between gas purifier and box
(5)	Valves	The gas flow is controlled by electromagnetic valves and the PLC controller.

System components gas purifier

Circulation

The oxygen and moisture-laden box atmosphere is recirculated continuously via the purifier using the blower.

Here special fill materials in the purifier remove oxygen through chemical reaction and they absorb water vapor from the box atmosphere. The purified gas is fed back into the box.

Regeneration

After longer use in circulation operation, the fill material of the purifier is saturated. This is indicated by an increase of the H_2O/O_2 concentration in the box.

Therefore, the purifiers must be regenerated regularly. In a controlled, automatic procedure, the purification capacity is restored using regeneration gas.

2.2.2 Operation in one-purifier system and two-purifier system

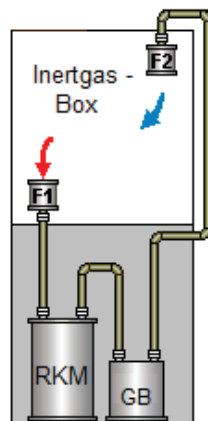

System with one purifier:

(Unilab SP)

Operating mode:

The gas purifier is either in circulation operation or in regeneration operation.

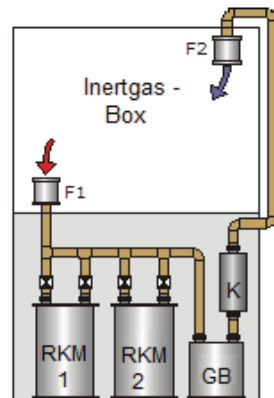

Systems with two purifiers

(Unilab DP):

While one purifier (RKM 1 or RKM 2) is in regeneration operation, the box atmosphere can be circulated and purified by the second purifier.

In systems with two purifiers, a continuous circulation of the box atmosphere is also possible during regeneration.

RKM purifier GB Blower Heat exchanger (optional)

System and system types

2.2.3 Operation with solvent filter (LMF) - (Option)

Depending on the hazardous materials to be filtered (e.g. organic polar or unpolar solvents, acid gases), the **MBRAUN** solvent filters are filled with various filter media. The filter efficiency and absorption capacity depend on the qualities of the solvents (e.g. boiling point, vapor pressure, chemical nature), on the properties of the filter medium, as well as on the operating conditions (ambient temperature, process gas).

Function in circulation operation

A solvent filter removes solvent vapors from the box atmosphere and protects the purifier RKM against the adverse effects of solvents.

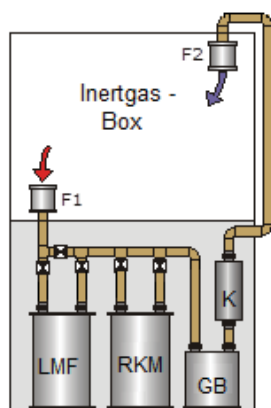

Solvent filter principle

With use of a solvent filter (LMF), the box atmosphere loaded with solvent vapors initially circulates via the LMF, where the solvents are filtered out.

Only after that is the pre-purified box atmosphere fed into the purifier (RKM), purified, and fed back into the box.

Optional: In bypass operation, the circulation via the LMF can be interrupted.

LMF	Solvent filter	RKM	Purifier (H2O/ O2)GB	Blower	K
	Heat exchanger (optional)				

Regenerative LMF (optional)

The regeneration takes place according to the same principle as for the one and two-purifier systems (O2 and H2O).

Please note the instructions in Chap. 4 Installation.

Solvent filter (LMF) – Systems

Operation	Principle	Filter medium
Manual LMF manual valves	Requires periodic replacement of activated carbon.	Activated carbon
LMF Reg. - 1-filter system, PLC controlled, operated on the touch panel	Regenerative	Molecular sieve

Operation of the solvent filter: See Chap. 7 Gas purifier

System component inert gas box

2.3 System component inert gas box

An inert gas box is a container that is hermetically sealed off from the surrounding space. Inside, a defined atmosphere is generated and maintained, which typically consists of inert gases such as nitrogen or argon.

2.3.1 Design and function

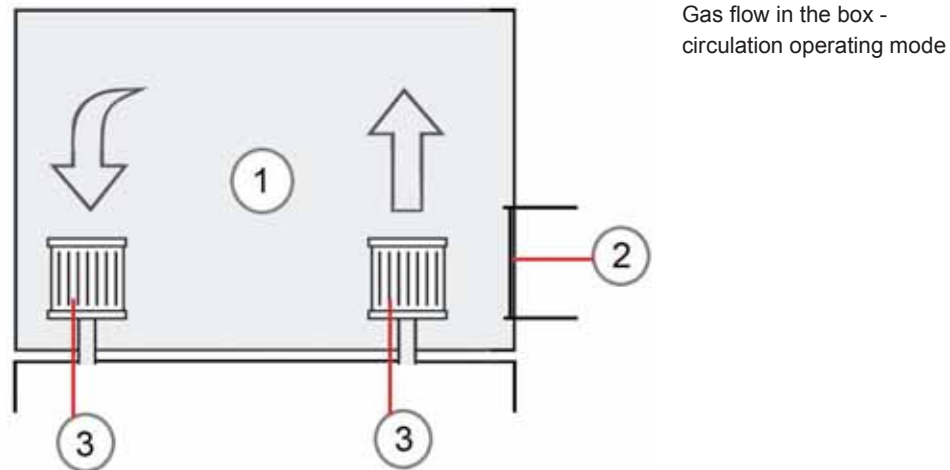

Nr.	Designation	Function
(1)	Inertgas box	Work area with specific inert gas atmosphere for the processing of oxygen and moisture-sensitive substances and materials.
	Individual box	Can be designed as individual box and/or as
	MOD box	Modular box, designed for expansions / two-box systems
	Pipework	Connection to the gas purifier / media supply / Discharge of exhaust air; system-specific; Optional equipment: sensors, particle filter
(2)	Antechamber	Connection box-outside: loading and unloading of material box (see description below)
	Touch panel	External on the box: controller and monitoring of the entire system
(3)	Particle filter	HEPA filter in gas feed and discharge protect the gas purifier against contamination from processes in the box and keep particles from the gas purifier away from the workspace in the inert box.

System and system types

Other equipment (no figure)

Nr.	Designation	Function
--	Sensors	Measurement of the box pressure and the box atmosphere (moisture and oxygen) optional: additional substances and gases / solvents Provide output data for the monitoring of (PLC-controlled) processes of the inert gas system.
--	Box window	The box window, made of polycarbonate partitions the box inside and provides access via gloveport feedthroughs.
--	Gloveport feedthroughs	Access from the outside to the work area in the box for handling of process materials and instruments.
--	Gloves	Butyl gloves have low gas permeability and high tolerance of chemical process materials. Optional: additional materials are available.
--	Lighting	Exterior mounted lights light up the working area glare-free
--	Media feedthroughs	Feedthroughs for external media supply in the box: (gas, electricity, USB interface ...) without Fig.
--	Shelves	Storage of process materials / products without Fig.

2.3.1.1 Gloves of the box

For gloves for the standard box, **MBRAUN** uses only butyl gloves.

Specification:

Property	Description
Temperature range	-40 °C to +90 °C
Permeability (P) for gases and water vapor	$\frac{10^{-9} \text{ cm}^3 \cdot \text{gas}}{\text{s}}$ See below for definition
Chemical resistance	Good resistance against acids and bases (for additional details: see data sheet)

Permeability constant (P)

Gas flow through 1 cm thick material at standard temperature and pressure. Measured rate 10-9cm³ gas/s.

System component inert gas box

Comparison of permeability for gases and water vapor (butyl, hypalon, neoprene)

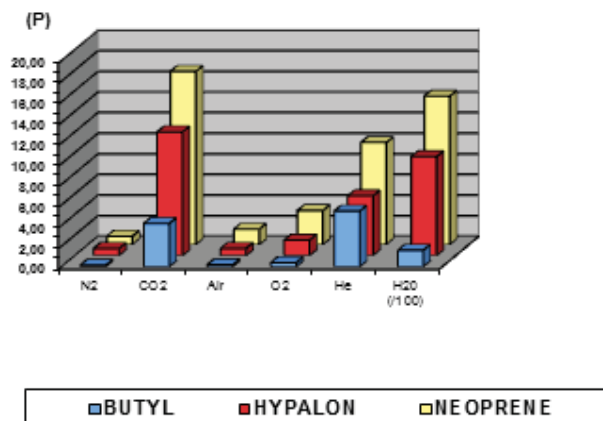

! For use in higher temperature ranges, butyl gloves with hypalon coating are available. Ask **MBRAUN** Service.

2.3.1.2 Particle filter (box)

Inert gas boxes are equipped with dust filters. The dust filters are on the gas inlet and gas outlet. The inlet filter ensures optimal particle-free gas supply.

Dust filters protect the gas purifier against particles that can be generated due, for example, to ongoing processes in the inert gas box.

Technical Data

The filter types that are used in **MBRAUN** inert gas box systems demonstrate the following characteristics:

The standard filter corresponds to the HEPA format (classification H14*) – this corresponds to the filtering of 99.995% of the particles with a diameter of up to 0.2 µm.

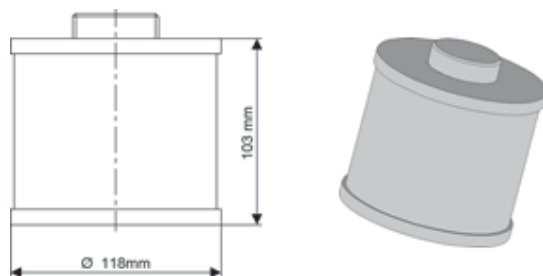

! Finer filter types are available (e.g. classification U15 – filtering of 99.9995% of the particles). Ask **MBRAUN** Service.*) Depending on the working condition

System and system types

2.3.2 Functions for the control of the box atmosphere

2.3.2.1 Sensor monitoring (H2O and O2)

For the monitoring of the oxygen and moisture content in the box atmosphere, standard systems are equipped with the following sensors:

Type	Description	Measuring range
MB-OX-SE-1	Oxygen sensor	0 - 1000 ppm
MB MO-SE-1	Moisture sensor	0 - 500ppm

Specification of the sensors: See attachment

The sensors are installed in the pipework. The PLC controller evaluates the values displayed and controls the processes according to the parameters input (see Chapter 5).

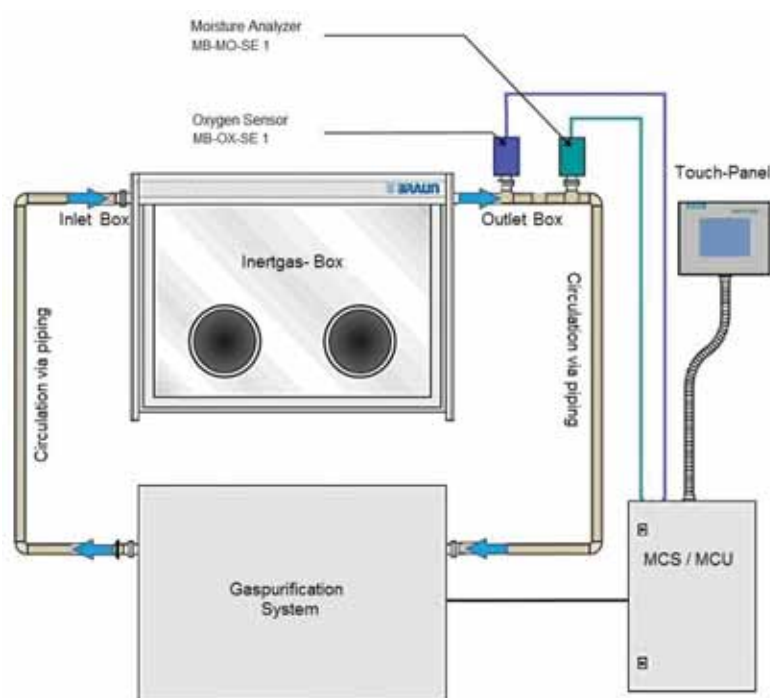

Optional: solvents and other gases can be measured if necessary and evaluated by the controller (See additional equipment section).

2.3.2.2 Automatic box purge (optional)

If a defined limit value of H2O or O2 is exceeded, the box is purged automatically with inert gas (process gas).

Automatic purge + setting of the values and gas quantities: See Chap. 8 Inert gas box

System component inert gas box

2.3.3 Functions for pressure regulation of the box

MBRAUN systems are equipped with a PLC-controlled pressure regulation, which is activated automatically when the inert gas box system is switched on.

2.3.3.1 Definitions and settings

Box pressure	Current pressure that reigns in the inert gas box.
Operating range	Defined pressure range within the operating limits in which the automatically-regulated pressure in the inert gas box may move. Within the operating range, the pressure in the inert gas box can be set by pressing the foot switch. The pressure regulation adheres to this operating range automatically.
Operating limits	The pressure limits of the operating range can be set in a range between the lower operating limit and the upper operating limit. If these limits are exceeded, the pressure is balanced out automatically. Factory settings: Upper operating limit +4 mbar; Lower operating limit -4 mbar. Note: the upper operating limit must be set at least 1 mbar higher than the lower operating limit.
Alarm limits	Outside of the limits of the operating range, alarm limits can be set to protect against under or overpressure in a range of -15 mbar to +15 mbar. If the alarm limits are under run or exceeded, the appropriate gas feed valves or in the circulation for the gas purification close. If > upper alarm limit → pressure discharge – stop gas feed If < lower alarm limit → stop circulation – introduction of gas Factory settings: Upper alarm limit +15 mbar; Lower alarm limit -15 mbar.

Box pressure limits:

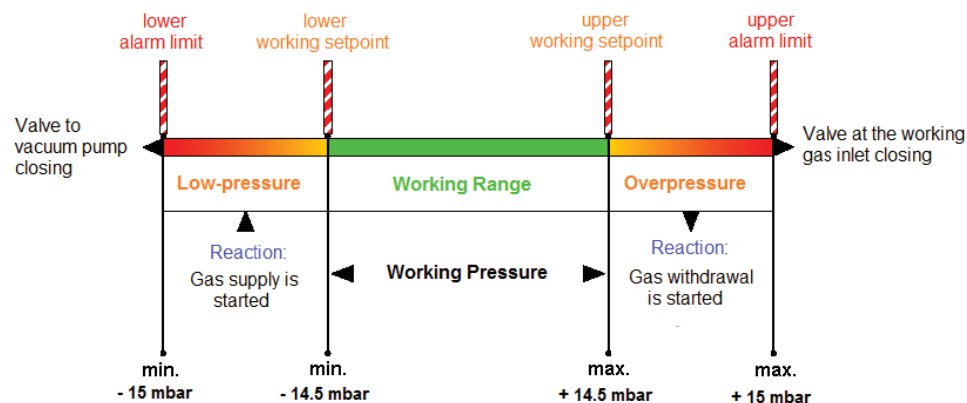

Example: the values displayed can differ from the actual values.

System and system types

2.3.3.2 Automatic pressure regulation

How the pressure regulation works:

If the set pressure values are under run or exceeded, there is automatically a pressure equalisation:

Exceeding of the upper operating limit: Gas is removed automatically until the pressure equals the value of the hysteresis:

Exceeding of the lower operating limit: Gas is fed in automatically until the pressure equals the value of the hysteresis:

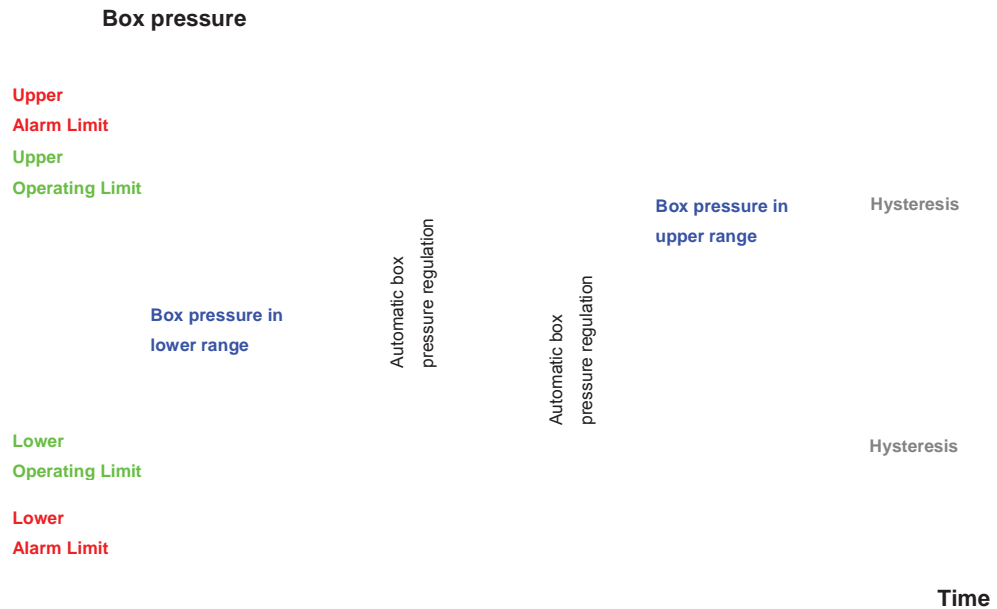

On exceeding/under running of the alarm limits, a warning message is generated on the touch panel (see Chap. 11 Troubleshooting).

Optionally it is possible to set up an opti-acoustic alarm (if an increased safety standard is required).

Setting the values and gas quantities: see Chapter 8, Parameters

2.3.3.3 Pressure regulation via foot switch

Using the foot switch, it is possible to set the box pressure freely at any time within the upper and lower operating limits. For example, when putting hands into the gloves of the box, this allows the box pressure to reach under pressure for a brief time and then to increase slightly thereafter. See Chapter 8, Setting pressure with the foot switch

System component antechamber

2.4 System component antechamber

Antechambers serve the transfer of materials between the box and outside areas. The antechamber atmosphere is - depending on the direction - adapted to the conditions in the box or the ambient air. This prevents a contamination of the box atmosphere.

Definitions

Vacuum antechamber (standard)	The antechamber process for loading is done through evacuation *) and refilling*) – only suitable for vacuum-capable material.
Purge antechamber (option)	The antechamber process for loading is done through purging with inert gas (pressurized from external gas source) - suitable for vacuum-sensitive material.
Loading	Transfer of materials from outside to inside in the box
*) Evacuation	Removal of ambient air from the antechamber with a vacuum pump or (manually-activated) vacuum valve
*) Refilling	Refilling the evacuated antechamber with gas from the box
Antechamber cycle	Includes one cycle of "evacuate and refill" to the defined final vacuum
Unloading	Transfer of materials from the box to the outside

2.4.1 Structure and functions

2.4.1.1 Antechamber types

Function	Type	Diameter / Volume	Function	See
Main antechamber	Round antechamber	(\varnothing 390 mm) standard antechamber	Transfers of process materials	Chap. 8
	Rectangular antechamber	300 x 300 mm (straight model or in L-form) (customer-specific)	Loading from the side or from the front	
	Special antechamber	optional: additional dimensions (customer-specific)		
	T- antechamber	(optional in multi-box systems)	Transfer processes between 2 boxes or between box and outside environment	Chapter 10
Additional antechamber	Mini- antechamber	(\varnothing 150 mm)(optional)	Transfers of smaller materials	Chap. 8

System and system types

Main antechamber and mini-antechamber

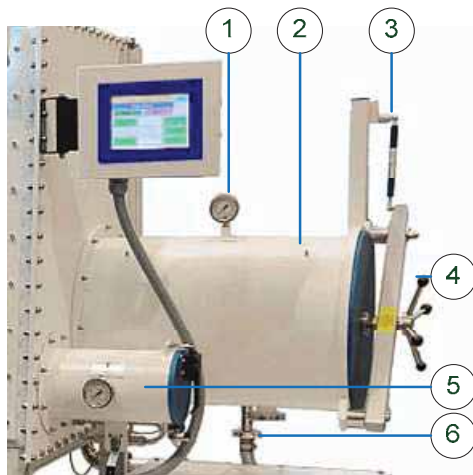

- (1) Manometer (pressure gauge)
- (2) Round antechamber (ø 390 mm)
- (3) Lifting mechanism
- (4) Rotary handle
- (5) Mini-antechamber (ø 150 mm)
- (6) Connection of the vacuum pump

(example picture)

Structure of round antechamber (ø 390 mm)

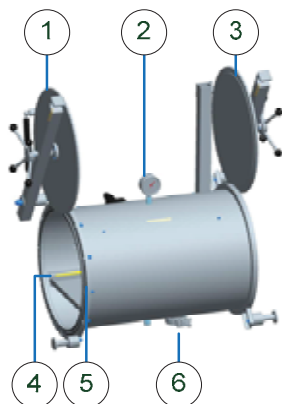

- (1) Inner door
- (2) Manometer (pressure gauge)
- (3) Outer door
- (4) Tray (can be pulled out)
- (5) O-ring – seals
- (6) Connection of the vacuum pump

Structure of mini-antechamber (ø 150 mm) - Option

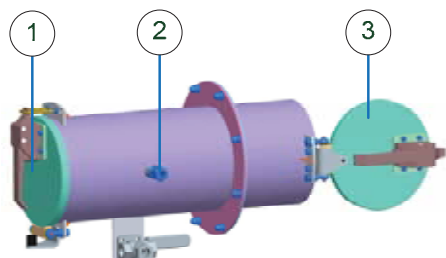

- (1) Outer door with locking lever
- (2) Connection of the gas supply
- (3) Inner door with locking lever

Not shown: Tray (can be pulled out)

System component antechamber

2.4.1.2 Antechamber components

Vacuum pump

Description	Function	See
Standard: oil-sealed rotary disc pump	Generates the vacuum for the evacuation of the antechamber - via vacuum pump of the gas purifier (VPG) - <i>optional: customer-specific vacuum pump (VP)</i>	2.5 and Chap. 15

Pressure monitoring

Description	Function	See
Manometer	Indicates the current pressure in the antechamber.	
<i>For manual evacuation / refilling:</i>	Visual control of the pressure with manual gas feed / removal	Chap. 9
<i>PLC-controlled antechamber</i>	Evaluation of the values measured by the PLC; in addition, display of the pressure on the touch panel	Chap. 9

Gas supply

Designation	Function	See
Gas supply from the box: (standard)	Standard: Inertising of the antechamber with box atmosphere	Chap. 4
External connection	<i>(optional)</i> External refilling with inert gas	Chap. 4
External feed of ambient air	<i>(optional)</i> Refilling of the antechamber with ambient air, valve-controlled	Chap. 4
Pressure reducer	<i>(optional)</i> Regulation of the input pressure with external gas supply	Chap. 4

Operating and control elements

Designation	Function	See
Hand valves	Manual operation of the antechamber	Chap. 9
Electric valves	PLC-controlled operation of the antechamber cycle	Chap. 9

2.4.1.3 Additional equipment – and functions (optional):

Antechamber types	Function	See
T-antechamber (<i>in multi-box systems</i>)	Transfer processes between 2 boxes or between box and outside environment	Chap. 10
Oven antechamber	Heating up of process materials in the vacuum	Chap. 10
Antechamber functions		
Purge antechamber	Transfers of vacuum-sensitive materials Purging of the antechamber with inert gas / ambient air in over pressure	Chap. 10

System and system types

2.4.2 Operation of vacuum antechamber

Standard systems are equipped with a vacuum antechamber.

The atmosphere in the antechamber is prepared depending on the direction of the antechamber process.

Loading the antechamber cycle (PLC-controlled):

After evacuating the antechamber to the final vacuum the refill valve opens and refills the antechamber with gas from the box.

Repeated evacuation and refilling increases the purity of the atmosphere:

Initial state of the antechamber atmosphere (depicted in red) to the target - high degree of purity of the inert gas atmosphere of the box (depicted in green).

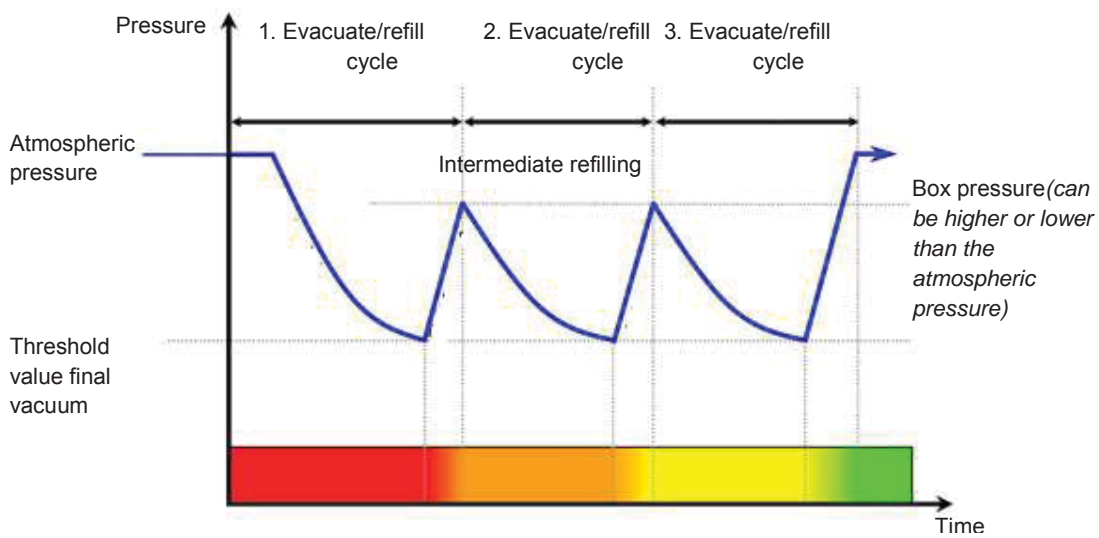

System component antechamber

2.4.3 Principle of the transfer process vacuum antechamber

The atmosphere in the antechamber is prepared depending on the direction of the antechamber process. This process can be controlled manually or by the PLC (see Chap. 8 Antechamber):

Direction	Function	Status of antechamber doors
Loading: Outside → Antechamber → Box	Adaptation of the antechamber atmosphere to the inert box atmosphere and to the box pressure	Outer door is closed – inner door can be open
Unloading: Box → Antechamber → Outside	Protection of the box atmosphere against ambient air a) Antechamber atmosphere = Box atmosphere: direct unloading possible; b) Antechamber atmosphere is filled with ambient air: adapt previously to box atmosphere	Inner door is closed – outer door can be open
<i>Optional:</i>	<i>If the box atmosphere should not get into the ambient air or with large antechambers:</i> Refilling of the antechamber with environmental air	

System and system types

Principle of the transfer process:

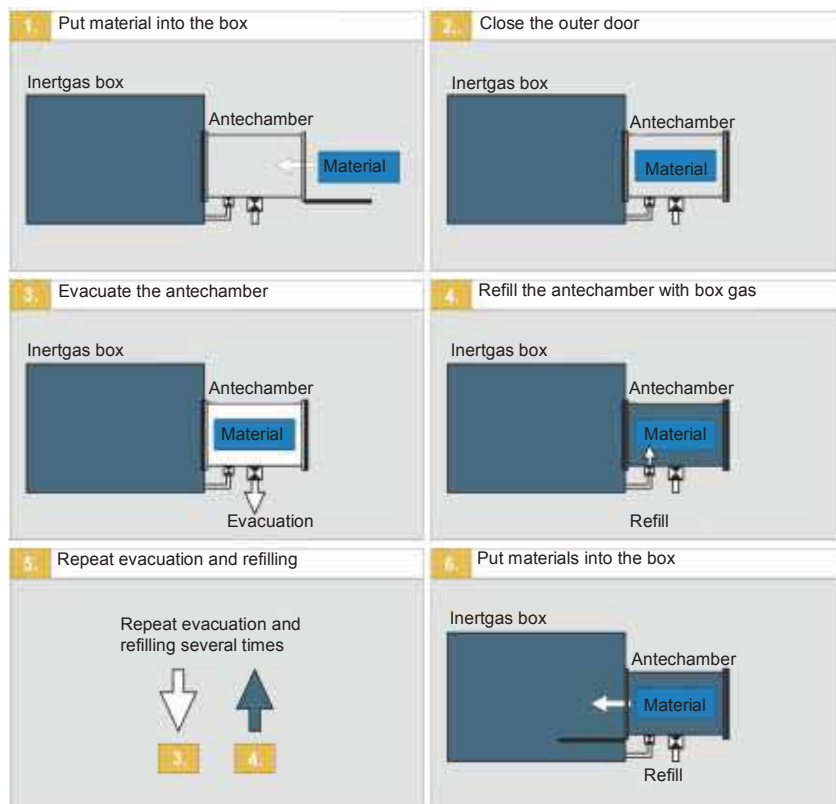

System component vacuum pump

2.5 System component vacuum pump

In standard systems, the components are driven by a common vacuum pump of the gas purifier (VPG). Optionally, additional vacuum pumps can be used (for antechambers, solvent filters, other components).

The vacuum pump is third-party equipment.

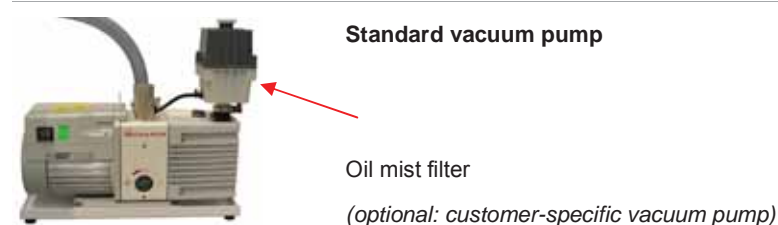

Component	Designation	Function	See
Vacuum pump	Standard: oil-sealed vacuum pump (with oil mist filter) <i>Standard: vacuum pump gas purifier (VPG)</i> <i>optional: customer-specific vacuum pump (VP)</i>	Evacuation processes - Regeneration of the RKM purifier - Box pressure regulation - Antechamber process <i>Optional:</i> Regeneration of the reg. LMF	Supplier documentation
<i>Optional</i>	Purge kit for dry-running pumps	Purging the vacuum pump if contaminated / aggressive gases can travel from the antechamber into the vacuum pump	Chap. 10 A ff
<i>Optional</i>	Connection to in-house exhaust system	If materials that can harm the environment/health are used in the box.	Chap. 4

3.1	Introduction	3-2
3.2	Safety design.....	3-2
3.2.1	<i>Standard system</i>	3-2
3.2.2	<i>Process materials: Classification and assessment of substances.....</i>	3-3
3.2.3	<i>Hazard classes.....</i>	3-5
3.3	Proper use	3-9
3.3.1	<i>Product protection</i>	3-9
3.3.2	<i>Personal protection</i>	3-10
3.4	Misuse.....	3-11
3.5	Potential risks (residual risks)	3-12
3.5.1	<i>Dangers when handling gases</i>	3-12
3.5.2	<i>Mechanical dangers</i>	3-14
3.5.3	<i>Danger in case of error.....</i>	3-14
3.5.4	<i>Electrical hazards</i>	3-15
3.6	User-specific process materials	3-16
3.6.1	<i>Risk due to solvents, chemicals and gases.....</i>	3-16
3.7	Overview: Safety + Operation of the system.....	3-17

Introduction

3 Safety

3.1 Introduction

This safety chapter contains basic instructions about the safety and protection design for the safe handling of the **MBRAUN** inert gas system, as well as notes about the main risks (residual risks) that can occur with the use of an inert gas system.

The specific safety instructions for the operation of the components are at the beginning of each chapter (initial safety instructions) as well as in the individual action steps (integrated safety instructions) according to EN 82079-1 and ANSI 535.6).

The safety instructions listed in the manual complete the safety guidelines for the workplace and do not invalidate these.

3.2 Safety design

3.2.1 Standard system

Structure, function and control of **MBRAUN** inert gas systems secure an inert gas atmosphere in a quality of

- O₂ content < 1ppm
- H₂O content < 1ppm
- Leak rate < 0.05 Vol % / h (according to DIN ISO 10648-2)

The safety design for **MBRAUN** standard inert gas systems includes:

Product protection

Standard inert gas systems are designed primarily for product protection of the materials handled inside the box against oxygen and moisture.

Additional equipment for product protection If high-quality materials can be destroyed in case of accidental contact with ambient air, **MBRAUN** recommends system modifications for protection against malfunctions.

Additional equipment personal protection

Specific system modifications and additional safety equipment are always required for the redundant securing against (multiple) malfunctions in case of the use of gases and process materials that are toxic or harmful to health if they

- are flammable or explosive in contact with ambient air
- cause dangerous situations
- contain (micro) biological, pharmaceutical and nuclear applications

See below "Proper use" and "Misuse".

3.2.2 Process materials: Classification and assessment of substances

The operator of the system is obligated to undertake a classification and assessment of the substances handled inside the inert gas box. **MBRAUN** recommends conducting a workplace hazard analysis. The operator is obligated according to the occupational protection law (ArbSchG) and also according to the accident prevention regulation "Principles of Prevention" (BGV A1 and GUV-V A1).

The hazard analysis indicates whether the substances used in an inert gas box system should be handled in over or under pressure, or whether additional safety measures are required during operation in under pressure.

The classification and assessment is necessary in order to select a system suitable for the application with the necessary system modifications and safety equipment.

The assessment and classification can be conducted with known substances taking into account the H and P statements (R and S statements) or OEL level.

DANGER

Unknown risks can arise from unknown bonding of process materials.

Depending on the degree of hazard, there may be consequences for health and the environment.

- ▶ In case of unknown bonding, these must be assessed as well as possible by the customer using similar substances and substance classes.

WARNING

If process materials are used in large quantities, with high particle content or contact time, additional risks can arise.

There can be personal injury and/or material damage.

In case of exceeding of the following factors: quantity : > 1 kg / form: very dusty / contact time: > 15 min/day





- ▶ Please contact **MBRAUN** Service.



Depending on the hazard class, various system modifications and safety equipment are necessary; these are explained in more detail in Section 3.2.3.

Safety design

The following table shows how the substances used can be divided roughly into hazard classes using exposure limits and H and P-signs (R and S-signs). The quantity used, the form and the contact time were not taken into account here.

Overview of hazard classes and acceptable limits of exposure

Pictogram	Class	Acceptable limits of exposure: $\mu\text{g}/\text{m}^3$ dust ppm vapor	Typical R-statements Typical H-statements
	Class 0 General ventilation	1,000 – 10,000 $\mu\text{g}/\text{m}^3$ 50 – 500 ppm	R36, R38 H319, H315
	Class I Low and "normal" hazard	100 – 1,000 $\mu\text{g}/\text{m}^3$ 5 - 50 ppm	R20, R21, R22 (not in combination with R48) H332, H312, H302 (not in combination with H317)
	Class II Increased hazard	10 – 100 $\mu\text{g}/\text{m}^3$ 0.5 – 5 ppm	R23, R24, R25 (not in combination with R48) R34 R35, R37, R41, R43 R48 with one or several R20, R21, R22 H331, H311, H301 (not in combination with H317) H314, H335, H318, H317 H372 with one or several H332, H312, H302
	Class III Activities with carcinogenic, mutagenic and fertility-compromising hazardous materials	1.0 - 10 $\mu\text{g}/\text{m}^3$ 0.05 – 0.5 ppm	R26, R27R28 Carc cat 3 R40, Muta Cat 3 R40 R48 with one or several R23, R24, R25 R60, R61, R62, R63 H330, H310, H300 H351 H372 with one or several H314, H335, H318, H317 H360, H361

Pictogram	Class	Acceptable limits of exposure: µg/m ³ dust ppm vapor	Typical R-statements Typical H-statements
	Class IV Special personal protection for extremely hazardous substances	0.01 – 1.0 µg/ m ³ 0.005 – 0.05 ppm	R42, R45, R46, R49 H334, H350, H340
	Class EX Activities with hazardous materials flammable in air		R16, R17, R18 H251, H224, H225, H226

Source: assembled according to:

Nigel Hirst, Mike Brocklebank and Martyn Ryder (2002): *Containment System. A Design*. Published by Gulf Professional Publishing. ISBN 0 7506 7612 4. Transferred to Digital Printing 2008.

3.2.3 Hazard classes

Distinguished are the hazard classes 0 - IV as well as EX. The hazard class 0 regards only the product protection; personal protection is not considered in initial case of error. The hazard classes I – IV include personal protection. In initial case of error, the user must be protected; the materials used are the second priority. The hazard class EX treats personal protection for the use of gases (or vapor) mixtures as well as fixed bonds that burn in air or ignite themselves.

! An optimal product and or personal protection can only be guaranteed with the use of the correct system modifications and safety equipment.

3.2.3.1 Hazard class 0

Class 0 includes the product protection. The inert gas box is operated in over pressure in order to ensure that no oxygen or moisture penetrates the inert gas box.

Here generally system modifications and safety equipment are only necessary if the materials handled are very valuable and in case of error should not come into contact with air.

Safety design

3.2.3.2 Hazard class I

Class I includes personal protection for low and "normal" hazards.

With this class, a choice can be made between an over pressure and under pressure inert gas box. The following system modification is recommended:

- Alarm in case of pressure drop or increase: in case of a spontaneous pressure drop or increase (leak), an acoustic alarm is emitted.

3.2.3.3 Hazard class II

Class II includes personal protection with "increased" hazard. In order to guarantee safety, the inert gas box must be operated in under pressure so that in case of a leak, the users are protected against the substances used. The following system modifications and safety equipment are required:

- Alarm in case of pressure increase In case of a spontaneous increase (leak), an acoustic alarm is emitted
- Securing of pressure operation Secured pressure operation of the inert gas box between -3 and -10 mbar. Also allows the safe operation of the inert gas box if all gloveport feedthroughs are sealed with an interior or exterior sealing door. Per antechamber connected (or antechamber oven), a door lock is required.
- Securing against glove tearing In case of a glove tear, prevents a streaming out of the enclosed gas atmosphere and the escape of dust due to an inward airstream with streaming speed between 0.5 and 0.7 m/s.
- Secure unloading Automatic antechamber cycle during unloading: the antechamber is evacuated automatically and refilled before it can be opened to the outside. Always required if toxic or flammable substances are processed inside the inert gas box. A cover lock per connected antechamber or antechamber oven is required.
- Combined exhaust The exhaust from the vacuum pump and quick-purge (if present) is combined in a connection for the connection to a customer-side exhaust. Including safe differential pressure monitoring of the customer-side exhaust

3.2.3.4 Hazard class III

Class III includes personal protection for activities with carcinogenic, mutagenic and fertility-compromising hazardous materials. In order to guarantee sufficient protection, the inert gas box must be operated in under pressure so that in case of a leak, the users are protected against the substances used. The following system modifications and safety equipment are required:

- Alarm in case of pressure increase In case of a spontaneous increase (leak), an acoustic alarm is emitted
- Securing of pressure operation Secured pressure operation of the inert gas box between -3 and -10 mbar. Also allows the safe operation of the inert gas box if all gloveport feedthroughs are sealed with an interior or exterior sealing door. A door lock is required per antechamber connected or antechamber oven.
- Securing against glove tearing In case of a glove tear, prevents a streaming out of the enclosed gas atmosphere and the escape of dust due to an inward airstream with streaming speed between 0.5 and 0.7 m/s.
- Secure unloading Automatic antechamber cycle during unloading: the antechamber is evacuated automatically and refilled before it can be opened to the outside. Always required if toxic or flammable substances are processed inside the inert gas box. A cover lock per connected antechamber or antechamber oven (1500284) is required.
- Combined exhaust The exhaust from the vacuum pump and quick-purge (if present) is combined in a connection for the connection to a customer-side exhaust. Including safe differential pressure monitoring of the customer-side exhaust.
- Fail-safe PLC controller Replacement of the standard PLC with a fail-safe PLC with secure digital inputs and outputs and secure analog inputs. Including risk analysis for the complete system in cooperation with the principal.

3.2.3.5 Hazard class IV

Special personal protection for extremely hazardous substances.

Customer-specific solution Including risk analysis for the complete system in cooperation with the principal.

! Please contact **MBRAUN** Service.

3.2.3.6 Hazard class EX (inside)

The class EX includes personal protection for activities with hazardous materials that burn in air. In order to guarantee this, it is recommended that you operate the inert gas box in over pressure so that in case of a leak, no oxygen gets into the box. The following safety components are required:

(MB no. only for new system)

- Alarm in case of pressure increase In case of a spontaneous increase (leak), an acoustic alarm is emitted
- Secure unloading (MB no. 1507303) Automatic antechamber cycle during unloading: the antechamber is evacuated automatically and refilled before it can be opened to the outside. Always required if toxic or flammable substances are

Safety design

processed inside the inert gas box. A cover lock per connected antechamber or antechamber oven (1500284) is required.

- Combined exhaust (MB no. 1507304) The exhaust from the vacuum pump and quick-purge (if present) is combined in a connection for the connection to a customer-side exhaust. Including safe differential pressure monitoring of the customer-side exhaust
- Fail-safe PLC controller (MB no. 1507305)
Replacement of the standard PLC 313C with a fail-safe PLC 315F with secure digital inputs and outputs and secure analog inputs. Including risk analysis for the complete system in cooperation with the principal
- Safe oxygen measurement (MB no. 1507306) Secured EX zone shift of the inert gas box atmosphere if gases that burn in air can occur in concentrations inside the inert gas box, for which the gas mixture would burn in air, there is a secure zone shift inside the box through securing of operation at <2% oxygen even in case of error. Including oxygen measurement with self-check and secure quick-purge in case of error. Including upgrade of all pressure sensors to "EX model". Including upgrade of the gloveport feedthrough to "conductive".

3.3 Proper use

3.3.1 Product protection

An **MBRAUN** inert gas box is - together with a gas purifier - used in order to generate and maintain an inert gas atmosphere in a hermetically-sealed workspace.

The proper use is use for product protection. Moist and/or oxygen-sensitive materials can be handled and processed within this atmosphere. The processing is done manually using gloves or automated using special handling systems.

By default, operation with nitrogen, argon or helium as inert gas or as mixture is prescribed. Other gases or gas mixtures of non-reactive gases are possible, however can in certain cases require a modification of the system or additional protective measures.

MBRAUN inert gas systems are intended exclusively for professional use.

- Only use the system as described in the operating manual!
- Only personnel may be used who met the requirements defined in this operating manual!
- **MBRAUN** standard systems are not set up by the manufacturer for applications that require secured personal protection.

System modifications can also be required with use of hazard class 0 materials:

- For use of high-quality materials that can be destroyed if they reach the ambient air in case of system malfunctions.

Proper use

3.3.2 Personal protection

For applications that require secured personal protection in addition to product protection, special system modifications and safety equipment are required; these are not included in the scope of delivery of the standard system.

If one or more of the following points apply, personal protection is required:

- Substances that can cause dangerous situations if they reach the ambient air in case of system malfunction.
- Substances which, if they reach ambient air in case of system malfunctions, are easily flammable or explosive.
- Pharmaceutical and nuclear applications.
- Extremely toxic or harmful materials

MBRAUN creates a concept for secured personal protection in consultation with the customer if substances or gases of hazard classes II, III, IV or EX are used in the system.

! Please contact **MBRAUN** Service if your application falls into one of the categories mentioned above or if you have questions about this.

3.4 Misuse

DANGER

Risk to life, health and the environment!

All applications that require secured personal protection are not permitted for standard systems:

- Substances that can cause dangerous situations if they reach the ambient air in case of system malfunction.
- Substances which, if they reach ambient air in case of system malfunctions, are easily flammable or explosive.
- (Micro) biological, pharmaceutical and nuclear applications
- Extremely toxic or harmful materials
- Operation with reactive or toxic gases or gas mixtures as intentional box atmosphere (e.g. gas mixture of inert gas and hydrogen or carbon dioxide)

For these applications, special system modifications and safety equipment are required, which are not included in the standard scope of delivery (Class I-IV).

- The system may not be rebuilt or changed without authorisation!
- The bridging of end switches, valves and other control components is forbidden!
- The system may not be used outside of the technical data and operating limits specified in this operating manual!

DANGER

Risk of personal injury!

The system may not be operated if:

- There is visible damage
- It is not working in the framework of the specifications
- It was not stored properly
- If it was subjected to extreme, improper transport conditions

If one of these points is relevant, then

- ▶ Take the system out of operation!
- ▶ Secure it against unauthorised or unintentional commissioning!
- ▶ Make contact with the **MBRAUN** Service Department!

Potential risks (residual risks)

3.5 Potential risks (residual risks)

3.5.1 Dangers when handling gases

In case of error or operating error, there can be dangers in the handling of inert gases.

3.5.1.1 Risk of suffocation

DANGER

With a high concentration of inert gases, there is a risk of suffocation! Below an oxygen concentration of < 18%, a loss of consciousness, irreversible damage and death may occur!

- ▶ Never put your head or entire body in the interior space of an inert gas box or antechamber.
- ▶ Do not breathe in gases!
- ▶ Always ensure sufficient ventilation of the work area / workspace
- ▶ Before performing maintenance work inside the inert gas box or the antechamber, the inert gas atmosphere in the box must be replaced with room air. *Follow the instructions in the chapter "Inspection and Maintenance".*

If the specifications for the set-up of the system cannot be adhered to:

- ▶ Use a wearable personal oxygen warning device that warns you if there is a critical lack of oxygen concentration in the ambient air.

3.5.1.2 Risk of combustion and explosion

For the handling of process materials in the box, please follow the instructions above for "Proper use".

DANGER

Risk to life when handling combustible or explosive gases!

There is a risk of explosion for gases whose self-combustion temperature $\leq 60^{\circ}\text{C}$ if they come into contact with oxygen (e.g. with ambient air!) into contact with high temperatures of the devices used in the workspace!

This is especially relevant with use of solvents or hydrogen concentration $\geq 4\%$!

- ▶ It must absolutely be ensured that the concentration of a hydrogen/oxygen mixture within an inert gas box never exceeds the specified safety limits !
- ▶ The user is responsible for strict adherence to the safety limits!
- ▶ With use of combustible or explosive gases, additional safety equipment is required that is not a component of the **MBRAUN** standard inert gas box system.
- ▶ If necessary, contact the **MBRAUN** Service Department.

For use of hydrogen mixtures, distinguish:

Use of hydrogen mixtures in the box	DANGER The critical limit value of 4% must be under run significantly - additional safety equipment is required!
Use of hydrogen mixtures for the regeneration of reactors RKM	Limit value 3-10%
<p>Use of hydrogen mixtures as regeneration gas for reactors (RKM)</p> <p>To regenerate the reactors (RKM), a hydrogen mixture with a concentration of 3-10% H₂ in N₂ or Ar is used (<i>see Chapter 4, Installation</i>).</p> <p>This gas mixture serves as process gas for the reduction of the Cu catalyst.</p> <p>This process takes place in a closed system and is secured by MBRAUN in defined processes (<i>see chapter Gas purifier, regenerating</i>).</p>	

CAUTION

Exceeding the hydrogen concentration $>10\%$ causes overheating of the reactor during regeneration!

- ▶ Be sure to adhere to the specified hydrogen concentration of 3-10%!

Potential risks (residual risks)

3.5.2 Mechanical dangers

3.5.2.1 Risk of crushing on moving parts and rotating devices in the box

CAUTION

Risk of injury to hands and arms due to crushing, bending, cutting and shearing movements on moving parts! Risk of injury due to catching in rotating equipment in the box!

- ▶ Keep hands and arms out of the range of moving parts!
- ▶ With the use of (fast) moving parts and equipment in the box, protection against reaching in (monitoring by light curtains + STOP function) may be required.

3.5.3 Danger in case of error

3.5.3.1 Risk of injury due to ejected materials

WARNING

Personal injury in case of error

Risk of injury due to ejection of material with use of mechanical, pneumatic and vacuum-technical components!

- ▶ Always adhere to maintenance cycles
- ▶ Repair work on components may only be performed by authorised personnel
- ▶ Keep hands and arms out of the danger area!

3.5.3.2 Risk of injury in case of system damage and operating error

WARNING

Risk of injury due to damage to the system and operating error

- ▶ In case of damage to and safety defects on the system: take the system out of operation immediately and inform the service personnel!
- ▶ Do not open the system during operation or in case of power failures!
- ▶ Safety doors, side walls, separating walls, panes and doors may not - except in case of service - be removed.
- ▶ Follow the operating manual
- ▶ In case of doubt, contact **MBRAUN** Service.

3.5.4 Electrical hazards

DANGER

Risk of personal injury due to electrical voltage such as uncontrolled muscle reactions, crippling, burns or death.

- ▶ In case of electrical shock, inform the emergency physician immediately
- ▶ Only a trained electrician may open the control cabinet.
- ▶ Switch off the main switch before opening the control cabinet.

Components such as condensers and contacts are still energised even after they are switched off!

- ▶ All work on the control cabinet and the electrical system may only performed by a trained electrician.

Before working on the electrical system and the electronics:

- ▶ Remove the mains plug from the outlet or de-energise the mains connection!

The system may not be operated with an open control cabinet door!

DANGER

Risk of personal injury and property damage due to electrical voltage and impermissible currents!

- ▶ No provisional fuses and/or short-circuit fuses may be used!
- ▶ Do not change or replace current-carrying lines!

The mains connection must be made according to local guidelines. The system must always be earthed, see Chap. 13 Wiring diagrams.

3.5.4.1 Electrostatic discharge

DANGER

Risk of personal injury and property damage due to electrostatic discharge!

When working with plastic parts, hoses, tubes, cables and the system itself, there can be electrostatic charges and unexpected discharges. This can ignite solvents or process chemicals if these are not subjected to the inert gas atmosphere.

Earth the entire system sufficiently → see *Chap. 13 Wiring diagrams*

User-specific process materials

3.6 User-specific process materials

Solvents, chemicals and process gases are not supplied by **MBRAUN**. All required substances are provided and used by the user.

The safe use of these is the responsibility of the customer. Please follow the instructions above for "Proper use" (product protection and personal protection) as well as for hazard analysis.

3.6.1 Risk due to solvents, chemicals and gases

DANGER

Risk of injury and damage!

Gases and chemical can be flammable, explosive and/or toxic!

Chemicals released can react with one another and cause unexpected and/or unknown risks.

Solvents can destroy seals of the inert gas box or other components (e.g. cooling) or the material of the gloves. Solvent vapors are absorbed by the reactor material and can reduce its capacity to absorb water vapor.

Please note the following:

- ▶ The user is responsible for the proper handling of gases and chemicals.
- ▶ Classify the hazard classes of the process materials used.
- ▶ All guidelines such as EU directive 98/24/EC, Control of Substance Hazardous to Health (COSHH) must be adhered to.
- ▶ Heed all applicable safety regulations and safety data sheets (material data sheets) of the manufacturer.
- ▶ Always mark chemical containers and supply lines with the appropriate labels and warning labels.
- ▶ Wear personal protective equipment (PPE) according to the gases, processes and process materials used (e.g. breathing protection full mask with suitable filter, protective gloves and eye protection).
- ▶ Ensure sufficient ventilation and solvent exhaust!
- ▶ Do not breathe in gases!
- ▶ Keep away sources of ignition! Do not smoke!

If regular work with organic solvents will be done in the inert gas box, the gas purifier should be equipped with a solvent filter and a solvent sensor.

3.7 Overview: Safety and Operation of the system

The operating and operating-relevant safety instructions are in the respective chapters.

Preceding safety instructions introduce the operation of the function or components in question

Integrated safety instructions are placed before a sequence of operations or an action step

Preceding safety instructions

Safety	Description	Product protection	Personal protection	Environmental protection	Chapter
Installation & organisational preparation	Damage to the system and additional risks due to improper installation	x			4.2.1
	Preventable risks due to lacking safety markings on the system	x	x		4.2.1
	Health and environmental hazards in case of incorrect handling of gases → Trained professionals		x		4.2.1
	Health hazards due to (contaminated) exhaust gases → Connection of in-house exhaust system		x		4.2.1
	Hazards due to system expansions, customer-specific processes, process materials, gases → Measures in advance hazard/risk analysis, safety equipment and functions, marking of the system, discharge of exhaust, waste		x	x	4.2.2
	→ Measures for safe operation: SOP, behavior in case of emergency, training	x	x	x	4.2.2
	Operating the system	Basic principles of operation			
Operating Manual		x	x		6.2.1
Personnel		x	x	x	6.2.2
Responsibilities for operation of the system		x	x		6.2.2.1
Protective equipment / additional equipment			x		6.2.2.2
Environment				x	6.2.3
Damage to the system			x		6.10.1
Disposal			x	x	6.11.1
Gas purifier	- Damage to the gas purifier due to ambient air / or	x			7.2.1
	- Compromising of the gas purifier performance due to ambient air				

 Overview: Safety and Operation of the system

Safety	Description	Product protection	Personal protection	Environmental protection	Chapter
	Regeneration - risks with use of H ₂ mixtures > 10%	x			7.2.2
	Risks with use of solvents - solvent filters (LMF) - parallel operation / exhaust gases		x		7.2.3
	Risks with use of solvents - solvent filters (LMF) - consequences in case of operation with saturated LMF	x	x		7.2.3
Inertgas box					
	Damage to the reactors during circulation operation with ambient air	x			8.2.1
	Damage to the sensors during circulation operation with ambient air	x	x		8.2.1
	Risk of suffocation in case of operating error when opening an inertised box		x		8.2.2
	Risk of suffocation in case of error with permanently-activated automatic box purge		x		8.2.2
	Damage due to extreme pressure changes (glove tear) - in case of harmless process materials	x			8.2.2.1
	Mech. damage due to extreme pressure change with use of dangerous process materials		x		8.2.2.2 9.2.1.1
	Material damage to gloves	x			8.3.5

Safety	Description	Product protection	Personal protection	Environmental protection	Chapter
Antechambers	Risks due to operating errors during the antechamber processes depending on processes/process materials used	x	x		9.2
	Transport containers: contamination of the box atmosphere due to enclosed ambient air	x			9.2
	Transport container, not vacuum-suitable: risk of explosion	x	x		9.2
	Antechamber doors + antechamber atmosphere:				9.2.1
	Loading: disturbance of the box atmosphere by oxygen + moisture: status of the antechamber atmosphere + heed doors! Unloading: compromises due to inert gases + nitrogen oxide After completing antechamber processes: compromises of box atmosphere - environment	x			9.2.1.1
		x	x		9.2.1.2
					9.2.1.3
		x	x		
Maintenance					
Maintenance cycles	Risk of health and environmental damage due to material damage in case of non-adherence to maintenance cycles		x	x	12.2
Qualification of personnel	Risks to people and the environment due to improperly-performed inspection and maintenance work.		x	x	12.2
	Risk of suffocation or health hazards when opening boxes under inert gas atmosphere!		x		12.2
Electrical	Risk to people due to electrical shock in case of improper handling of electrical components!		x		12.2
Process materials	Health and environmental risks due to gases, processes and process materials used!		x	x	12.2

 Overview: Safety and Operation of the system

Safety	Description	Product protection	Personal protection	Environmental protection	Chapter
Sensors, particle filter	<p>Personal injury and environmental damage due to contamination through hazardous processes/process materials!</p> <p>Sensors and particle filters are constantly subjected to the gas flow in the box/the gas purifier. When using hazardous materials in the inert gas box, people and the environment are at risk!</p>		x	x	12.2
Gloves	<p>Ambient air penetrates the box due to damaged gloves and disturbs the inert gas atmosphere. The box atmosphere can escape and cause personal injuries.</p> <p>Depending on the gases and processes/process materials used, there can be material damage and/or personal injury (risk of suffocation!).</p>	x	x		12.5.2
Sensors	<p>The sensor is constantly subjected to the gas flow. With the use of hazardous materials in the inert gas box, there is the risk of a contamination.</p> <p>The exchange process described here is not suitable for the use of hazardous materials.</p>		x		12.5.4
	<p>Personal injuries due to chemical burns to the skin and the eyes with use of phosphoric acid!</p>		x		12.5.4.2
LMF	<p>Solvent filter: risk of personal injury and material and environmental damage due to remaining solvents/vapors during changing of the filter medium!</p>		x	x	12.5.9

4.1	Introduction	4-2
4.2	Safety during preparation and installation.....	4-3
4.2.1	Standard system	4-3
4.2.2	Specific: use of hazardous processes/process materials.....	4-4
4.3	On-site conditions.....	4-5
4.3.1	Installation site	4-5
4.4	Transport	4-7
4.4.1	Regard transport markings.....	4-7
4.4.2	Transport in wooden crates / on pallets.....	4-8
4.4.3	Lift transport goods from the pallet, bring them to the installation location.....	4-9
4.5	Connection preparations - overview.....	4-13
4.6	Gases and accessories.....	4-14
4.6.1	Gas types	4-14
4.6.2	Operating gas.....	4-14
4.6.3	Purge gas (manual purge).....	4-15
4.6.4	Regeneration gas	4-15
4.7	Cooling water and accessories.....	4-19
4.7.1	Water cooling	4-19
4.8	Vacuum pumps and accessories.....	4-20
4.9	Connecting the system.....	4-21
4.9.1	System workstation Labmaster SP/DP.....	4-21
4.9.2	System with gas purification platform MB20/MB200 G with MOD-Box	4-24
4.9.3	Connecting the operating gas	4-25
4.9.4	Connecting the regeneration gas	4-26
4.9.5	Connecting disposal line for regeneration gas	4-26
4.9.6	Disposal line for vacuum pump exhaust.....	4-27
4.9.7	Connecting the cooling water	4-27
4.9.8	Installing sensors (optional).....	4-27
4.9.9	Mains supply	4-29
4.9.10	Potential equalisation	4-29
4.10	Installing additional components.....	4-30
4.11	Acceptance.....	4-30

4 Preparation and Installation

4.1 Introduction

This chapter is intended for the operator and personnel responsible for the operation and service of the **MBRAUN** system.

The delivered **MBRAUN** system – including this operating manual – offers the technical and process-specific conditions for the safe operation of an inert gas system.

Prerequisite for the safety of the system is the proper preparation of the conditions on-site. The operator is responsible for making sure that the organisational prerequisites for the safe handling of the system are provided.

Follow especially the details in the safety and operator duties chapter and the on-site conditions (*Chap. 4.2 and 4.4*).

Preparing the on-site conditions

- Ambient conditions
- Floor conditions, carrying capacity
- Connections: mains and gas supply, coolant connections

Check hazard potential

- ▶ Check the process materials and processes used for their hazard potential (including their mutual reactions and final products).
- ▶ Follow the instructions in the safety chapter (Chap. 3).
- ▶ If necessary, set up additional equipment and functions
- ▶ If necessary, create a standard flow plan / standard operating procedure (SOP) for the specific conditions on-site:

Standard flow plan - standard operating procedure (SOP)

- ▶ Specify the procedures according to your specific hazard and risk analysis:
 - Regard the applicable data sheets and standards
 - Agree on the procedures with your fire safety officer/radiation safety officer
 - Always mark chemical containers and supply lines with the appropriate labels and warning labels.
 - Use vacuum-resistant closed containers
 - Use personal protective equipment (PPE): keep breathing protection full mask (with suitable filter), protective gloves and eye protection at the ready

Training of the personnel / defining responsibilities

Train the personnel so that they can operate the system properly.

(See also Chap. 6.2).

Installation and commissioning

MBRAUN recommends having the installation and commissioning performed by **MBRAUN** trained personnel.

If you perform the installation and initial commissioning yourself:

- ▶ Follow the details for the installation and the instructions for commissioning in *Chapter 6*.

4.2 Safety during preparation and installation

NOTICE

Improper preparation of the installation of the system can cause damage to the system and additional risks.

- ▶ Follow the instructions for installation and commissioning (See *Chap. 4 and 6*).
 - ▶ Installation and dismantling should only be performed by qualified trained personnel.
-

4.2.1 Standard system

The system has safety markings that should protect the operator against foreseeable dangers.



WARNING

Missing safety marking on the system causes preventable dangers!

- ▶ Always keep all safety markings on the system visible and legible
-

The accessories described in this chapter (gases, pressure regulators, etc.) are required for the connection of the system, but are not a component of the scope of delivery.



WARNING

Health and environmental hazards in case of incorrect handling of gases!

- ▶ The system must only be connected by trained personnel
 - ▶ Attach a cut-off valve to the gas supply line
-

Safety during preparation and installation

The safe discharge of exhaust is the responsibility of the customer. **MBRAUN** assumes no liability for contamination of the surrounding atmosphere and any resulting health and environmental damage.

**WARNING**

Health and environmental hazards due to (contaminated) exhaust gas!

With the use of toxic or radioactive materials:

- ▶ Do not discharge gases into the environment.
- ▶ Connect the exhaust from the system to an in-house exhaust system.

4.2.2 Specific: use of hazardous processes/process materials

Additional system equipment**WARNING**

System expansions and/or customer-specific processes/process materials/gases can cause specific hazards to health and the environment, depending on the degree of hazard of the materials used.

With the use of processes/process materials that present a hazard to health or the environment:

- ▶ Conduct a hazard analysis and if necessary a risk analysis
- ▶ If necessary, install additional safety equipment and functions
- ▶ Mark the system/system components with warning signs
- ▶ Connect the exhaust to an in-house exhaust system
- ▶ Ensure waste disposal according to valid national guidelines
- ▶ In case of questions, please contact **MBRAUN** Service

Preparation for the operation of a system with hazardous processes/process materials**WARNING**

Depending on the type and degree of hazard of the processes/process materials used, the operator of a system is subjected to a specific risk.

- ▶ Conduct a hazard analysis and if necessary a risk analysis
- ▶ Take measures for the safe handling of the processes/process materials according to your hazard or risk analysis
- ▶ Specify measures for behaviour in case of emergency (fire, escape or large quantities of inert gas, electrical failure)
- ▶ Summarize the measures if necessary in a standard operating procedure (SOP)/standard flow plan and hang it up where the operator can see it
- ▶ Train the operating personnel for behaviour in case of emergency

4.3 On-site conditions

4.3.1 Installation site

The location for **MBRAUN** systems must be checked for the following on-site conditions.

Prerequisites:

Room	Room temperature: +15°C and +30°C dry room climate Good room ventilation
Area	Floor level and even, no angles Carrying capacity: approx. 500 kg/m ²
Distance	Minimum distance to walls and objects 600 mm sufficient freedom to move in the work areas, e.g. glove areas, antechamber area and service areas
Room volume	The room volume must be significantly larger than the volume of the housing of the inert gas box.

If the system is a component of other systems, then the regulations and documentation for these systems with respect to the location must also be taken into consideration. In case of questions, please contact **MBRAUN** Service.

Securing of the installation location

For the case that the on-site conditions*) cannot be adhered to or the securing of specific devices in case of error is required, **MBRAUN** recommends safety measures such as, for example:

Exhaust system	Monitoring of the function of the exhaust system and warning in case of disturbances/failure of the exhaust system
Oxygen content in the room air	Monitoring of the room air + O ₂ warning device: alarm in case of under running of a minimum oxygen concentration
Redundant gas supply shut-off	Safety kit for the redundant gas shut-off of the gas supply line (not included in standard scope of delivery; please contact MBRAUN Service).
Keep personal protective equipment (PPE) / oxygen masks ready	In front of the work room In the work room Personal O ₂ warning device
Supervision of the room and mark room with signs	In case of alarm, only enter the room with an oxygen mask

On-site conditions

In case of inert gas supply from compressed gas bottles:

*) If the customer draws his inert gas supply from a compressed gas bottle (200 bar, 50 l = 10 Nm³), there is a risk only if the free room volume is smaller than 100 m³.

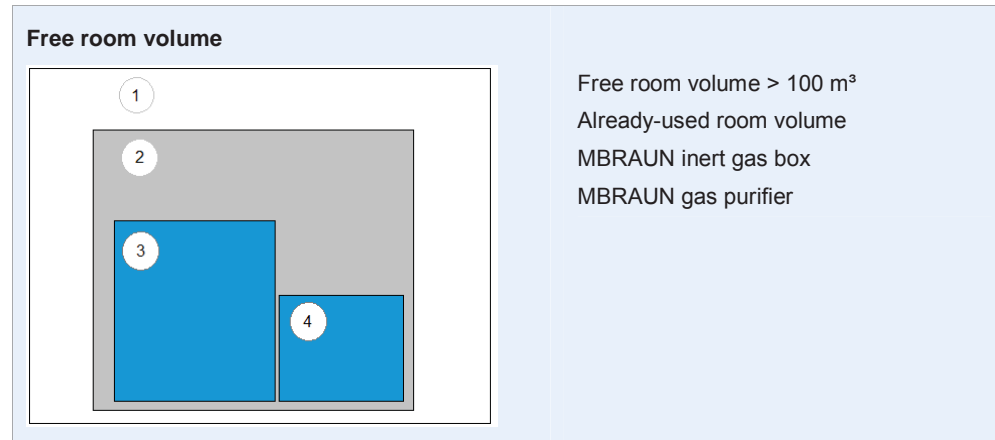

With installation of the system components in different locations:

If the gas purifier and inert gas box are installed in different locations, the instruction applies for both components of the system.

In case of questions, please contact [MBRAUN Service](#).

Danger in case of failure to follow the on-site conditions



DANGER

Risk of suffocation in case of failure to follow the on-site conditions!

Standard systems: when purging with operating gas or when opening inert gas-filled antechambers, inert gas escapes. This can cause a risk of suffocation!

Adhere to on-site conditions

- ▶ The remaining room volume must be significantly larger than the interior volume of the inert gas box.
- ▶ Set up the system in an area with good ventilation
- ▶ If possible, discharge exhaust via an exhaust gas discharge system!

If you cannot fulfil one or more of these conditions or if you would like advice about your specific on-site conditions:

- ▶ Please contact [MBRAUN Service](#).

4.4 Transport

Before delivery and installation of an inert gas system, the customer receives the "Delivery and connection preparation" check list in order to be able to check all prerequisites for the transport and installation conditions.

Delivery of the system components takes place on pallets (woven in / pallets with planking or wooden crate).

For subsequent transport on the customer's premises or within the building, take into account:

- The room for the installation of the system is prepared
- The transport paths (width/radii of the floors, staircase, lift) are sufficiently dimensioned and freely accessible

To be provided:

- Suitable transport vehicles – depending on the type of delivery: crane, lift truck (pallet truck), lift vehicle
- Lift, wooden slats, tools

4.4.1 Regard transport markings



Regard for transport and storage

Do not put weight on or stack transport goods



The centre of gravity of the transport goods is generally in the middle

If it is not in the middle, there is a marking on the transport crate

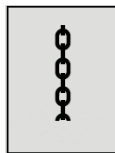

Optional for heavy load:

Specification of the attachment points

Gross weight specification
On the transport crate

Net weight, dimensions:
See delivery papers

Transport

4.4.2 Transport in wooden crates / on pallets

Prerequisite

- > Lift vehicle: minimum length: 2m
- > Keep tools ready: nail puller, tin shears



Transport to the installation room

- ▶ Transport transport goods with lift vehicle
- ▶ Open the wooden crates with crowbar, nail puller



Loosen locks on the transport goods

 **WARNING** Bands are under tension! They can fly off when cutting and cause facial injuries!



- ▶ Wear goggles
- ▶ Stand to the side of the tension direction
- ▶ Cut tension bands slowly (tin shears)
- ▶ Remove plastic film

! The rest of the transport depends on the type of system delivered.

4.4.3 Lift transport goods from the pallet, bring them to the installation location

WARNING

Risk of tipping! Risk of injury!

- ▶ Regard the position of the centre of gravity! of the transport goods!

4.4.3.1 Transport of a box + antechamber (without gas purifier)

- ! For boxes with antechambers, the lifting point is nearly in the middle, however slightly offset in the direction of the antechamber.

- For systems with antechamber:
Pick-up point in the middle below the box, slightly offset
- For systems with higher centre of gravity:
Regard the marking on the system. (If there is no marking: pick-up point in the middle below the box)

NOTICE

- ▶ Damage to the box/the frame from the forks of the lift vehicle (pallet truck)!
- ▶ Protect the edges of the box with wooden bar, as described below



Preventing damage to the frame

- ▶ Place a wooden bar on the forks of the lift vehicle
 - ▶ Move the carriers of the fork lift up until they are a little below the box
 - ▶ Align wooden bars so that they fall in line with the protruding screws
- The system is ready for transport

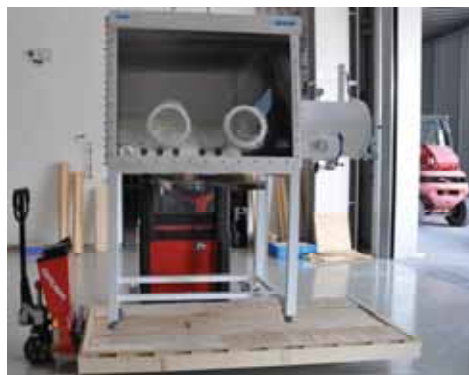

Transporting the system:

- ▶ Start up lift vehicle
- ▶ Bring transport goods to the intended location

- WARNING** Risk of damage and injury due to tipping/rolling load! Regard the following instructions when setting down the transport goods!

Transport

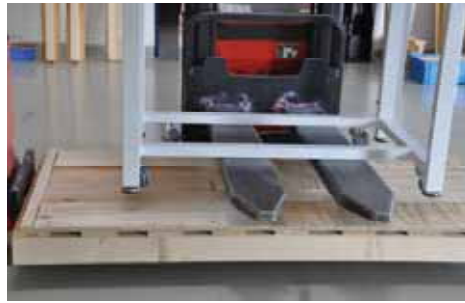

Lowering from the pallet

- ▶ Approach with the lift vehicle below the frame - a bit offset from the middle in the direction of the antechamber.

⚠ WARNING Property damage + risk of injury due to tipping/rolling load! Regard the following instructions when setting down the transport goods! Regard the following instructions when setting down the transport goods!



Setting down the transport goods

Before setting down the transport goods:

- ▶ Make sure that the weight is set evenly on the max. moved-out plate feet
- ▶ Screw in the plate feet only afterwards
- ▶ Move system on rollers slowly to its final location
- ▶ Align system
- ▶ Screw plate feet out far enough that the rollers are no longer in contact with the floor

→ This way, the system stands firmly on the floor.

4.4.3.2 Transport of a system with an integrated gas purifier

Example: Labmaster / MOD box:



Lift angles

- ▶ Screw 2 mounting lift angles on each of 4 corners/fastening points of a MOD-box
- ▶ Approach with lift
- ▶ Use transport crane

⚠ CAUTION Property damage + risk of injury due to tipping/rolling load! Regard the following instructions when setting down the transport goods! Regard the instructions above when setting down the transport goods!



Ring screw

Optional for heavy loads

- ▶ Attach lift on pre-mounted ring screws

4.4.3.3 Transport of a gas purifier with crane



Gas purifying system

- ▶ Sling lift around the 4 corners of the gas purifier

⚠ WARNING

Damage and electrical hazard!

The cable duct runs under the housing of the gas purifier (marked in red).

With improper transport, the cable duct may be damaged! This can cause damage to the cable duct and electrical hazards!

- ▶ Transport the system properly

Do not tip!



- ▶ Fasten lift on the crane
- ▶ Lift the crane hook carefully
- ▶ Check whether the gas purifier sits well in the sling
- ▶ Only then lift from the pallet
- ▶ and bring to the installation location

- ▶ Even setting down of the transport goods on the four rollers (*if no plate feet*).
- ▶ Install and align system

Transport

4.4.3.4 Transport at a later time

When transporting at a later time, also consider:

- Use wooden transport crates
- Transport on pallets
- Stabilise the transport goods against slipping with profiled timbers, aligning the rollers
- Secure loose parts (such as touch panel, antechamber tray) with bubble wrap
- Pack in film
- Transport in air-suspended truck required

(Follow the check-list "Preparation for delivery and connection" from MBRAUN)

4.5 Connection preparations - overview

Before delivery, the user receives an information sheet about the required connection accessories for his system. The following details provide a general overview.

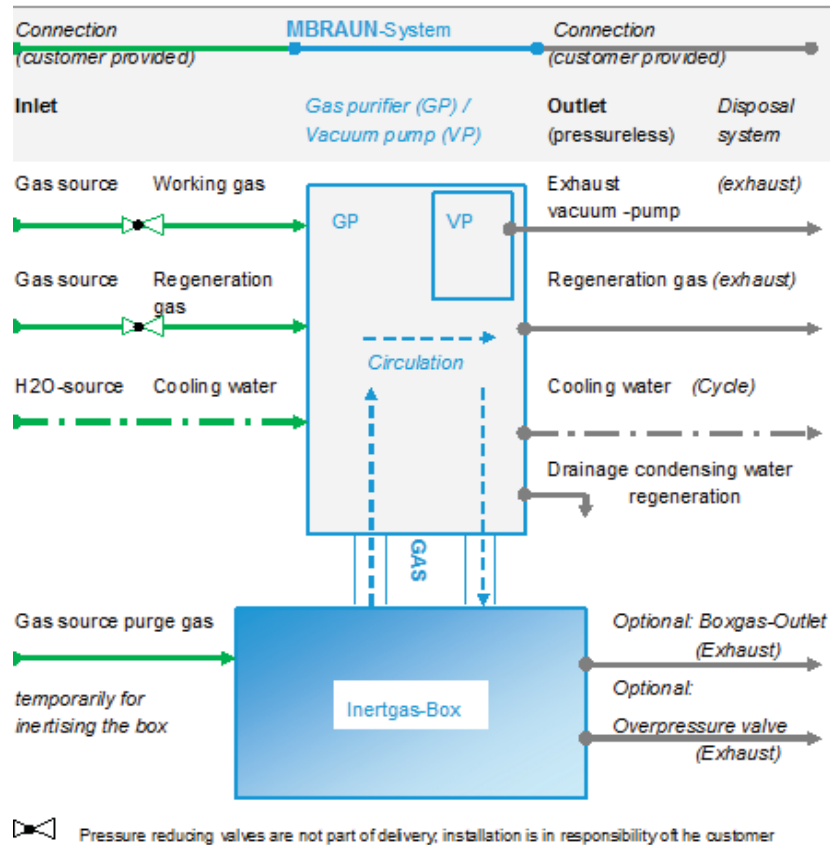

Gas purifier	INPUT (→ source for the gas purifier)			OUTPUT → for disposal equipment)		
	Input pressure – from source	Pressure / temp.	Connection		Connection	Pressure Exhaust
Operating gas / control gas	≤ 200 bar / ≤ 20 MPa	5.5 – 6.0 bar / 0.55 – 0.6 MPa	10 mm	from gas purifier + vacuum pump	KF 40 / ø 44.5 mm	Pressureless max < 0 mbar to min - 2mbar
Regeneration gas	≤ 200 bar / ≤ 20 MPa	0.3 – 0.4 bar / 30 – 40 kPa	10 mm			
Cooling water	2.0 bar / 0.2 MPa	max. 10°C – 15° C	10 mm			pressureless
Box			KF40			
Purge gas (inertisation of the box from ext. source)	≤ 200 bar / ≤ 20 MPa	5.5 – 6.0 bar / 0.55 – 0.6 MPa	10 mm		KF 40 / ø 44.5 mm	pressureless

Gases and accessories

4.6 Gases and accessories

4.6.1 Gas types

In standard systems, nitrogen, argon or helium can be used as gas types. For regeneration gas, **MBRAUN** recommends always using the same gas type as the operating and purge gas. If argon is the operating gas, then argon should be used as purge gas and an argon/hydrogen mixture should be used as regeneration gas.



Gas type: in general, only the gases named above may be used.

Other gas mixtures - including those with carbon dioxide and hydrogen - are possible. However, this requires special system preparations by **MBRAUN**, which are not a component of a standard system.



WARNING

Exceeding the concentration of hydrogen in the regeneration gas of > 10% is not permitted!

Heed the safety instructions in the chapter safety, hazards when handling gases.

4.6.2 Operating gas

Operating gas	Type / mass	Use
Gas type	Nitrogen, Argon or Helium	<ul style="list-style-type: none"> ▪ Construction and maintenance of the pure gas atmosphere: pressure regulation and purging of the box ▪ Valve control: pressure gas of electropneumatic valves and pneumatic controller
Purity	Medium purity from bottles or other supply equipment (recommended: 4.8 or better)	
Quantity	Constant supply for operation of the system	
Accessories		
Gas regulator		Pressure regulation of the operating gas
Pressure	200 bar (20 MPa) primary, 5.5-6.0 bar (0.55 – 0.6 MPa) secondary	
Flow	Flow rate 250 l/min	
Connection	3/8" hose barb	
Supply line		Connection of the gas source with the system connection operating gas IN
Material	3/8" i.d fabric reinforced hose	
Connection	3/8" hose barb	
Length	Optional (length as required):	

4.6.3 Purge gas (manual purge)

Purge Gas	Type	Use
Gas type	Like operating gas (see above)	Manual purge*) to inertise the box on (re) commissioning, intermediate purging; pressure regulation for purge gas
Purity	Medium purity from bottles or other supply equipment (recommended: 4.8 or better)	
Quantity	Approx. 10 - 12 m ³ each m ³ box volume	
Accessories		
Gas regulator		Pressure regulation for purge gas with manual purge
Pressure	200 bar (20 MPa) primary, 5.5-6.0 bar (0.55 – 0.6 MPa) secondary	
Flow	250 l/min	
Connection	3/8" hose barb	
Supply line for purge gas:		Line from the purge gas source to the inert gas box (purge gas IN)
Connection	3/8" hose barb	
Disposal line for purge gas exhaust:		Connection Purge gas OFF with the user's supply equipment (pressureless)
Connection	Extension with Ø 42 mm corrugated hose, length 100 mm and 2 hose clamps possible.	Connect hose for the purge gas exhaust directly to the disposal equipment

"QuickPurge" automatic purge

Automatic purge	Type	Use
Purge gas connection	Like operating gas connection (see above)	For quick inertisation of large-volume boxes
No connection accessories required		
Disposal line for purge gas exhaust:		Connect hose for the purge gas exhaust directly to the disposal equipment

4.6.4 Regeneration gas



Gas type regeneration RKM

MBRAUN recommends always using the same carrier gases as for the operating gas: →

Gases and accessories

see table below

Regeneration gas RKM	Type / mass	Use
Gas type	Depending on the type of working and purge gas used:	Reprocessing of saturated H ₂ O/O ₂ purification units
<i>Nitrogen is operating gas:</i>	<ul style="list-style-type: none"> Nitrogen/hydrogen mixture (90-95% N₂ with 3-10% H₂) 	<p>⚠ WARNING</p> <p>Never use hydrogen mixture with H₂ percentage > 10%!</p>
<i>Argon is operating gas:</i>	<ul style="list-style-type: none"> Argon/hydrogen mixture (90-95% Ar₂ with 3-10% H₂) 	
<i>Helium is operating gas:</i>	<ul style="list-style-type: none"> Helium/hydrogen mixture (90-95% He with 3-10% H₂) 	
Purity	Medium purity from bottles or other supply equipment (recommended: 4.8 or better)	
Quantity	Approx. 3.5 m ³ per regeneration	
Regeneration gas accessories	Type / mass	Use
Gas regulator		Pressure regulation of the regeneration gas
Pressure	200 bar (20 MPa) primary, 0.3-0.4 bar (30 – 40 kPa) secondary	
Flow	Flow rate approx. 1.25 m ³ /h (10-20 l/min)	
Connection	3/8" hose barb	
Supply line		Connection of the gas source with the system connection Regeneration gas IN
Material	3/8" i.d. fabric reinforced hose	
Connection	3/8" hose barb	

Cont. see next page

Regeneration gas accessories	Type / mass	Use
Disposal line		<p>Connection Regeneration gas OUT with the user's disposal equipment (pressureless)</p> <p>NOTE</p>
Material	3/8" mm fabric reinforced hose optional	

		See particularities exhaust of a regenerable LMF!
Connection	3/8" hose barb	

4.6.4.1 Specifics of regenerable LMF (optional)

Regeneration gas LMF	Type / mass	Use
Gas type	Only use pure inert gas – like operating gas	Reprocessing of saturated - solvent filter purification units ⚠ WARNING Do not use a hydrogen mixture!
Accessories regeneration gas LMF		
In-house disposal equipment	⚠ WARNING Explosion protection required!	Safe disposal of regeneration exhaust LMF
Disposal line		Regeneration gas OUT for regeneration gas exhaust
Material	3/8" mm fabric reinforced hose	
Connection	3/8" hose barb	

Equipment with solvent filter (LMF) + box purging:



Solvent filter (LMF) + box purging:



Regard after installation/maintenance: check correct fit of the protective fleece

Connect connecting adapters exhaust air hose to pressureless exhaust air

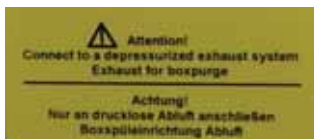

4.7 Cooling water and accessories

4.7.1 Water cooling

Not required for systems without cooling or with compressor cooling.

Cooling water:		
Use	System cooling	
Material	Tap water: Temperature: Flow rate: Input pressure: Output pressure: Conductivity (at 25°C): Water hardness pH: Fixed contamination: Microbiological contamination (algae, bacteria, moulds): Fixed contamination (overall):	10 °C – 15 °C (*mus always be above the condensation temperature) 2 l/min at 10 °C 5 l/min at 15 °C 2.0 bar (0.2 MPa) max. pressureless (max 0.5 bar (50 kPa)) < 1.0 mS /cm < 8°d (comparison value) 7 - 8 filtered, particle size ≤ 30 µm < 100 cfu/ml ≤ 150 mg / l

Connection line for cooling water	Type / mass	Use
Use		Feed and discharge of cooling water
Material	3/8" mm fabric reinforced hose	
Connection	3/8" hose barb	

 Vacuum pumps and accessories

4.8 Vacuum pumps and accessories

Vacuum pump gas purifier (VPG)	Type / mass	Use
Disposal line Material	Ø 25 mm fabric-reinforced hose and Ø 25 mm hose connector or Ø 25 mm stainless steel pipe with flange and clamp <i>Optional (length as required):</i>	Connection of the vacuum pump exhaust (oil mist and exhaust) with the user's disposal equipment (pressureless)
Separate vacuum pump antechamber VP1..2	<i>as previously</i>	Optional, for high quality requirements of box and/or antechamber atmosphere
Separate vacuum pump VPGL		For use of solvents as process material:
Disposal line Material	<i>as previously</i>	Connection of the vacuum pump exhaust (oil mist and exhaust) with the user's disposal equipment (pressureless)

4.8.1.1 Particularities: purging of the pump (optional)

Vacuum pump accessories	Type / mass	Use
Purge kit	<i>Purge kit with air filter for scroll pumps</i>	Purging of the vacuum pump if contaminated/aggressive gases escape from the antechamber into the vacuum pump

4.9 Connecting the system

Prerequisites

- > The media connections are available
- > Correct connections are available
- > Use pressure reducing valves (not included in the scope of delivery of standard systems)

4.9.1 System workstation Labmaster SP/DP

Optional: with box cooling + refrigerator + LMF (absorption principle)



Front view

Labmaster SP

Connecting the system

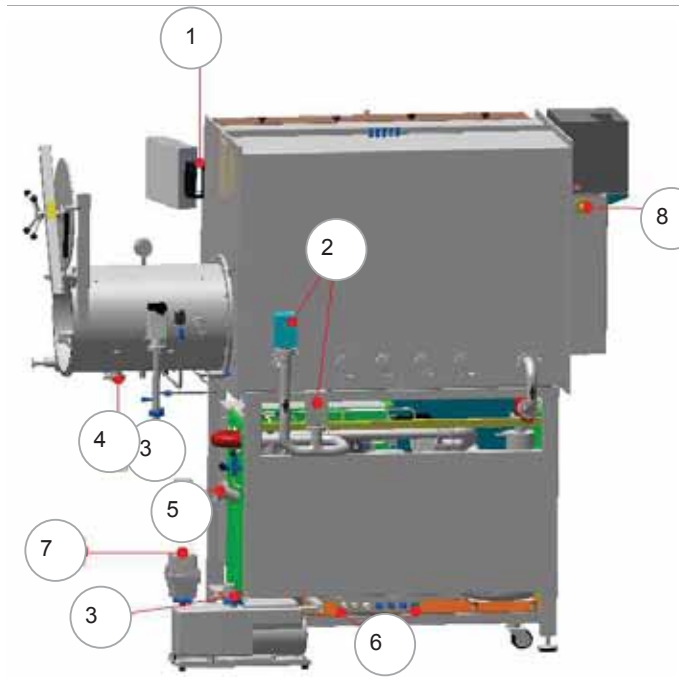

► **Connecting the system:**

- (1) Mount the operating console and make connections to the control cabinet
- (2) Insert sensors: note that the measurement cells are installed in the middle of the gas line
- (3) Connect antechamber to vacuum pump
- (4) Gas input antechamber refill
- (5) Fill necks active carbon for LMF (Option – see below)
- (6) Media connections (see detail)
- (7) Optional: exhaust of the vacuum pump to exhaust air system
- (8) *see following page: detail of box cooling / refrigerator*

System with LMF + RKI

Detail: media connections

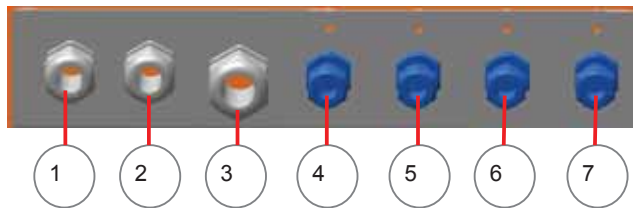

- | | |
|----------------------------------|----------------------------|
| (1) Electrical mains connection | (4) Operating gas input |
| (2) Mains connection vacuum pump | (5) Regeneration gas input |
| (3) Condensate return | (6) Cooling water input |
| | (7) Cooling water output |



Connection of earthing bolts (next to the bar for media connections)

! Follow the marking on your system! The assignment of the connections may differ according to the customer.

Optional: System box cooling and/or refrigerator/freezer

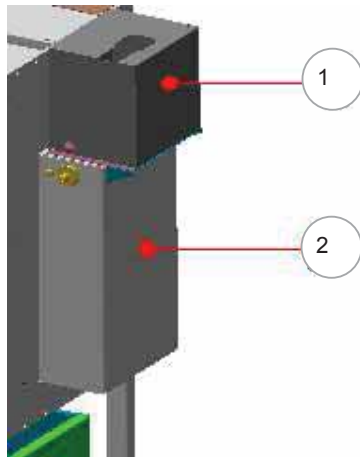

- (1) Box cooling RKI (see separate manual)
- (2) Refrigerator/freezer

Connecting the system

4.9.2 System with gas purification platform MB20/MB200 G with MOD-Box

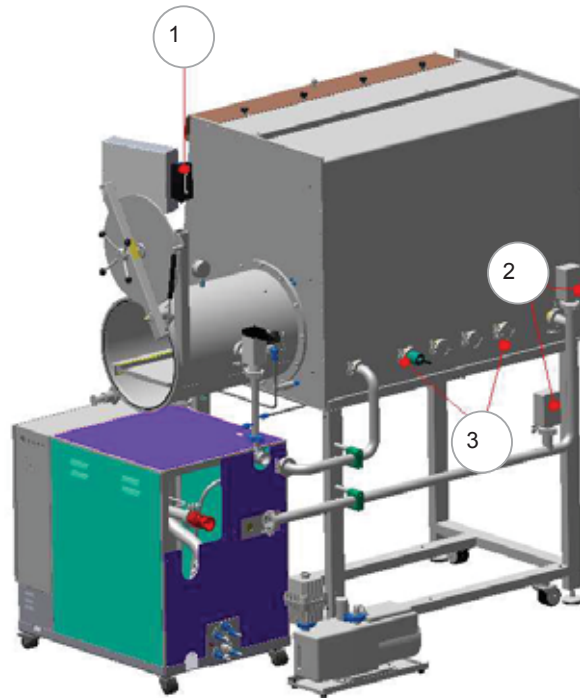

► Installation of accessories

- (1) Mount separately packaged operating console
- (2) Insert sensors: make sure that the measurement cells are installed in the middle of the gas line - lay cables from the GR unit in the cable ducts - connect colour of the cable + sensors so they match + plug in RJ45 connector
- (3) optional: customer-specific feedthroughs

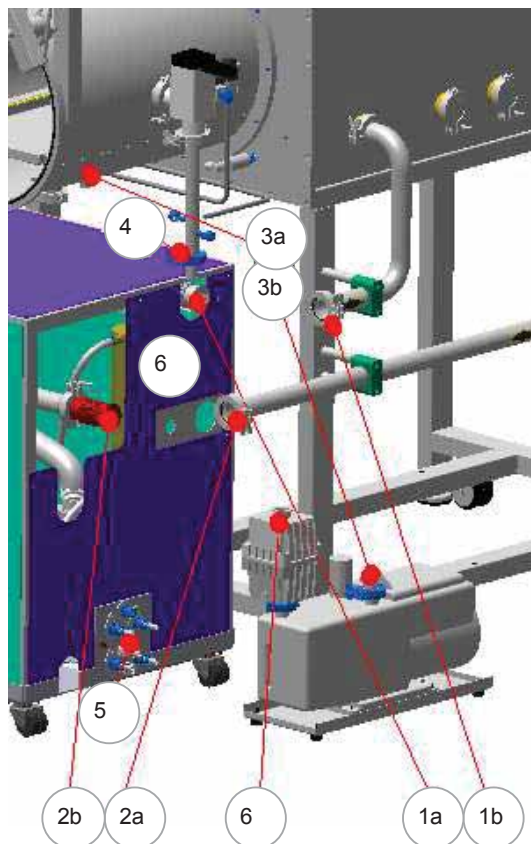

► Connect box and gas purifier (GR):

if necessary, connect with corrugated hoses/stainless steel pipe:

- (1) a) Output GR + b) Input box (circulation)
- (2) a) Output Box + b) Input GR (circulation)
- (3) a) Antechamber + b) Vacuum pump
- (4) Input antechamber refill (here: from GR)
- (5) Media connections (see below for details)
- (6) Connect exhaust vacuum pump if necessary to the in-house exhaust line

optional: customer-specific connections

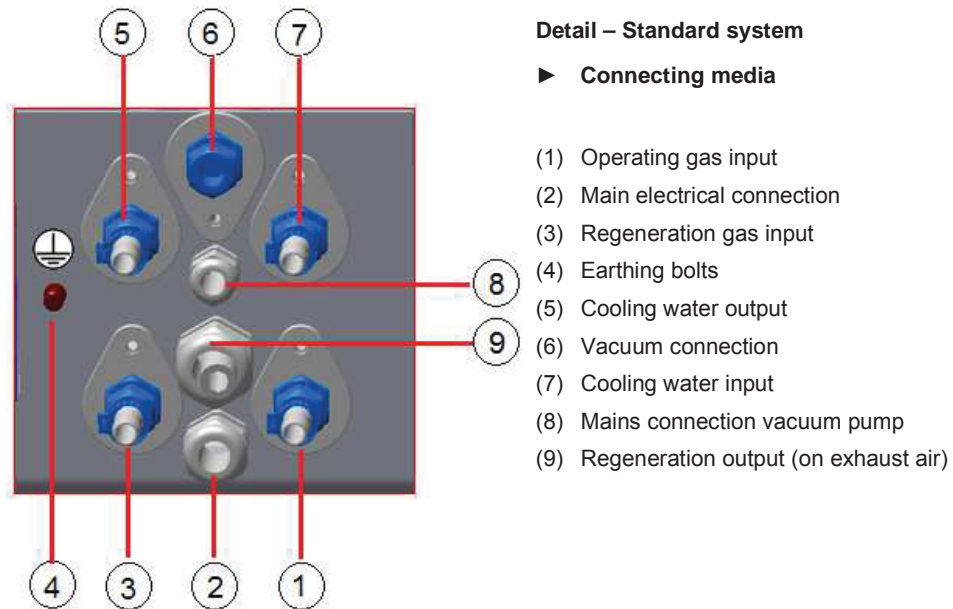

! Follow the marking on your system! The assignment of the connections may differ according to the customer.

4.9.3 Connecting the operating gas

- Connect pressure reducing valve to operating gas source (heed manufacturer's connection instructions).
- Connect supply line between gas source and system connection Operating gas IN. (the precise input pressure is specified on the system connection "Operating gas IN")
- Set pressure reducing valve to this value
- Open pressure reducing valve.

! **In standard systems:**
One connection: operating gas simultaneously takes over the function of the control gas

In modular systems:
Separate connections for operating gas and control gas

Connecting the system

4.9.4 Connecting the regeneration gas

- ▶ Connect pressure reducing valve to regeneration gas source (heed manufacturer's connection instructions).
- ▶ Connect supply line between gas source and system connection **Regeneration gas IN**. (the precise input pressure is specified on the system connection "Regeneration gas IN")
- ▶ Set pressure reducing valve to this value and
- ▶ Open pressure reducing valve.

4.9.5 Connecting disposal line for regeneration gas



DANGER

Risk of personal injury and environmental damage in case of escape of used regeneration gas!

- ▶ Regard the information of the gas supplier about adverse health and environmental effects
- ▶ Discharge used regeneration gas via an exhaust disposal system which is designed for the degree of hazard of the process materials used

In case radioactive or toxic materials are used, do not discharge gas into the environment!

See also Chap. 3. 2 Proper use

- ▶ Establish disposal line between system connection Regeneration gas OUT and disposal equipment.
 - Connection is pressureless

4.9.6 Disposal line for vacuum pump exhaust

- ▶ Establish disposal line between exhaust output of the vacuum pump and the disposal equipment (heed vacuum pump manufacturer's operating manual)

→ The connection is pressureless

! Depending on the location of the system and the vacuum pump, an exhaust filter can be used instead of a disposal line.

In case of questions, please contact **MBRAUN** Service.

4.9.7 Connecting the cooling water

Not required for systems without cooling or with compressor cooling.

- ▶ Establish system connection **Cooling water IN** to cooling water source.
- ▶ Establish system connection Cooling water OUT to disposal equipment. The connection must be pressureless (max. return pressure: 0.5 bar (50 kPa)).
- ▶ Open cooling water (the required flow quantity depends on the water temperature)

! Systems with additional or specially-cooled components may require a separate coolant supply.

4.9.8 Installing sensors (optional)

See also Chap. System description as well as Technical Data for measurement devices in the annex.

The sensors are inserted in the pipework (at the box output).

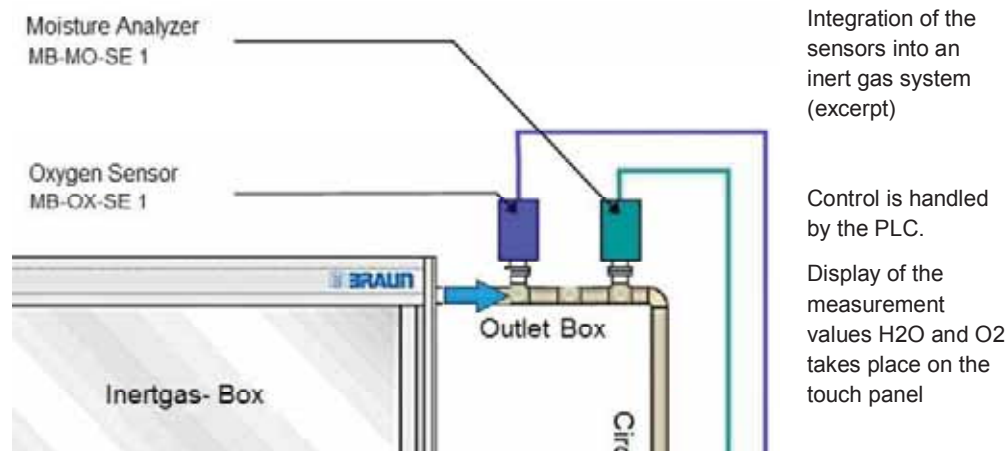

Connecting the system

4.9.8.1 Oxygen sensor MB-OX-SE1

Connection

The oxygen measurement device is connected using a RJ45 connector (8-pin).

Installation

- ! Before applying the supply voltage, the sensor should be subjected to the inert gas for at least 1 minute.
-

The oxygen sensor is fastened with a vacuum-tight NW40 flange using centring ring and clamp.

- ! The sensor may only be connected to the PLC controller if the complete system is sufficiently purged with inert gas, *see Chapter "Inert gas box, inertising the box"*.
-

4.9.8.2 Moisture measurement device MB MO-SE-1

Connection

- ▶ Connect the moisture measurement device using a RJ45 connector (8-pin).

Installation

- ! Before applying the supply voltage, the sensor should be subjected to the inert gas for at least 1 minute.
-

- ▶ Fasten the moisture measurement device with a vacuum-tight NW40 flange using centring ring and clamp.
-

- ! The sensor should only be put into operation after sufficient purging of the box: that is, with an O₂ concentration < 100 ppm.
-

4.9.9 Mains supply



DANGER

Risk of personal injury due to electrical voltage in case of error: uncontrolled muscle reactions, crippling, burns or death can result!

- ▶ All work on the mains connection and the electrical system may only performed by a trained electrician.

1. Standard systems:

- ▶ Connect to current source: with mains plug (Schuko plug or country-specific)

2. Special systems:

- ▶ Connect the open mains connection line to a fused and earthed current source. Connection values: see type plate and wiring diagram (see Chap. 13)

4.9.10 Potential equalisation

Due to increased leakage current(EMC filter current), an additional potential equalisation according to EN 60204-1 is required.



Safety-Equipotential Grounding
 connect system with main grounding bus bar
 system line leakage current > 10mA
 required conductor cross-section > 10mm² Cu

Schutz-Potentialausgleich
 Anlage mit Potential-
 ausgleichsleiter verbinden
 Mindestquerschnitt > 10mm² Cu

M8 bolts on the rear side of the gas purifier
(see above):

- ▶ Connect green-yellow cable with 10 mm² Cu to the local potential equalisation

Follow the instruction on the system
(below the main switch)

Installing additional components

4.10 Installing additional components

Follow the descriptions in the optional additional chapters (7-10 A..X).

4.11 Acceptance

The acceptance test will be performed by **MBRAUN** service technicians if the installation and commissioning were done by **MBRAUN**.

In case of installation and initial commissioning by the customer, an acceptance test and functional inspection must be conducted before operating the system.

! **Customer's responsibility:**

For delivery of a system that will be integrated into a customer's system or into which additional customer components will be integrated, the customer guarantees compliance with the machine directive 2006/42/EC.

5.1	Introduction	5-2
5.2	Safety	5-2
5.3	Touch panel with screens and buttons	5-3
5.3.1	<i>Start screen</i>	5-3
5.3.2	<i>Navigation</i>	5-5
5.3.3	<i>System components screens</i>	5-6
5.3.4	<i>Functions screen</i>	5-8
5.3.5	<i>Parameters screen</i>	5-10
5.3.6	<i>Trend panel screen</i>	5-12
5.3.7	<i>Warnings and error messages panel screen</i>	5-13
5.4	Service	5-13
5.4.1	<i>Monitoring and testing</i>	5-14
5.4.2	<i>System information</i>	5-15
5.5	Pre-set parameters	5-21
5.6	Overview	5-24
5.6.1	<i>Navigation from the start screen (System components und functions)</i>	5-24
5.6.2	<i>Menu screen selection</i>	5-25
5.6.3	<i>Components screen</i>	5-26
5.6.4	<i>Service screen selection</i>	5-30

5 Controller

5.1 Introduction

This chapter will present the basic principles of the controller:

- Structure and function of the touch panel with screens
- Navigation between the individual screens of the system and of the components
- The display of process data (measurement values, status processes)

Controller architecture:

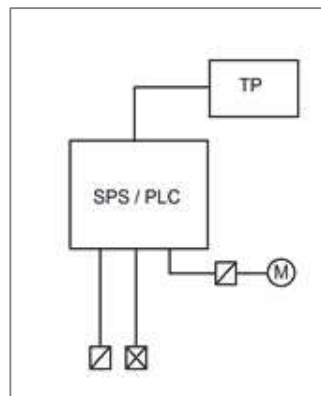

Basic principle

TP touch panel

SPS / PLC controller

5.2 Safety

The controller of the standard systems is designed for normal operation with non-dangerous processes/process materials. Some of the parameters that are pre-set can be adapted to customer-specific conditions in the course of the minimum/maximum values (*cf. Pre-set parameters in Chap. 5.6*).

Parameterisation may only be done by qualified personnel.

As an additional option, a password concept with various access authorisations can be set up (not included in the standard scope of delivery).

If there are increased safety requirements for your applications that require controller-technical additional functions:

- ▶ Please contact **MBRAUN** Service.

5.3 Touch panel with screens and buttons

By default, **MBRAUN** systems are equipped with a PLC and a touch panel. The touch panel is the central operating and display unit of the system. It is in a central, easy-to-see position.

After it is switched on, the system boots up automatically. After a brief wait, the start indicator appears.

The start indicator maps the configuration of the system with the main components and serves as the operating interface. It looks different depending on how the system is equipped.

5.3.1 Start screen

Start screen

01102-1

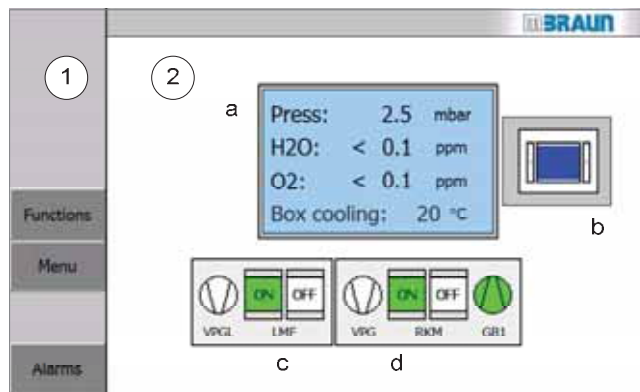

Structure

- (1) Navigation bar
- (2) Operator panel with
 - Indicators (a) and (b)
 - Symbol buttons / buttons (c) and (d)

Structure of start screen

(1) Navigation bar

- Navigation to functions and menu
- Alarms: display of alarm at issue and navigation to warning list (see 5.3.6)

(2) Operator panel

The operator panel contains status indicators and buttons with navigation functions (see following section for explanation).

In the example: gas purifier with 2 purifiers (RKM) and solvent filter (LMF) with 2 filters and separate vacuum pump (VPGL)

Touch panel with screens and buttons

5.3.1.1 Symbol buttons of the system components

The system components are shown as symbols on the start screen. The symbols indicate the status of a component; sometimes they are buttons with navigation functions.

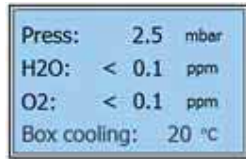

Symbol for the box

- Display values box pressure + box atmosphere (residual content H2O and O2)
- Display values temperature freezer / box (optional)
- Touch the symbol button: → call up the "Box parameters" screen



Symbol for the antechamber

- Display values box pressure + box atmosphere (residual content H2O and O2)
- Display values temperature freezer / box (optional)
- Touch the symbol button: → call up the "Box parameters" screen

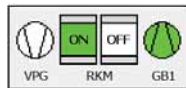

Symbol for the reactor (removal of H2O / O2) Ex. equipped with:

- Touch the symbol button: → call up the "Gas purifier" screen

VPG: Vacuum pump

- Status indicator

RKM: Reactor *Standard: 1 RKM / optional: 2 RKM*

- Status indicator

Blower (GB)

- Status indicator

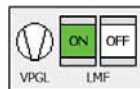

Symbol for the solvent filter unit

- Touch the symbol button: → call up the "Solvent filter" screen

(optional)

Ex. equipped with:

▪ Vacuum pump (VPGL) (optional)

- Status indicator (separate vacuum pump for the solvent filter)

▪ Gas purifier solvent (LMF) optional: 1 or 2 LMF

- Touch the button: → call up the "Solvent filter" screen

5.3.2 Navigation

Navigation to the various screens of the touch panel can be accomplished

- Symbol buttons (see above)
- Navigation bar buttons
- Buttons on the "Menu Screen Selection" screen

5.3.2.1 Navigation bar buttons

The bar with the navigation buttons is on the left side of the touch panel. These differ depending on the screen.

BACK	Touch the button: Back to the previous screen
END	Touch the button: Back to the start screen
Alarms	ALARM button red: error in operation, system error or component failure Status: see 5.3.6

5.3.2.2 Navigation using the Menu Screen Selection

With the "Screen Selection" screen type, subordinate screens are called up:

- Menu Screen Selection (example)
- Service screen selection menu (see Chap. 5.4)

Menu Screen Selection

01120

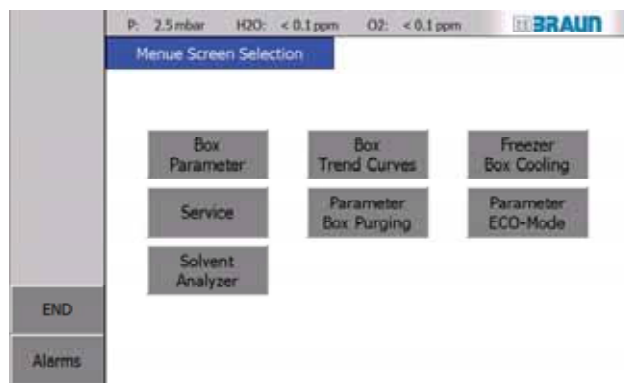

Structure

- (1) Navigation bar
- (2) Navigation buttons:

Navigating:

Touch the buttons, to call the corresponding screens

! The buttons will vary depending on how the system is equipped.

Touch panel with screens and buttons

5.3.3 System components screens

The screens for the components of the system gas purifier and antechamber are structured according to the following principle:

Purification Unit screen

01310-2

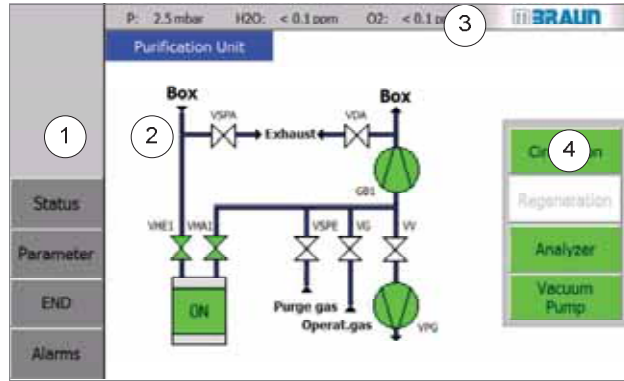

Example

- (1) Bar with navigation buttons
- (2) Scheme of the system components
- (3) Permanent display: measurement values
- (4) Operator panel with function buttons



For more information, consult:

- the overview of the panel screens and their activation (*Chap. 5.7*).
- Details for operation of the individual system components in the respective chapters (*7, 8, 9 and 10 (optional)*)
- The system component "box" is operated using the "Menu Screen Selection" (*for details see Chap. 8*).

Status indicators RKM / LMF

Status indication of the symbols:





The graphic symbol buttons indicate the respective functional status by their colour:

Status of the gas purifier (RKM):





	OFF / WHITE	Not active
	ON / GREEN	Purification function active - in circulation operation
	RED / MAGENTA	Regeneration of the reactor
	RED / MAGENTA	Regeneration / heating up

Touch panel with screens and buttons

Status indicators: designations of valves

	GREEN	Valve open
	WHITE	Valve closed
	RED	Failure of the valve / error
	YELLOW	Abnormal state *)

Status indicators: vacuum pump / analog: blower

	GREEN	switched ON
	WHITE	switched OFF
	RED	Failure / error
	YELLOW	Abnormal state *)

***) Explanation of "non-normal state":**

	YELLOW	<p>Example "Non-normal state of blower":</p> <p>Symbol displayed in yellow: if, for example, a function is switched on but not yet active, because prerequisites are not yet fulfilled: <i>Example: system with 2-filter LMF: circulation RKM is switched on – however the blower is not yet running since no LMF filter was switched into circulation.</i></p>
---	--------	---

Touch panel with screens and buttons

5.3.4 Functions screen

Quick operation:

The "Functions" panel screen (1, 2..) offers direct access to the function buttons without detouring to the component screens.

Functions screen 1

01160-1

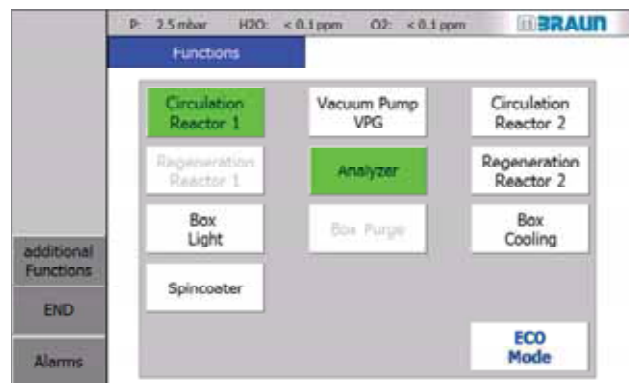

Structure

- (1) Navigation:
additional functions:
 call Function screen 2
- (2) Activate/deactivate functions using buttons

Functions screen 2

01161

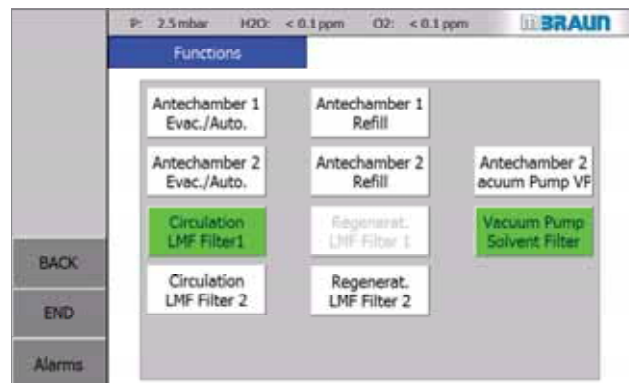



Example

Functions 2 with additional components (optional)

! Only function buttons are depicted whose associated components are also actually present in the system.

Touch panel with screens and buttons
Functions: Status indicators

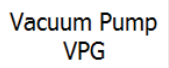
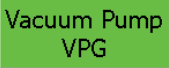
Function buttons are displayed differently depending on their status:

	White background, black type	switched OFF
	Green background, black type	switched ON
	White background, grey type	Function is switched OFF – switching ON is locked
	Green background, grey type	Function is switched ON – switching OFF is locked

Touch panel with screens and buttons

5.3.5 Parameters screen

Parameters

Parameters are pre-configured at the manufacturer.

Some parameters for the system or system components can be adapted in a defined range. They are set on the respective screen.

The input of system parameters, alarm specifications, passwords or the selection of important options is done using input fields.

Display field



Black type:

Display of process values, not adjustable

Input field:



Blue type:

Display and change of process variables

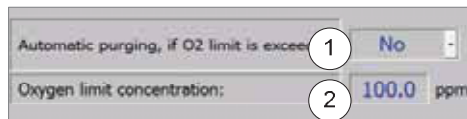

(1) Pull-down menu

(2) Alphanumeric input field

(1) Pull-down menu

If you touch the input field on the pull-down menu:

→ The selection menu is displayed.

- ▶ Select the desired element
- Selection menu closes
- Selected value is displayed

(2) Alphanumeric input field

If you touch the alphanumeric input field:

→ Button field opens

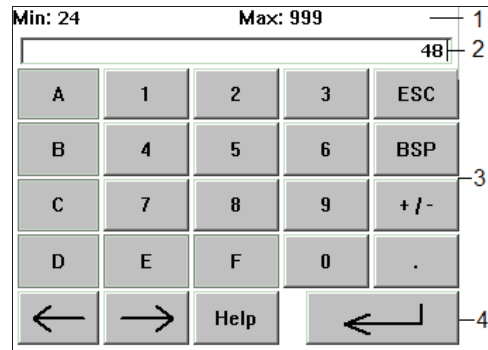

(1) Min / Max of allowed parameter range

(2) Input field: display of input value

(3) Input buttons

(4) **Enter** button

▶ Input by touching the input buttons

▶ Confirm with Enter button

→ Button field closes

→ New input value appears in input field.

Touch panel with screens and buttons

5.3.6 Trend panel screen

Trend curves indicate the temporal course of process values:

- Box trend curves: (H₂O, O₂ and box pressure) (display of other values optional)
- Antechamber trend curve: pressure

Antechamber trend curve screen

01602

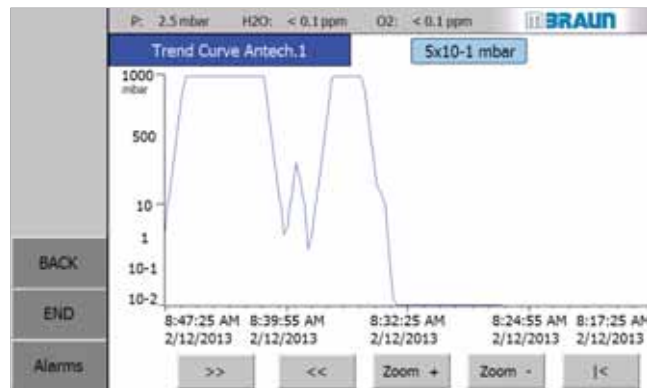

Example:

The time axis of the diagram runs from right to left:

The current values are displayed on the left side.

X - axis = time scale – division into hours and minutes
Y- axis = measurement values of physical units (*here: pressure in mbar*)



Shift time axis



Stretch or compress time axis

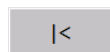



Return to the current time

5.3.7 Warnings and error messages panel screen

The "Alarm" button is displayed on all system and function screens on the navigation bar. The status of the button indicates function error (system error or component failure) :

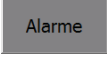
Status:

	Static	No message present
	Flashing	One or more messages present, one or more messages not acknowledged
	Static	One or more messages present, all messages acknowledged

See Chap. 11.1

5.4 Service

Using the "Service" screen, the functions for monitoring and checking of system components and system information are called up.

Service: Screen Selection

01700

Navigation (optional) to

- (1) Monitoring + Test
- (2) System Information

Navigation:

Buttons call the corresponding screens:

- (1) Monitoring + Test:
 - hours of operation
 - H2O sensor
 - box-pressure-sensor
 - pressure control valve
- (2) System information:
 - OS services (password, calibrate screens, etc.)
 - Info
 - Service **MBRAUN** (only accessible to **MBRAUN** Service)

Service

5.4.1 Monitoring and testing

5.4.1.1 Service Operating Hours (electric drives)

Using the display of the operating hours of an electrical drive, inspection and maintenance cycles can be determined and monitored.

Service: Operating Hours

01703

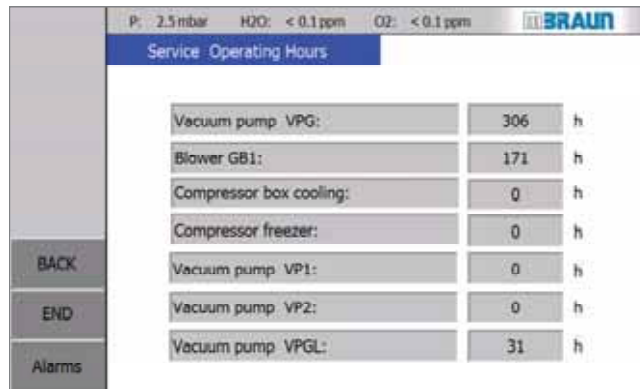

Component	Operating Hours (h)
Vacuum pump VPG:	306
Blower GB1:	171
Compressor box cooling:	0
Compressor freezer:	0
Vacuum pump VP1:	0
Vacuum pump VP2:	0
Vacuum pump VPGL:	31

Electrical drives:

Display of operating hours for

- Vacuum pumps
- Blower
- Compressor box cooling
- Compressor freezer

5.4.1.2 Service: H2O sensor

The regular maintenance of the sensor is monitored with the "Service Moisture Analyzer" screen. A warning is triggered after 2000 hours of operation.

Service Moisture Analyzer

01705

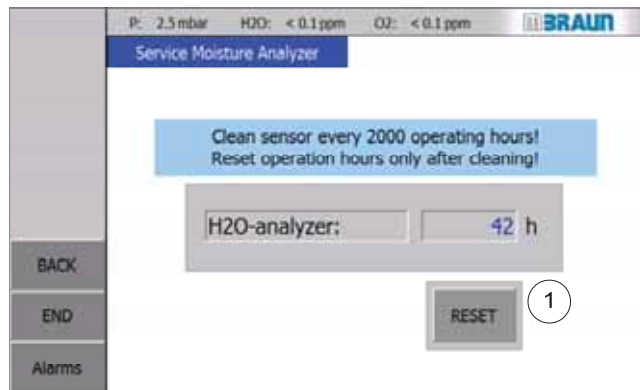

Cleaning the H2O sensor:

See Chap. 12 Inspection and maintenance

After cleaning the H2O sensor:

- ▶ Reset the hours of operation to zero with the **Reset** button (1)

5.4.1.3 Service: cyclical check of the pressure control valve

Optional: cyclical check of the box pressure control valve (MB-OSV)

Service: cyclical check of the pressure control valve

01706-1

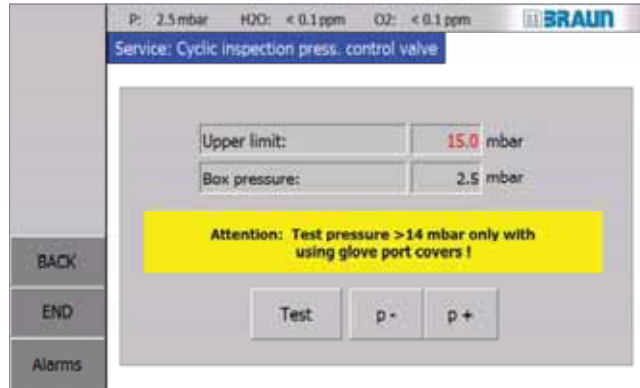

See Chap. 12 Inspection and maintenance

5.4.2 System information

5.4.2.1 OS Services

Operation System – services (OS services)

01702

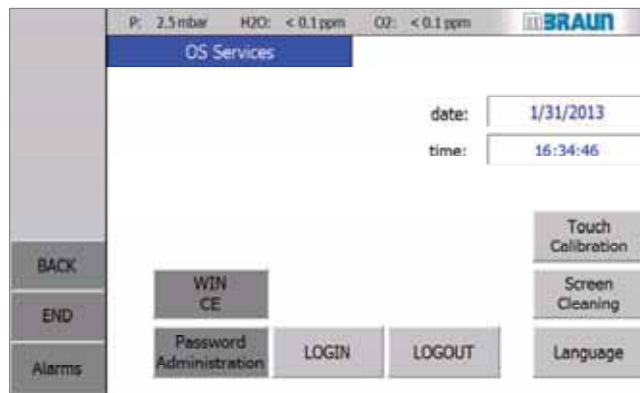

Date + Time

Date and time

date:

time:

Is pre-set by the manufacturer to Eastern Time (US)

Note:

If in a region where daylight savings time (DST) is observed, this change must be made manually.

Settings on the touch panel

! Protection of the surface of the touch panel:

A plastic stylus should be used for navigation and settings on the touch panel.

Protective film:

A self-adhesive protective film is optionally available for the screen. The protective film protects the touch panel against soiling and scratches. The matte surface of the protective film also reduces the reflections on the display. The protective film can be applied at any time without tools, removed or replaced.

Never use hard or sharp objects (e.g. a knife) to remove the protective film.

1. Calibrating the touch panel

"OS Services" screen

To calibrate the touch position on the screen:

- ▶ Touch the "Touch Calibration" button

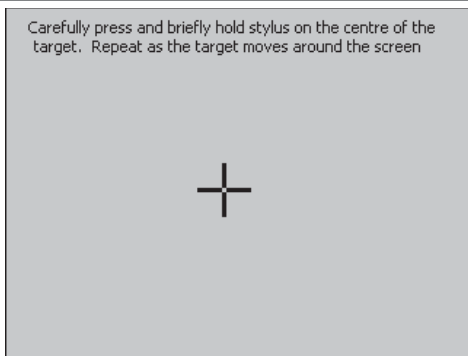
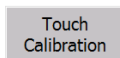

Touch the centre of the target cross briefly and carefully with a suitable plastic stylus. Repeat procedure after the cross has moved within the display field.

After successful input, the following message is displayed:

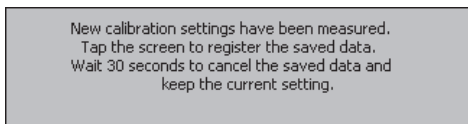

The new calibration data has been recorded. Touch the touch panel to save the data. If the new calibration should not be saved, please wait 30 seconds. The inputs are reset automatically to the previous setting.

 Service

 2. Cleaning the screen

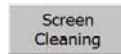
"OS Services" screen

Before cleaning the screen:

- ▶ Touch button 

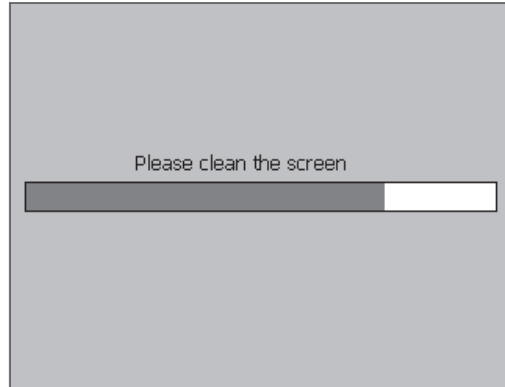

A non-sensitive display is called up.

A time bar counts down 30 seconds:

 During this time the screen can be cleaned with a damp, soft cloth.

3. Setting the language

 By default, **MBRAUN** systems have German and English user guidance.

Other language are available on request.

"OS Services" screen

Select language:

- ▶ Touch button 
-

4. Ending the panel runtime system with WIN CE

 The runtime system is ended with WIN CE and the touch panel switched to the operating system level.



! The system can no longer be operated with the touch panel if the runtime system has ended!

"OS Services" screen

Ending the runtime system:

- ▶ Touch button 
-

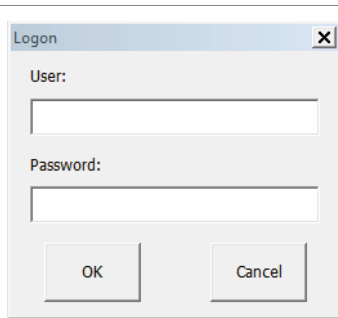
5. LOGIN / LOGOUT (user / password entry)

	<p>The "Logon" dialog window is called up with the "LOGIN" button</p>
	<p>"Logon" screen</p> <p>The user and password are input using the alphanumeric input field</p> <p><i>Password management: see below</i></p>
	<p>The user logs out with LOGOUT.</p> <p>If there is no input, the system logs out automatically after 5 minutes.</p>

6. Password Administration (optional)

On this screen it is possible to assign personal passwords to the subordinate authorisation level.

Password Administration

01707-1

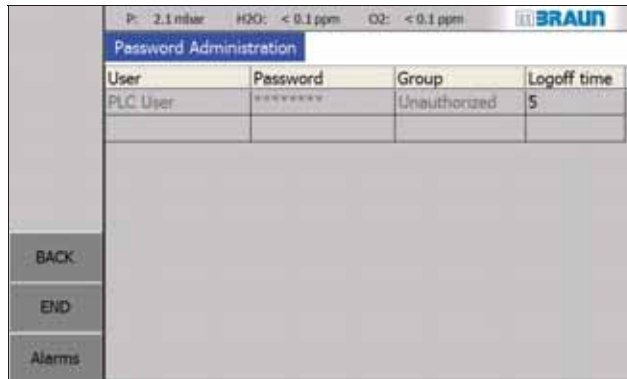

Optional:
See additional chapter "Password concept"

 Service

5.4.2.2 Info

The "Info" screen contains the **MBRAUN** contact data. In the lower field are project-specific details such as project number, if necessary serial number of the system and software version.

Info screen

01701



(1) Contact data

(2) Project data

5.4.2.3 Service MBRAUN

*This screen is only accessible to **MBRAUN** service technicians.*

5.5 Pre-set parameters

The parameters for inert gas systems are set up at the manufacturer for a standard system (see *Setting parameters in Chap. 7-9*).

Parameter MBRAUN basic systems	Manufacturer setting value	Unit	min	max.	Set value Customer	
					min	max
General system parameter						
• Purge box: switch off autom. after	60	min	0	999		
• Antechambers: lock inner door after	60	min	0	500		
• Normal speed circulation blower	100	%	60	100		
• H ₂ percentage regeneration gas	≥5	%	<5	≥5		
Regeneration duration	150 / 300	min	no limit	no limit		
ECO-Mode parameters (optional)						
• Automatic activation of ECO-Mode	Yes/no					
Time for automatic activation	17:00:00	o'clock	00:00	24:00:00		
• Speed reduction circulation blower	Yes/no					
Reduced speed	60	%	60	100		
• Automatic switch-off vacuum pump. VPG / VPGL	Yes/no					
Automatic switch-off vacuum pump. VP1 / VP2	Yes/no					
Run-on time vacuum pumps	60	min	30	600		
Automatic switch-off box light	Yes/no					

Pre-set parameters

Parameter MBRAUN basic systems	Manufacturer setting value	Unit	min	max.	Set value Customer	
					min	max
Gas purifier RKM / LMF						
• Start circulation automatically after regeneration	Yes/no					
• Regenerate automatically	Yes/no					
Regeneration interval	25	H	24	999		
• Alarm threshold LMF analyser	1	V	0,1	9,9		
Box					min	max.
• Box pressure: upper operating limit	+4,0	mbar	-13,5	+14,5		
• Box pressure: lower operating limit	-4,0	mbar	-14,5	+13,5		
• Hysteresis Upper Limit	2,0	mbar	0,5	calculated		
• Hysteresis Lower Limit	2,0	mbar	0,5	calculated		
• Box pressure: upper alarm limit	+15,0	mbar	-14,0	+15,0		
• Box pressure: lower alarm limit	-15,0	mbar	-15,0	+14,0		
• H2O alarm	20,0	ppm	5,0	499,0		
• O2 alarm	20,0	ppm	5,0	999,0		
2-box system: pressure monitoring						
• Maximum pressure difference Box 1 – Box 2	1	mbar	0	5		
Freezer / box cooling						
• Target value temp. freezer	-35	°C	-40	+10		
• Temperature alarm freezer	-25	°C	-40	25		
• Target value temp. box cooling	20	°C	10	40		
• Temperature alarm box cooling	30	°C	10	50		

Touch panel with screens and buttons

Parameter MBRAUN basic systems	Manufacturer setting value	Unit	min	max.	Set value Customer	
					min	max
Box automatic purge						
• Automatic purge in case of O2 exceeding	Yes/no					
O2 limit value	100,0	ppm	10,0	999,9		
Box pressure monitoring						
• Maximum pressure difference Box 1 - Box2	1	mbar	0	5		
Antechambers					min.	max.
• Threshold value intermediate refill	400	mbar	1x10 ⁻²	50		
• Threshold value vacuum leak test	5x10 ⁻¹	mbar	1x10 ⁻²	10		
• Threshold value final vacuum	5x10 ⁻¹	mbar	1x10 ⁻²	10		
• Number of pump refill cycles	1		1	10		
• Maximum evacuation time	5	min	1	20		
• Maximum leakage rate	3	steps	1	10		

Overview

5.6 Overview

5.6.1 Navigation from the start screen (System components und functions)

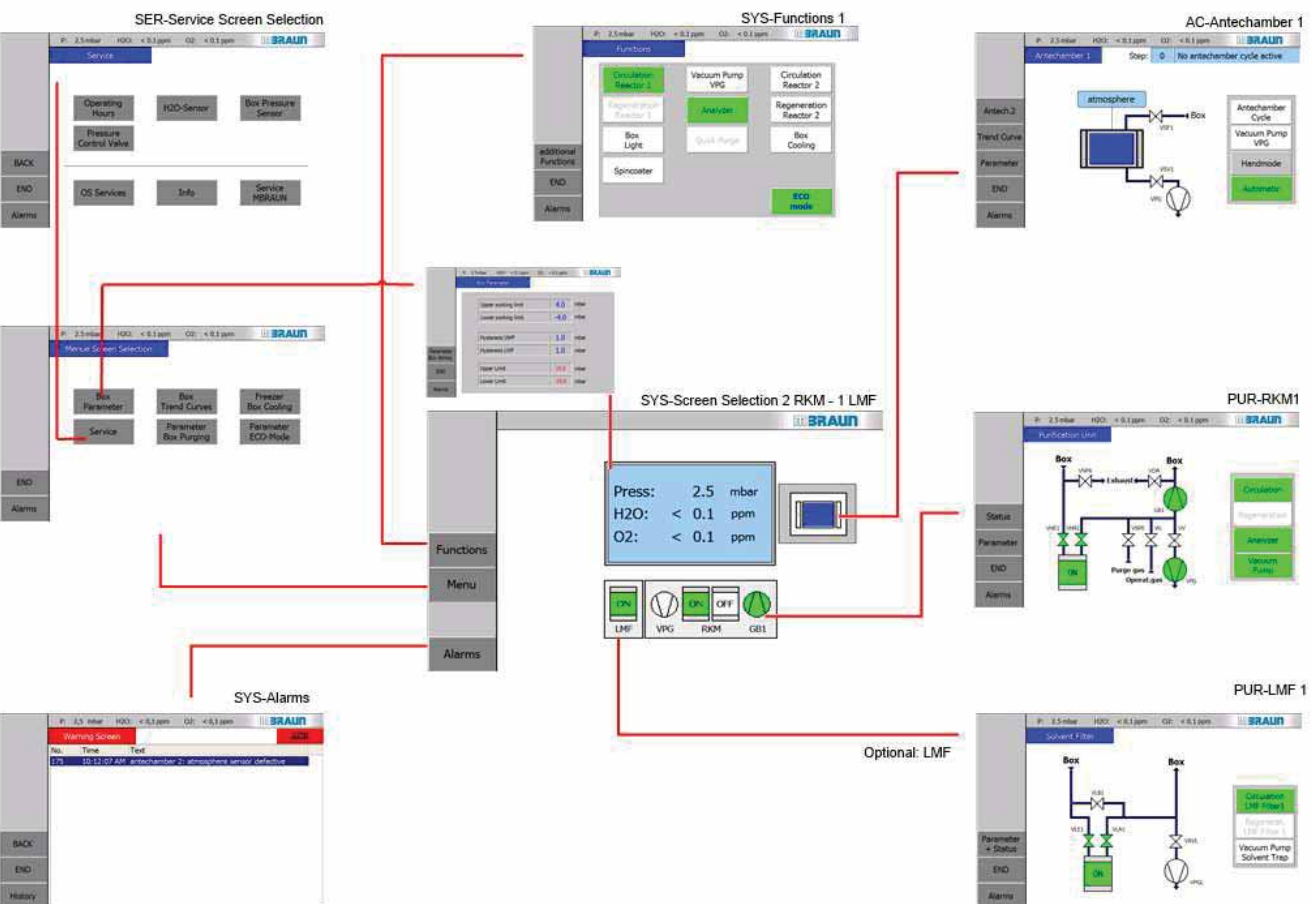

5.6.2 Menu screen selection

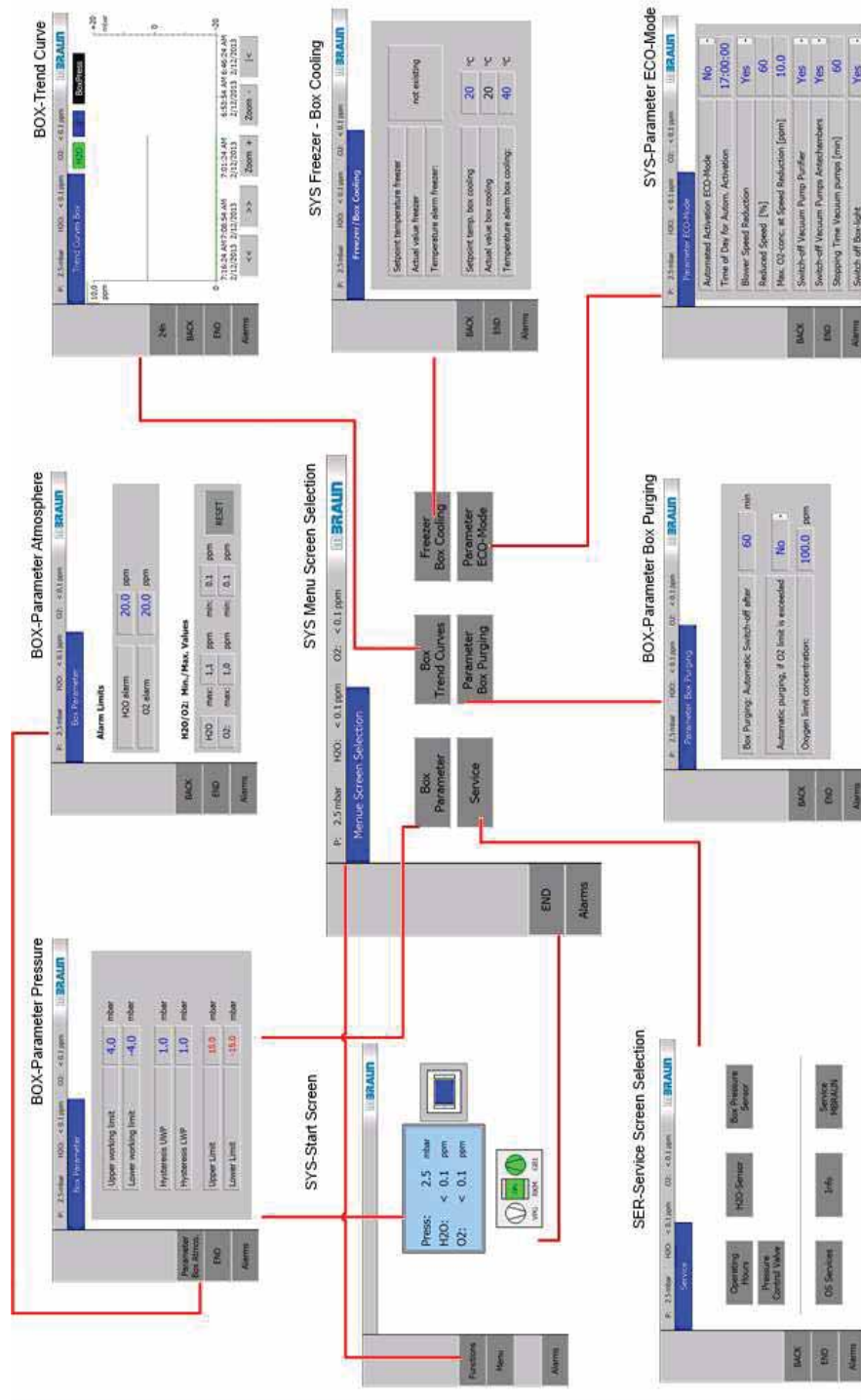

Overview

5.6.3 Components screen

5.6.3.1 Gas Purification RKM

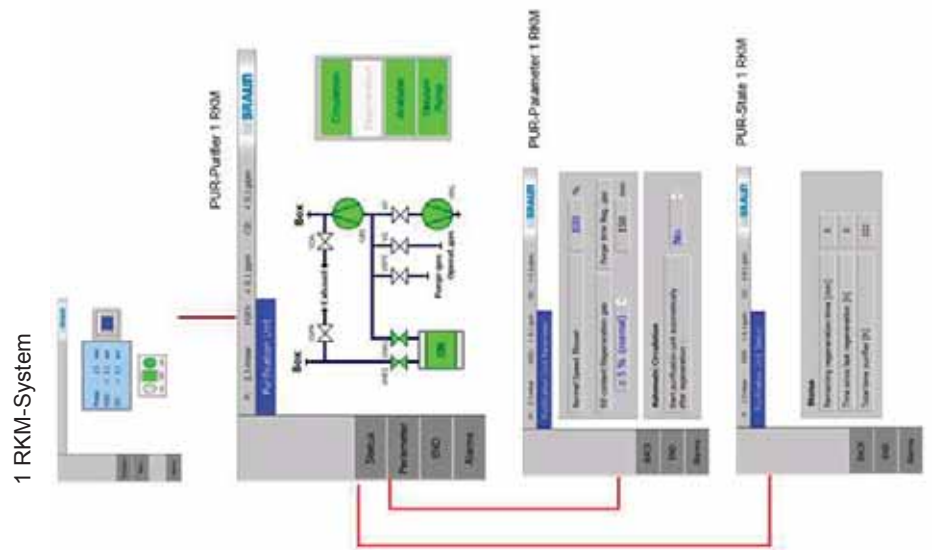
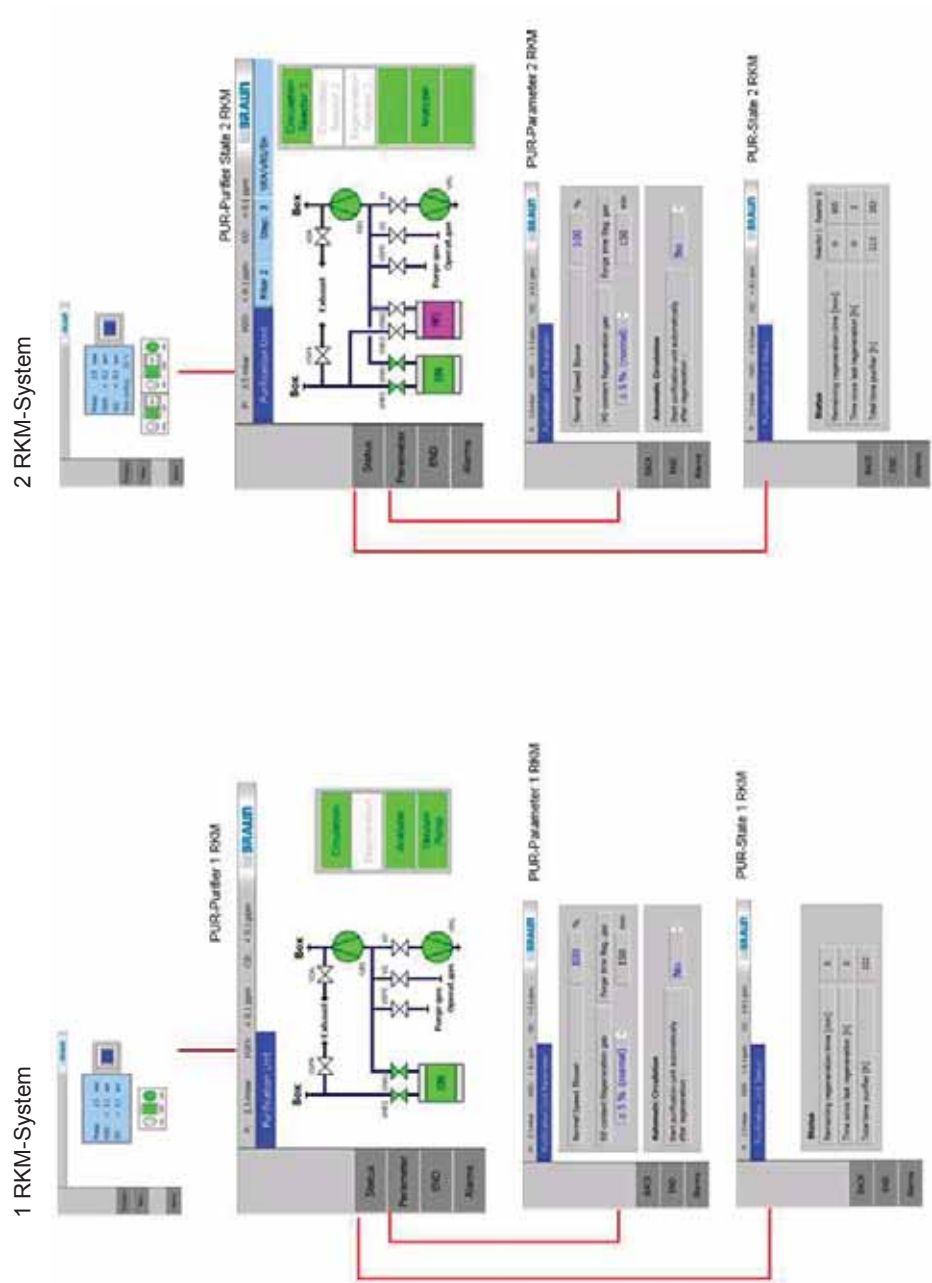

5.6.3.2 Gas Purification with LMF

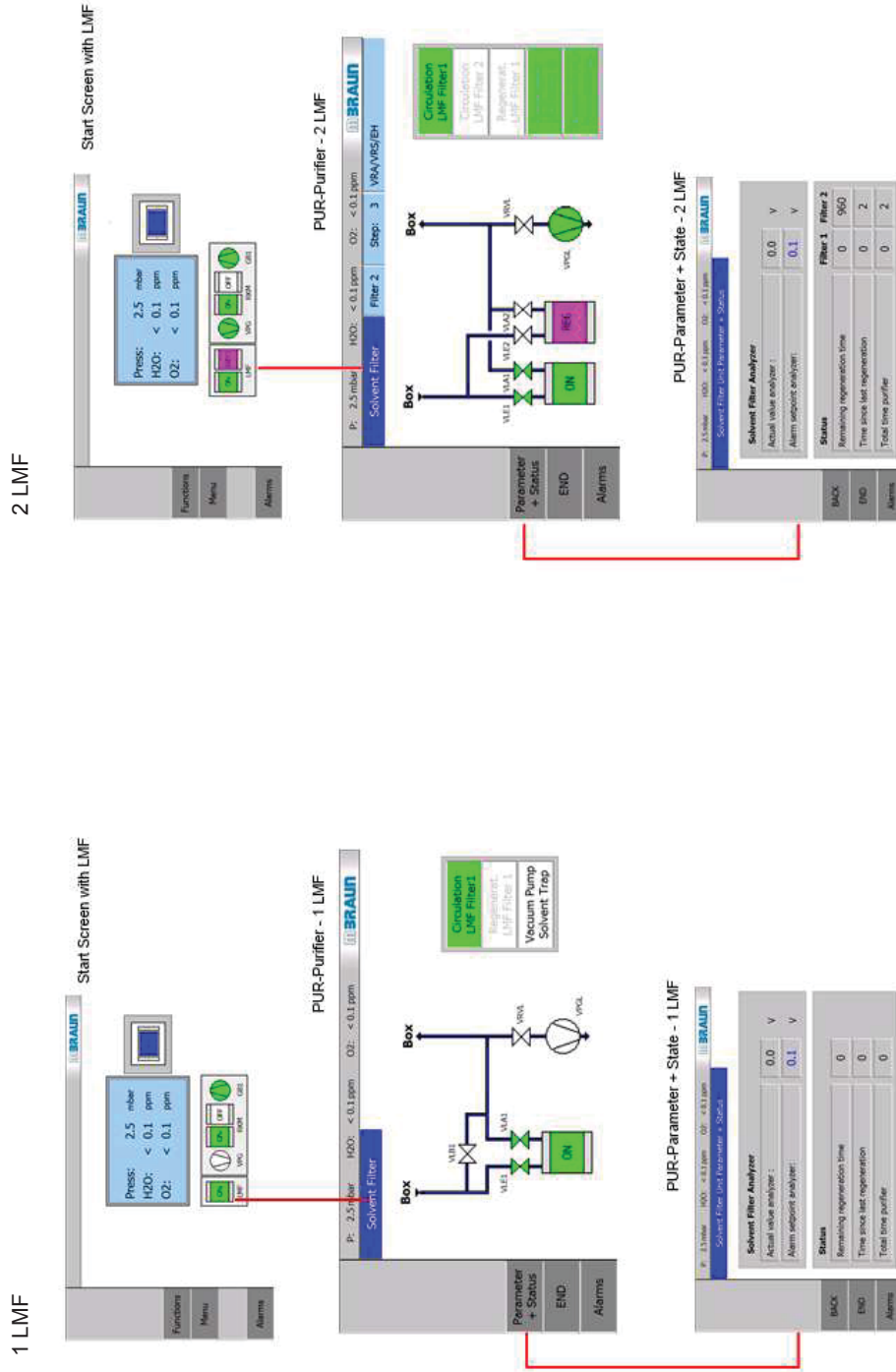

Overview

5.6.3.3 Inert Gas-Box

See chapter 5.6.2 Menu screen selection

5.6.3.4 Antechamber (Automatic)

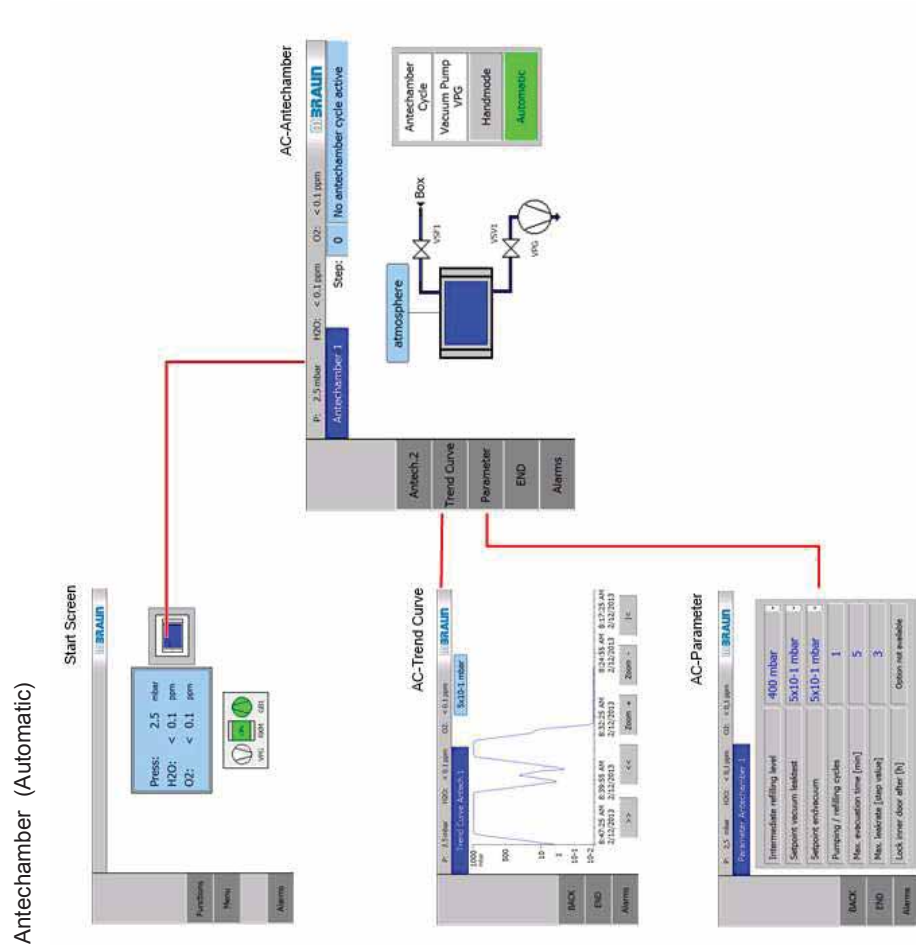

5.6.3.5 Antechamber (Manual)

Antechamber (Manual)

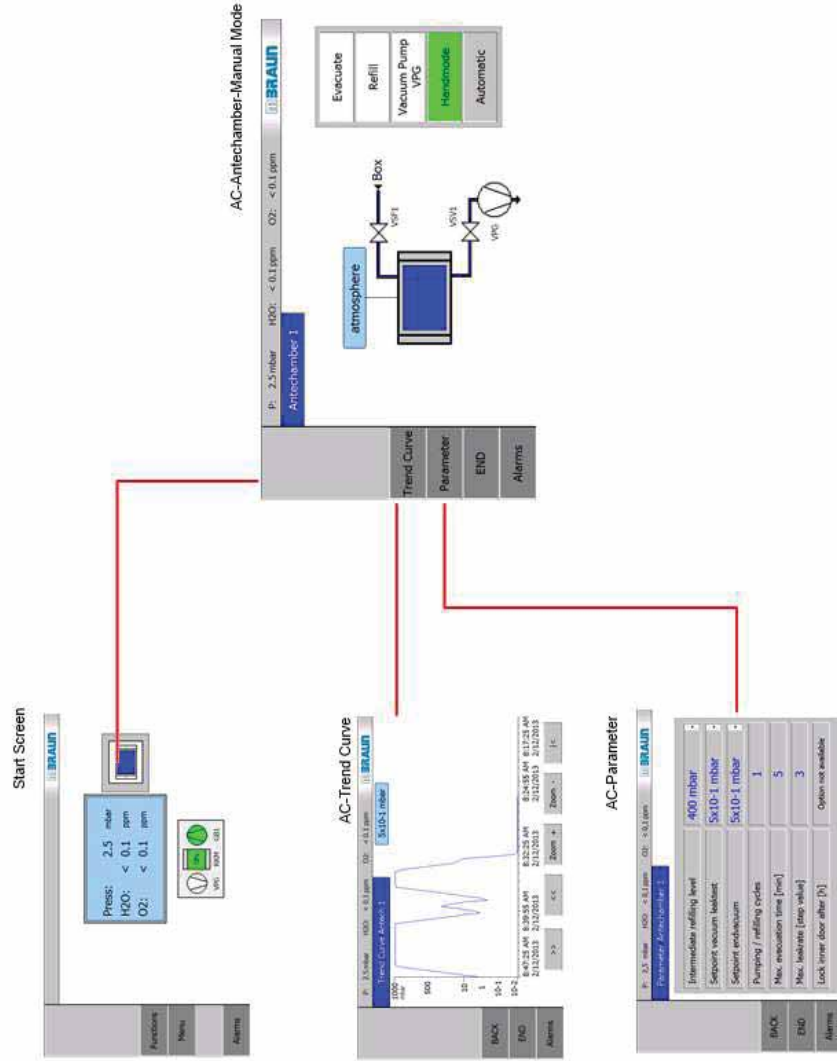

Overview

5.6.4 Service screen selection

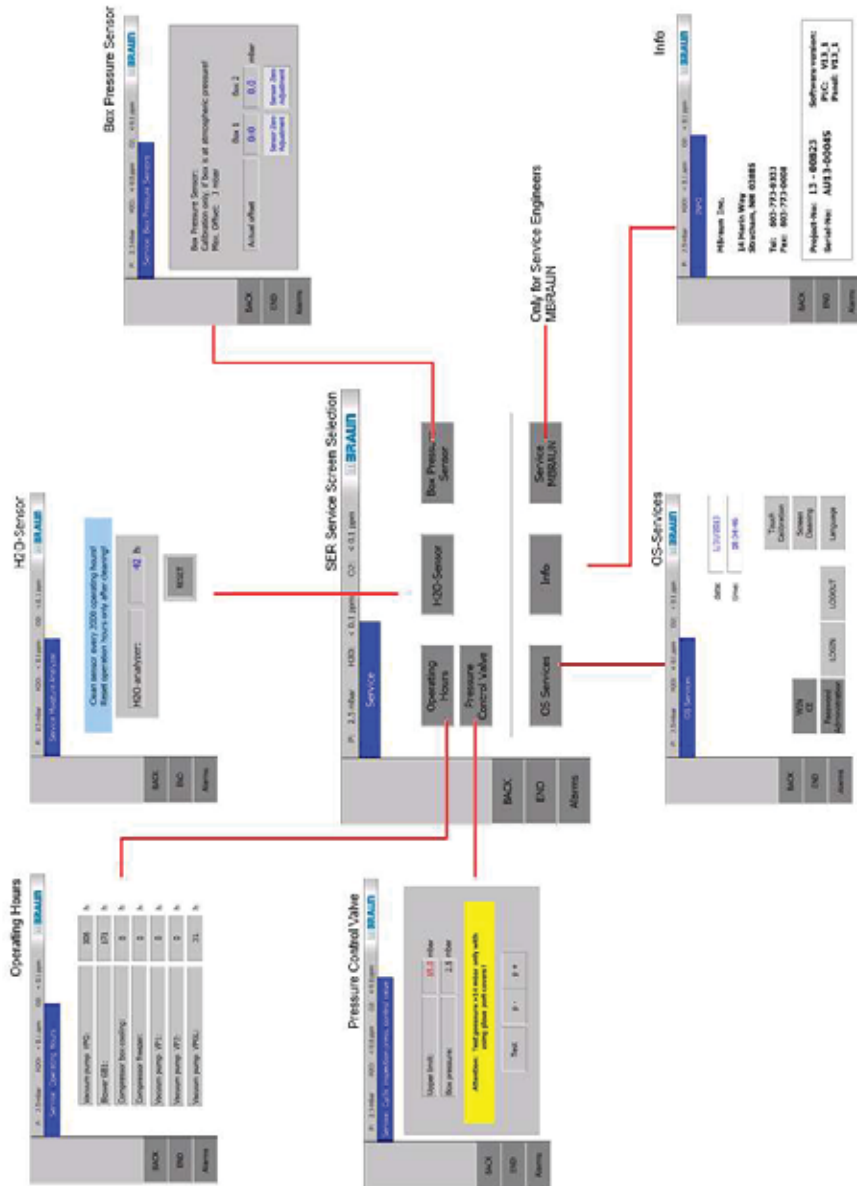

6.1	Introduction	6-2
6.1.1	<i>Overview of operating modes and activities</i>	6-2
6.2	Safety	6-4
6.2.1	<i>Operating Manual</i>	6-4
6.2.2	<i>Personnel</i>	6-4
6.2.3	<i>Environment</i>	6-5
6.3	Prerequisites for operation	6-6
6.3.1	<i>Organisational preparation</i>	6-6
6.3.2	<i>Check connections</i>	6-6
6.4	(Initial) commissioning	6-7
6.4.1	<i>Switch system on</i>	6-7
6.4.2	<i>Inertising the box (pre-purging)</i>	Error! Bookmark not defined.
6.4.3	<i>Inertisation of the pipework</i>	6-8
6.5	System in normal operation	6-9
6.5.1	<i>Regeneration operation</i>	6-9
6.5.2	<i>Circulation operation</i>	6-10
6.5.3	<i>Antechamber cycles evacuate - refill</i>	6-10
6.6	System in ECO-Mode (optional).....	6-10
6.7	Setting up the controller for the specific processes	6-11
6.7.1	<i>Adapting parameters to process values (test run)</i>	6-11
6.8	Switching the system off	6-12
6.8.1	<i>Prerequisites</i>	6-12
6.8.2	<i>Deactivating the system</i>	6-12
6.9	System in maintenance operation	6-13
6.9.1	<i>Maintenance.....</i>	6-13
6.9.2	<i>Repair.....</i>	6-13
6.10	Damage to the system – behavior in case of emergency.....	6-14
6.10.1	<i>Damage to the system</i>	6-14
6.10.2	<i>Eliminating faults</i>	6-14
6.10.3	<i>Behavior in case of emergency</i>	6-14
6.11	De-installing the system – disposing of components	6-17
6.11.1	<i>Disposal</i>	6-17

Introduction

6 Basic operating modes

6.1 Introduction

This chapter provides an overview of the operation of the system in the course of the life cycle with commissioning – operation – decommissioning – uninstalling and disposal.

The safety of a system depends on the correct use and operation of the system.

The following overview shows the operating modes, the basic activities, and names the responsibilities and authorisations.

6.1.1 Overview of operating modes and activities

Operating mode	Activities	Responsible / authorised	See chap.
Commissioning	Organisational preparation	Operator of the system	4
	Check connections *)	Technician / User / MBRAUN Service	4
	Purging the box *)	Technician / User / MBRAUN Service	8.5
	Purging the pipework / the entire system(RKM + vacuum pump + additional equipment) *)	Technician / User / MBRAUN Service	
Standard processes	Set up specific parameters(if necessary)	if necessary Administrator / authorised people	5
	Operation in circulation mode	Trained users	7.3.2
	Operation in regeneration mode	Trained users	7.3.2
	Antechamber processes	Trained users	9
ECO-Mode (optional)	Set up parameters	if necessary Administrator / authorised people	56 A
Service / Maintenance	For more details, see <i>Chap. 12 Maintenance</i>	In-house service personnel / MBRAUN Service	812

Operating mode	Activities	Responsible / authorised	See chap.
	Cooling	Trained AC technician	10 A ff
	Electrical system	Trained electrician	
Decommissioning	Switching off the system	In-house service / Trained users	6.8
	Deactivation (<i>short-term/long-term</i>)	In-house service / Trained users	6.8
	Disposal of components of the system	Operator of the system / Trained users	6.11

*) With commissioned installation by the manufacturer: **MBRAUN** Service technician

Safety

6.2 Safety

6.2.1 Operating Manual

**DANGER**

Incorrect operation of the system can cause unknown risks, which can result in severe to deadly injuries

- ▶ Always keep operating manual within reach of the system
 - ▶ The personnel must read and understand the operating manual
 - ▶ Heed operating manual during all work: this includes preparation, transport, storage, installation, commissioning and service!
 - ▶ Always heed safety instructions in this operating manual
 - ▶ Heed safety instructions for third-party components (see supplier documentation).
-

6.2.2 Personnel

**WARNING**

Personal injury and environmental damage due to incorrect operation

- ▶ The system may only be operated and maintained by suitable qualified* and specially-trained personnel who have reached the legal minimum age.
 - ▶ Temporary personnel or personnel being trained, taught or engaged in general training may only operate the system under the constant supervision of an experienced person!
 - ▶ Work on electrical equipment of the system and its accessories may only be performed by a trained electrician or trained people under the direction and supervision of a trained electrician according to the electrotechnical regulations.
 - ▶ Work on systems with coolants may only be performed by trained air conditioning technicians.
-

* A suitably qualified person is anyone who due to his/her specialist training, as well as knowledge of the applicable stipulations, can assess the work assigned to him/her and can recognize possible hazards.

6.2.2.1 Responsibilities for operation of the system

WARNING

Endangerment of products and people with operation by several people, triggered by potential misunderstandings or uncoordinated operation.

If the deployment of several people is required:

- ▶ Define responsibilities clearly (*see Chap. 5, Password concept*)
 - ▶ Explain steps precisely to one another
 - ▶ If necessary, follow the process-specific standard operating manual
-

6.2.2.2 Protective equipment / additional equipment

WARNING

Personal injury in case of missing (additional) protective equipment and functions

Heed all details of this operating manual relating to protective equipment and accessories.

- ▶ Wear personal protective equipment (PPE) as described for the task in question in the operating manual
 - ▶ Additional equipment and functions for personal protection must always be used with the use of processes / materials that threaten health and the environment.
-

6.2.3 Environment

WARNING

Environmental damage in case of incorrect application / incorrect operation

Heed all details of this operating manual relating to protective equipment

- ▶ Discharge of exhaust in an in-house exhaust system
 - ▶ Proper disposal of components
 - ▶ Adhere to all applicable national regulations and provisions
-

Please note

- Chapter 3 Safety
 - Chapter 6.11 De-installing the system – disposing of components
-

Prerequisites for operation

6.3 Prerequisites for operation

6.3.1 Organisational preparation

Prerequisites:

- > The operating manual is ready
- > The personnel has read and understood the operating manual
- > The personnel is instructed and trained
- > Personal protective equipment (insofar as required) is ready

System-specific processes and materials (responsibility of the customer)

- > Processes and process materials used have been checked for their hazard potential
- > If necessary, a process-specific standard operating manual created by the customer is ready

6.3.1.1 Setting up the service book

- Note beginning of operation (for determination of the regeneration cycle)
- Scheduling for calibration of the sensors, maintenance intervals

6.3.2 Check connections

Prerequisites

- > All required instructions in the foregoing chapter have been heeded
- > All supply lines and connections for **gases, electricity** and **cooling water** have been made properly and checked

Exhaust:

- > Exhaust line for used regeneration gas created properly
- > Exhaust discharge of the vacuum pump(s) assured
- > Exhaust gases that harm the environment and health are connected to an in-house exhaust system
- > With use of regenerative solvent filters: connection to an explosion-proof exhaust system is required

Safety equipment:**DANGER**

Personal injury due to lacking or non-functional safety equipment!

- ▶ The normal operation of the system is only permissible with all associated, correctly-installed and functioning safety equipment!

6.4 (Initial) commissioning

6.4.1 Switch system on

6.4.1.1 Activate system



The main switch is on the control cabinet of the system.

Activate system:

- ▶ Turn main switch to I (**ON**)
- After the activation, the system performs a self-test.

! All error messages that appeared before the start screen are controller errors and can only be remedied by **MBRAUN** Service.

6.4.1.2 Start messages

By default, **MBRAUN** systems are equipped with a PLC-controlled touch panel. The touch panel is the central operating and display unit of the system. It is in a central, easy-to-see position.

After performing the self-test, the start indicator appears:

Start screen

01100-0

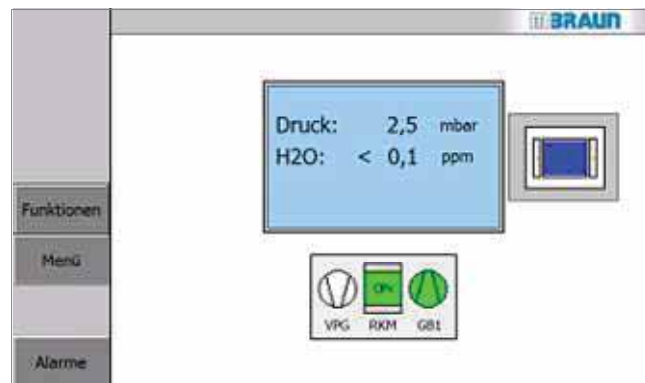

Depending on how the system is equipped, the start screen may look different. See Chap. 5 Controller.

*(Initial) commissioning***6.4.2 Purging the box**

If an inert gas box system contains ambient air – as on commissioning, in case of error or after service work – the box must be purged before switching on circulation operation.

NOTICE

Ambient air (oxygen and moisture content) damages gas purifier purifiers!

- Never switch a box with ambient air into circulation operation!

Before switching a (regenerating) purifier into circulation operation:

- ▶ Replace ambient air with operating gas



If the system is equipped with a Manual LMF style Solvent Trap the LMF will need to be in Bypass Mode prior to activating the purge function. Failure to do so will result in carbon dust accumulating at the Purge exhaust valve (VSA). VSA may need to be cleaned if this occurs.



Please inform yourself initially about the measurement devices in *Chap. 8.4 Sensor monitoring*. To purge the box, please follow the description in *Chap 8.5 Manual purge of the box (without / with measurement devices)*.



If the system is equipped with a pressure control valve, when the trigger pressure is exceeded, gas escapes through the pressure control valve into the laboratory or into the exhaust system.

Before switching the purifier into circulation operation:**Inertisation method**

- ▶ Purge box with inert gas from external source until there is an O₂ level in the box atmosphere of less than 100 ppm

After manual inertisation: adjust measurement devices

- ▶ Activate measurement devices
- ▶ Wait until the sensors work and the desired atmosphere reigns.

6.4.3 Inertisation of the pipework**Before connecting to the gas purifier / before commissioning:**

In modular systems (multi-box operation), whose pipework has a larger volume:

- ▶ Purge pipework with operating gas using the purge valve.

6.5 System in normal operation

The system delivered by **MBRAUN** is set up for normal operation (see Chap. 5.6.1 Pre-set parameters).

Normal operation of the components of the system is described in

Chap. 7 Gas purification system

Chap. 8 Inertgas box

Chap. 9 Antechamber

Chap. 10 Additional equipment (optional)

6.5.1 Regeneration operation

The RKM 1 purifying unit is regenerated by the manufacturer before delivery.

On initial commissioning, the circulation operation can run via the first purifier (RKM1).

System with 2 purifiers:

Before initial commissioning by the customer:

- ▶ Regenerate the purification unit RKM2

The distances between the regeneration cycles vary according to the system, usage type and time (see Chap. 7.3.2.3). They can be determined as follows:

Method for determining an appropriate interval for the regeneration:

After initial commissioning: wait for detectable performance drop

When there is a performance drop, note the operating duration.

The operating duration less 10 hours = reference value for the intervals between the regeneration cycles

In case of recommissioning after a longer time:

- ▶ First regenerate purifier.

System in ECO-Mode (optional)

6.5.2 Circulation operation

Circulation operation can take place:

- Using a regenerated purifier (RKM)
- Always only using one purifier.

! The activation of the circulation is only allowed if the box is inertised and the oxygen content of the box atmosphere is < 100ppm – see *Chap. 7.3.2.1*.

While the inert gas box is in operation and the measurement devices are switched on, the concentration of water vapor, oxygen and box pressure is monitored and continuously displayed on the touch panel (see *Chap. 5*):

6.5.3 Antechamber cycles evacuate - refill

Materials that are required for a process are brought into the inert gas box via the antechamber and removed from there. During the loading, the ambient air is replaced in the antechamber step by step with operating gas (inert gas) and the box atmosphere is adapted. This requires several cycles of evacuation and refilling.

The parameters for the values of number, duration and pressure of the respective cycles can be set process-specifically.

See *Chapter 9.5.2.2: Antechamber parameters*

6.6 System in ECO-Mode (optional)

ECO-Mode provides an energy-saving operating mode.

See *optional Chapter 6 A ECO-Mode*

6.7 Setting up the controller for the specific processes

6.7.1 Adapting parameters to process values (test run)

Depending on the customer-specific process, it may be necessary to adapt the parameters for processes. For this, test runs should be evaluated and logged (test run in circulation mode, determination of the regeneration intervals).

! The adaptation of the parameters is permitted to the extent specified in "Proper use" - see *Chap. 4*.

An adaptation of the limit values ensures the specific conditions for the respective processes.

Typical settings / operating values are

- Alarm limits for oxygen and water vapor
- Upper and lower limits for box pressure
- Maximum evacuation time for the antechamber
- Regeneration intervals

Input parameters see Chapter 5.3.5 Parameter screen.

Switching the system off

6.8 Switching the system off

6.8.1 Prerequisites

The system should only be switched off for the following reasons:

- in case of emergency
- during extended maintenance (e.g. in case of replacement of purifiers, particle filters or valves)
- if the system will not be used for a longer period (4 weeks and longer)

6.8.2 Deactivating the system

The system may only be switched off if all running processes are ended and deactivated, e.g. regeneration programme, circulation operation and antechamber processes.



The main switch is on the control cabinet of the system.

Deactivating the system:

- ▶ Turn main switch to **O (OFF)**.

! If the gas purifier is switched off for a longer period of time, the concentration of oxygen and water vapor inside the inert gas box increases continuously.

6.9 System in maintenance operation

6.9.1 Maintenance

Chapter 12 describes the maintenance cycles and work for an inert gas system. It is specified there who is authorised for which work.



DANGER

Risk of suffocation when performing work on an open inert gas box!

Before opening a box

- ▶ Always replace inert gas atmosphere with ambient air
- ▶ Do not place head in an antechamber if it is not ensured that the antechamber is filled with ambient air (O₂ content > 19.5%).

- ▶ An electrical inspection must be performed after all maintenance/decommissioning.

See *Inspection and maintenance chapter*

- ▶ All modifications must be documented by the customer and if necessary agree upon with **MBRAUN**.

Recommendation

Always keep the following spare parts on hand, for example

- Gloves
- Particle filter
- Oxygen and moisture sensors

6.9.2 Repair

Repair work that is not described in this manual may only be performed by **MBRAUN** Service.



DANGER

Personal injury due to non-authorised work on the system!

Maintenance work (repairs) may only be performed by **MBRAUN** Service.

In case of damage to the system:

- ▶ Contact **MBRAUN** Service.

Damage to the system –in case of emergency

6.10 Damage to the system –in case of emergency

6.10.1 Damage to the system

**DANGER****Personal injury due to damage to the system!**

Depending on the type and scope of the damage and the process materials used, unknown risks can arise!

If the system

- Demonstrates visible damage
- Is not working in the framework of the specifications
- Was not stored properly
- Was subjected to extreme, improper transport conditions

If one of these points is relevant, then

- Take the system out of operation!
- Secure it against unauthorised or unintentional commissioning!
- Contact **MBRAUN** Service.

All malfunctions must be reported to the internal service department or the **MBRAUN** Service Department immediately!

Malfunctions must be documented in the service book

6.10.2 Eliminating faults

The elimination of faults – with cancellation and power failure routines - is described in Chapter 11.

The circuit diagram describes the basic principles for searching for faults in the electrical system (Chap. 13).

6.10.3 Behavior in case of emergency

Prerequisites:

Behavior in case of fire in the room depends on the process materials used and the conditions on-site. Therefore, the operator must create an emergency plan according to the specific circumstances and regulate these in a standard flow plan (see chap. Installation). This plan must be displayed in a visible place in the operating area. The personnel must be instructed about behavior in case of emergency and trained regularly.

- ▶ The operator of the system is obligated to familiarise him/herself with the flows in case of emergency.

6.10.3.1 Oxygen concentration in the room air drops



WARNING

Risk of suffocation in rooms with oxygen content < 19.5%

- ▶ Only enter room with compressed air bottle-driven breathing protection!

Troubleshooting:

- ▶ By responsible specially-trained person
- ▶ In case of questions, contact **MBRAUN** Service.



Recommendation

Use a wearable personal oxygen warning device that warns you if there is a critical lack of oxygen concentration in the ambient air.

- ▶ Ask **MBRAUN** Service.

If the oxygen content in the room air sinks below < 19.5%:

- ▶ Trigger and alarm / warn your colleagues
- ▶ Inform the operation's safety officer

In case of gas supply faults:

- ▶ Interrupt the gas feed: close the main input valve

In case of faults in the exhaust air system:

- ▶ Interrupt the gas supply
- ▶ Interrupt the circulation
- ▶ Leave the room immediately

Damage to the system –in case of emergency

6.10.3.2 Electrical accidents

In case of risks to people due to electrical malfunctions:

- ▶ Switch off main switch on the control cabinet!
- ▶ Inform the emergency services
- ▶ Secure system against unauthorised or unintentional commissioning

- ▶ All malfunctions must be reported to the internal service department or the **MBRAUN** Service Department immediately!
- ▶ Malfunctions must be documented in the service book

6.10.3.3 Escaping of process gases and materials

- ▶ Follow your standard flow plan (see Chap. 4.1 Preparation and installation).
- ▶ Perform a leak check and eliminate the error.
- ▶ In case of questions, contact **MBRAUN** Service.

6.10.3.4 Fire in the room

Behavior in case of fire in the room depends on the process materials used and the conditions on-site.

- ▶ Follow your operational standard operational plan (SOP) for the case of fire.(see Chap. 4.1 Preparation and installation).

6.11 De-installing the system – disposing of components

6.11.1 Disposal



DANGER

Risk of personal injury! Risk of environmental pollution!

If during disposal work, you must work with hazardous materials, heed the following:

- ▶ Wear personal protective equipment (PPE): appropriate breathing protection full mask (with suitable filter), protective gloves and eye protection!
- ▶ The user is responsible for heeding national and international regulations. He must adhere to health, safety and environmental guidelines!

The following components or materials mentioned can be contaminated with toxic substances and pollute the environment if they are not disposed of properly.

None of the following components and materials mentioned may be allowed to reach the environmental atmosphere, sewer system, bodies or water or the earth:

- Dispose of gas purifying system (with purifiers, vacuum pumps, blower), components of the system, and oil from the vacuum pumps according to the applicable local and national regulations.
- Box particle filter Dispose of used filters according to the locally-applicable national guidelines.
- Solvent filter (active carbon) The filter material of solvent filters (active carbon) can be contaminated by process chemicals and solvents. Heed the requirements from the safety data sheets (material data sheets). Dispose of the filter material according to the locally-applicable national guidelines.
- Exhaust Discharge all exhaust gases via an appropriate exhaust gas disposal system!

It is the sole responsibility of the operator during the disposal of contaminated material to prevent any environmental pollution.

Procedure for de-commissioning: *See Chap. 12*



6 A.1 Particularities in ECO-Mode operation	2
6 A.1.1 <i>Box light</i>	2
6 A.1.2 <i>Circulation operation and blower.....</i>	2
6 A.1.3 <i>Regeneration operation and vacuum pump (VPG)</i>	3
6 A.1.4 <i>Antechambers and vacuum pump (VP1).....</i>	4
6 A.2 Safety	5
6 A.2.1 <i>Intended Use.....</i>	5
6 A.2.2 <i>Misuse.....</i>	5
6 A.3 Controller	6
6 A.3.1 <i>Controller: Navigation overview.....</i>	6
6 A.4 Parameter	7
6 A.4.1 <i>Automatic</i>	7
6 A.4.2 <i>Blower</i>	8
6 A.4.3 <i>Box pressure regulation via blower</i>	9
6 A.4.4 <i>Vacuum pump gas purifier (VPG + VPGL).....</i>	10
6 A.4.5 <i>Vacuum pump antechamber (VP1+2)</i>	10
6 A.4.6 <i>Box light</i>	11
6 A.5 Activate/deactivate ECO-Mode.....	11

Particularities in ECO-Mode operation

6 A Eco-Mode

6 A.1 Particularities in ECO-Mode operation

ECO-Mode provides an energy-saving operating mode that can be set for inactive operation overnight or on the weekend.

The ECO-Mode function can also be activated automatically at a defined point in time (e.g. daily at 5:00pm).

With activated ECO operating mode, the lowering of the box pressure with exceeding of the upper operating limit does not happen due to pumping out with the help of the vacuum pump, but rather by opening the additional valve (VDA), which is installed directly on the gas output of the blower. This regulation allows operation of the box only in over pressure. At the start the lower operating limit is set to + 2 mbar and the upper operating limit is adapted accordingly.

When ECO-Mode is deactivated, the original operating limits of the box pressure are reactivated.

As needed, the blower can work at reduced frequency, the vacuum pump and box light can be switched off automatically.

The minimum circulation should not drop below 10x the volume change of the enclosed box volume since otherwise there can be a loss of the quality of the box atmosphere.

Note: Initially please follow the descriptions of operation in normal operation - see Chapters 5 to 9.

6 A.1.1 Box light

The box light can be switched ON and OFF manually while in ECO-Mode (→ function keys screen)

6 A.1.2 Circulation operation and blower

The energy savings is achieved through a reduction of the frequency of the speed of the blower and through switching off the vacuum pump(s).

Pressure regulation

The pressure regulation takes place during the circulation in ECO-Mode via an additional output valve (VDA) on the blower output.

In ECO-Mode, the operating limits are adapted automatically in a range between $\geq + 2$ mbar (lower operating limit) and $\geq + 3$ mbar (upper operating limit) with a difference of at least 1 mbar.

As soon as ECO-Mode is deactivated, the previously-set operating limits are automatically reactivated.

Oxygen and moisture content

If the oxygen or moisture content in the box exceeds an adjustable limit value (*pre-set: 10 ppm*), the speed of the blower is increased to the normal speed. If the H₂O and O₂ concentrations drop ≤ 1 ppm, the blower switches back to the speed of the ECO-Mode.

6 A.1.3 Regeneration operation and vacuum pump (VPG)

Regeneration operation can also be performed with activated ECO-Mode: the vacuum pump (VPG) is ready for the regeneration program.

Case 1:

> ECO-Mode is activated > Parameter "automatic switch-off of the vacuum pump" - "Yes" is set

When the regeneration program starts, the vacuum pump (in step 2) is switched ON. After completing the regeneration program (step 17), the pump is switched OFF again. Manual switching off of the vacuum pump during regeneration is not possible (*see Chap. 7.3.2.3 Basic principles of the regeneration program*).

Case 2:

> Parameter "automatic switch-off of the vacuum pump" - "Yes" > ECO-Mode is switched on after the regeneration has started

When the regeneration program is completed, the vacuum pump (in step 17) remains switched ON.

Particularities in ECO-Mode operation

6 A.1.4 Antechambers and vacuum pump (VP1)

Prerequisite

- > ECO-Mode is switched on and

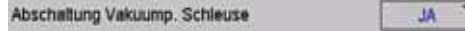
ECO-Mode parameters

- > If one or several manually-operated antechambers are connected to the vacuum pump in question:

Manually-operated antechambers
 (without electrical valves or sensors)

These vacuum pumps are only switched off once when activating the ECO-Mode.

Note: The PLC does not receive any information about whether and when these antechambers were evacuated. Therefore, there can be no automatic switching off of the connected vacuum pump after an evacuation cycle!

- > Only automatic antechambers are present – main antechamber and mini-antechamber / - - (insofar as present):

Automatic antechambers

With activation of ECO-Mode:

- The vacuum pump VPG is switched OFF.

If an automatic antechamber cycle starts:

- The vacuum pump is switched ON and
 - After 30 minutes switched OFF if no antechamber cycle is active.
-

6 A.2 Safety

6 A.2.1 Intended Use

Operation in ECO-mode allows energy-saving operation of the inert gas system in stand-by operation.

6 A.2.2 Misuse

If the upper operating limit of the system is set to a value < 0 mbar and the box should be kept at under pressure, the ECO-Mode may not be switched on.

Controller

6 A.3 Controller

6 A.3.1 Controller: Navigation overview

Start screen:

01102-0

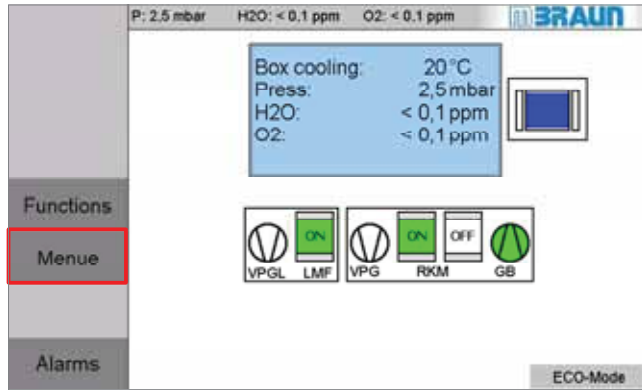

With activated ECO-Mode, there is an indicator on the start screen (bottom right)

Calling the ECO-Mode parameters screen

► Touch **Menu** button

Menu Screen Selection

01120

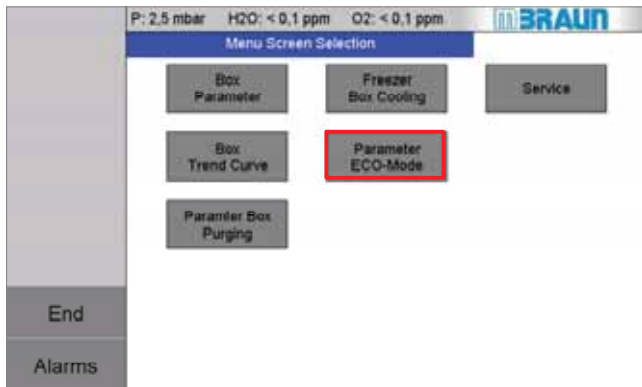

On the "Menu Screen Selection":

► Touch **Parameter ECO-Mode** button

ECO-Mode parameters

01121

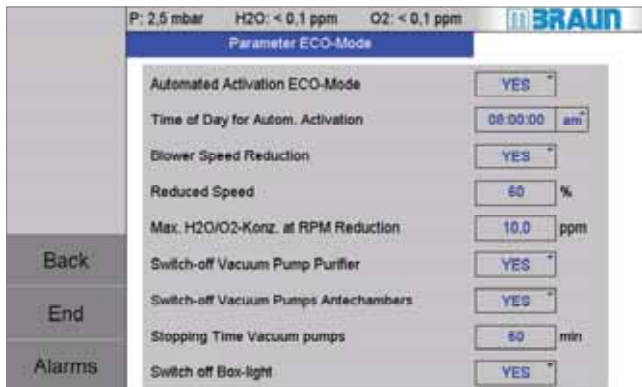

See below for description

6 A.4 Parameter

ECO-Mode parameters

01121

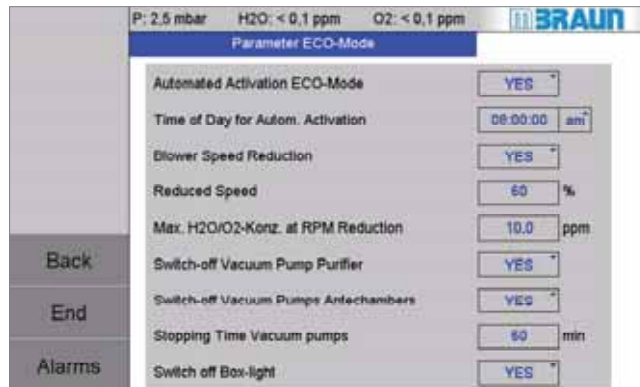

The manufacturer delivers the system with the following settings:

(see Chap. 5.6 Basic parameters)

6 A.4.1 Automatic

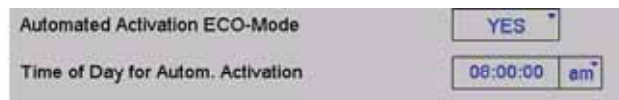

Automatic

With activated ECO-Mode:

Prerequisite

- > Automatic activation is activated (Yes)
- ▶ Enter standard time specification for automatic switching on

Note:

The weekdays are not taken into consideration since ECO-Mode remains activated until it is manually deactivated. Therefore the system remains in ECO-Mode on Sundays, for example.

 Parameter

6 A.4.2 Blower

Blower Speed Reduction	YES
Reduced Speed	60 %

ECO-Mode parameters

- ▶ Reduced speed

Prerequisite

> ECO-Mode is switched on

Reduction of the blower speed:

- ▶ Enter value of the reduced speed → Input range: 60 -100 %

Blower Speed Reduction:	Yes	Speed is reduced
	No	Do not reduce speed

Max. H ₂ O/O ₂ -Konz. at RPM Reduction	10,0 ppm
--	----------

Parameter

Increase speed to 100%
with adjustable limit value O₂
and H₂O content

Pre-set by **MBRAUN**:

10 ppm for O₂ and H₂O:

*The limit values must be set
so they are equally high*

Please note:

Limit value O₂ and H₂O is less than < limit value for the
activation of the automatic box purging!

6 A.4.3 Box pressure regulation via blower

The value of the lower operating limit is limited to $\geq +2$ mbar,

The value of the upper operating limit remains unchanged if it is set to $\geq +3$ mbar; otherwise it is set to 3 mbar. (See 6 A.1.2).

Explanation of regulation via VDA / VPA – see also specification for ECO-Mode

Box pressure parameters

01500-2

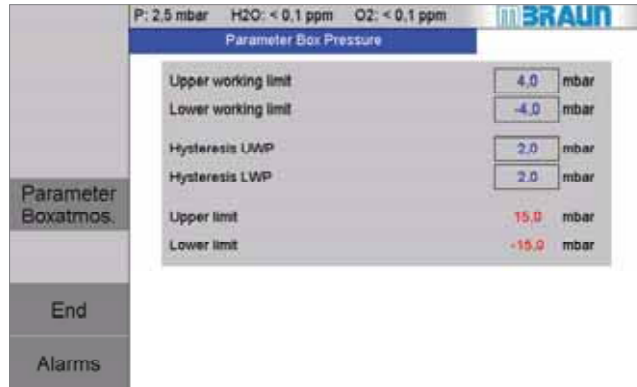

Setting operating limits

Blower speed in normal operation and in ECO-Mode

		Normal operation	Eco-Mode	
Blower type			Gas purifier without LMF	Gas purifier with LMF *)
BL01	Speed	100%	60 - 100%	80 - 100 %
	Frequency	50 Hz	30 Hz – 50 Hz	40 Hz – 50 Hz

***) For work with release of gaseous contamination:**

Recommendation: ECO-Mode should not be activated.

! The blower speed of 100% constantly ensures that gas contamination is removed from the box atmosphere as quickly as possible.

*) See also Chapter 7, Parameters: Blower speed in normal operation

 Parameter

 6 A.4.4 Vacuum pump gas purifier (VPG + VPGL)

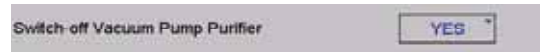

ECO-Mode parameters

- Vacuum pumps
- Gas purifier

Prerequisite

- > ECO-Mode is switched on
- > Automatic switch-off... Yes

VPG / VPGL (Gas purifier RKM + LMF)

- Automatic switch-off of the VPG (and if necessary of the VPGL).

With activation of a regeneration (RKM or LMF), the required pump is switched on automatically and switched off again after completing the regeneration.

see also 6 A.4.3

Note:

The box pressure regulation is accomplished via the additional gas output valve.

 6 A.4.5 Vacuum pump antechamber (VP1+2)

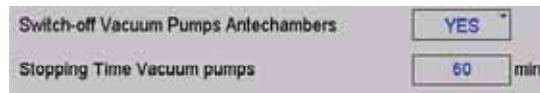

ECO-Mode parameters

- Vacuum pump
- Antechambers

VP1 (Separate pump antechamber)

If the antechamber is equipped with a separate vacuum pump: the vacuum pump is switched off 60 minutes after the last evacuation of the antechamber.

Time can be set from 30..600 min.

see also 6 A.4

Only manually-operated antechambers (without electrical valves or sensors):

Note

The PLC does not receive any information about whether and when these antechambers are evacuated. Therefore, there can be no automatic switching off of the connected vacuum pump after an evacuation cycle!

Manually-operated antechambers

see also 6 A.4

These vacuum pumps are only switched off once when activating the ECO-Mode.

To execute an antechamber cycle (loading), the vacuum pump can be switched on manually on the touch panel using the function key on the function screen and then switched off again if needed.

6 A.4.6 Box light



ECO-Mode parameters

- Box light

Prerequisite

- > ECO-Mode is switched on
- > Automatic switch-off box light is activated

see also 6 A.4

6 A.5 Activate/deactivate ECO-Mode

Functions screen

01160-1

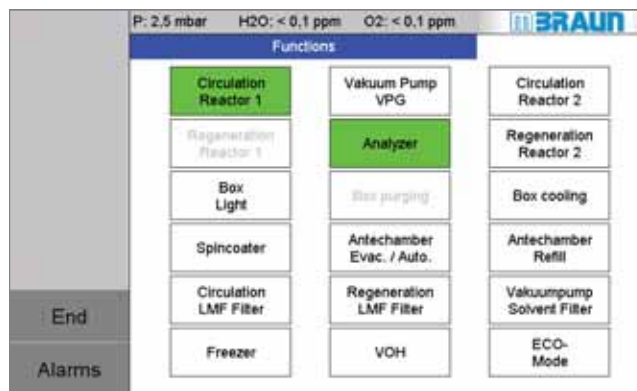

To activate/deactivate

- ▶ Touch **ECO-Mode** button

The colour changes from WHITE to GREEN

Manual activation

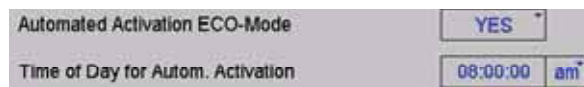
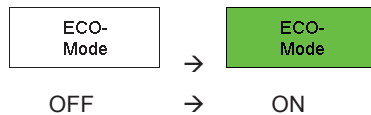

Automatic activation of the ECO-Mode at a particular point in time:

Prerequisite

- > the parameter is set to "Yes"

! If ECO-Mode is activated, it remains switched on until it is switched off again manually. This ensures that the system remains in energy-saving mode, for example on holidays/weekends.

Activate/deactivate ECO-Mode

7.1	Introduction	7-2
7.1.1	<i>Basic rules for the safe operation of the system.....</i>	7-2
7.1.2	<i>Use of a vacuum pump for several system components.....</i>	7-2
7.2	Safety Gas purifier	7-3
7.2.1	<i>Ambient air.....</i>	7-3
7.2.2	<i>H₂ mixture for regenerating H₂O and O₂ reactors.....</i>	7-3
7.2.3	<i>Solvents – solvent filter (LMF).....</i>	7-4
7.3	Gas purifier (O₂ and H₂O).....	7-5
7.3.1	<i>Gas purifier controller RKM – Navigation overview.....</i>	7-5
7.3.2	<i>Gas purifier operation (RKM for H₂O + O₂).....</i>	7-11
7.4	Gas Purifier Solvents (LMF)	7-25
7.4.1	<i>Technical Data</i>	7-25
7.4.2	<i>Safety.....</i>	7-25
7.4.3	<i>Manual valve controlled solvent filter LMF.....</i>	7-26
7.4.4	<i>PLC-controlled, regenerative solvent filter LMF.....</i>	7-27
7.4.5	<i>Solvent sensor (Option).....</i>	7-31

Introduction

7 Operation of gas purifier

7.1 Introduction

This chapter shows the operation of the following functions:

- Gas purifier for the removal of oxygen and moisture (O₂ and H₂O)
- Solvent filter (LMF)

The operating modes "Circulation" and "Regeneration" are described.

Functions for the gas and pressure management within the box are described in Chap. 8 Inert gas box.

7.1.1 Basic rules for the safe operation of the system

- ▶ Always note that the connections/screw connections are made correctly (*according to Chap. 4 Installation and Chap. 6 Commissioning and principles of operation*).
- ▶ Maintain the operating flows according to this operating manual:
 - Switch on the circulation only after purging of the box (*see Chap. 8, Inert gas box*).
 - The intervals for the regeneration of the reactors depend on the processes used. Determine the time at which a regeneration of your system's reactors is required.
 - Do not wait with the regeneration of the reactors until they are completely saturated.
 - After each regeneration, empty the container with the regeneration condensate
- ▶ PLC: adhere to permissible parameter ranges The functions of the gas purifying system are defined and controlled by the parameters of the PLC.

In case of equipment with a pressure control valve in the gas purifier (optional):

- ▶ Perform the function test for the pressure control valve regularly

7.1.2 Use of a vacuum pump for several system components

Please note:

The quality of the regeneration processes is compromised with a lot of antechamber activity.

→ Box pressure regulation and antechamber processes take precedence.

→ During regeneration, evacuation steps of the regeneration process running in parallel will be interrupted – however the step time is not increased

MBRAUN recommends using an additional vacuum pump if antechamber cycles are performed very frequently and the regeneration cannot be performed during work-free time (overnight).

7.2 Safety Gas purifier

! Heed the basic safety instructions in the basic safety chapter!

7.2.1 Ambient air

NOTICE

Damage to the reactors due to oxygen and moisture in the ambient air! Operation in ambient air can cause overheating of the reactor material and destruction of the valves.

If the O₂ share in the box is greater than 100 ppm:

Before switching the reactor into circulation operation:

- ▶ Purge box with inert gas from external source until there is an O₂ level in the box atmosphere of less than 100 ppm
-

7.2.2 H₂ mixture for regenerating H₂O and O₂ reactors

For the process of regenerating the reactors (RKM), a H₂ gas mixture of 3-10% is used. The upper absolutely must not be exceeded!

NOTICE

Exceeding the hydrogen concentration >10% causes overheating of the reactor during regeneration!

- ▶ Be sure to adhere to the specified hydrogen concentration of 3-10%!
 - ▶ Follow the details in the Installation chapter.
-

! **Exception LMF**

No hydrogen mixture may be used for the regeneration of the solvent filter! (*See below*)

Gas purifier (O₂ and H₂O)

7.2.3 Solvents – solvent filter (LMF)

If solvents are used as process materials in the inert gas box, it is the customer's responsibility to perform a hazard estimation/risk analysis and to specify behaviour in the handling of process material as well as in case of risk under the specific conditions on-site in a standard operating manual.

Follow the instructions in the basic safety chapter (Chap. 3).



DANGER

Health hazard and risk of injury due to self-ignition / explosion!

During enriching of solvents in the box / in the exhaust, if (in case of error) O₂ penetrates the system!

- ▶ With the use of solvents in the box: always switch solvent filter and gas purifier RKM on in parallel!
- ▶ Discharge all vacuum pump exhaust as well as used regeneration gas via the user's exhaust discharge system.

With use of a regenerative solvent filter (LMF):

- ▶ Connect the exhaust to an explosion-proof in-house exhaust system!

In case of questions, please contact **MBRAUN** Service.



WARNING

Saturated solvent filters cause an increase of the solvent content in the box. This causes material damage (to O-rings, copper pipes, O₂-/H₂O reactors, etc.)

Thus the leak-tightness and functionality of the inert gas box system are no longer a given! There are consequent risks / health hazards depending on the degree of hazard of the processes/process materials used!

Always ensure that the capacity of the solvent filter is sufficient for the circulation operation:

- ▶ For LMF (absorption principle): Replace before the saturation of the filter medium
 - ▶ Regenerative LMF: Regenerate the LMF in periodic time distances.
 - ▶ If necessary, use additional solvent sensors for the monitoring of the box atmosphere and detection of filter saturation.
 - ▶ In case of questions, please contact **MBRAUN** Service.
-



1 kg active carbon absorbs approx. 100 g organic solvents. The precise quantity fluctuates depending on the solvents used and the ambient temperature.

MBRAUN offers sensors that measure the content of the solvent in the gas after it exits the filter. This way, saturation of the solvent filter can be detected early on.

7.3 Gas purifier (O₂ and H₂O)

7.3.1 Gas purifier controller RKM – Navigation overview

Start screen:

01103-1

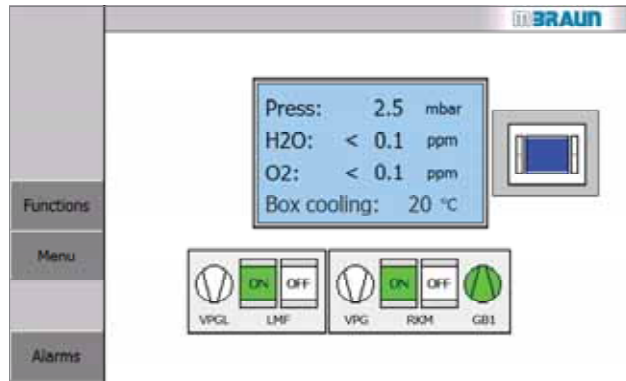

Touch the symbol key RKM on the start screen

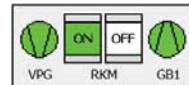

(here: example: 2-RKM-System)

Gas purifier screen 1 reactor:

01310-2

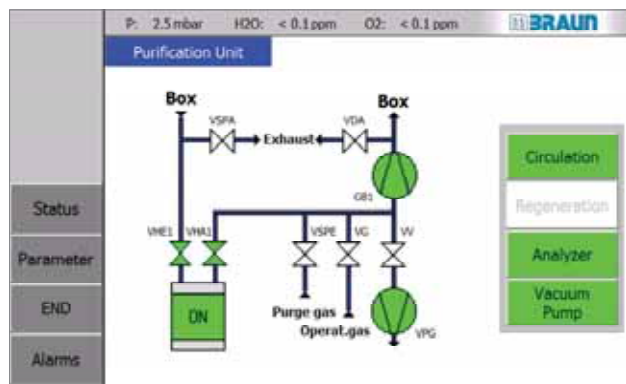

1-reactor system

Gas purifier screen 2 reactors

01321

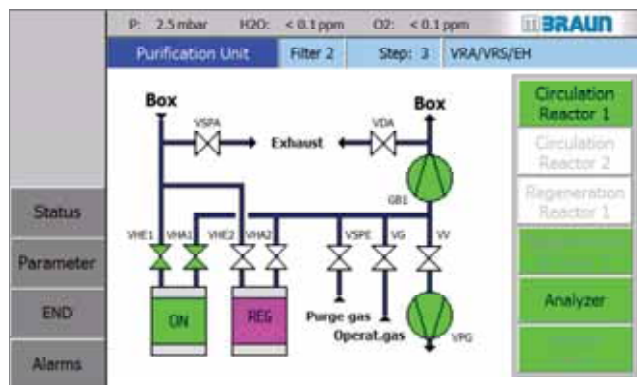

2-reactor system

Gas purifier (O₂ and H₂O)

On the gas purifier screen:



Navigate to the "Parameter" or "Status" screen

Navigation button

- ▶ Touch **Parameter** or
- ▶ Touch **Status**

Purification Unit Parameter screen

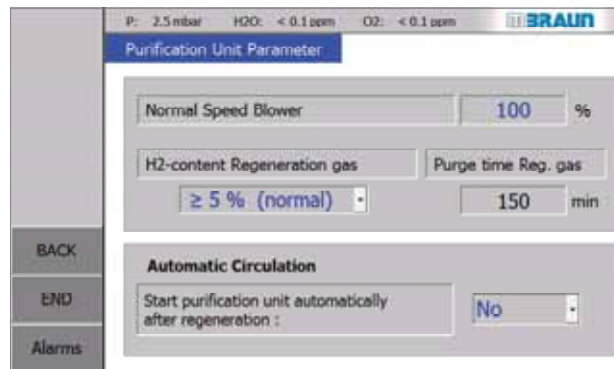

01300-1

Parameter button

- ▶ Call up Purification Unit Parameter screen

Purification Unit Parameter + Status screen

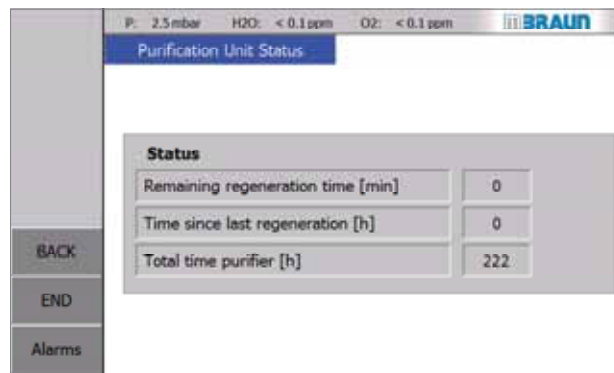

01311

Status button

- ▶ Call up Purification Unit Parameter + Status screen

7.3.1.1 Purification Unit screen

This screen indicates the function status of the gas purifier.

Purification Unit screen:

01321

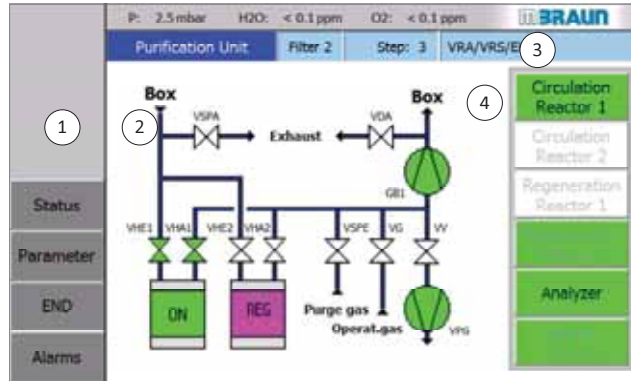

- (1) Bar with navigation buttons
- (2) Scheme of the gas purifier
- (3) Status line regeneration
- (4) Operator panel with function keys / Display and selection (see Operation 7.5.3)

In this example of a gas purifier with 2 reactors, the circulation operation is running via reactor 1 (ON = Green) while reactor 2 (REG = Magenta is in step 6 of the regeneration).

Example

see 7.3.2.3

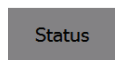

- calls up the "Purification Unit Status" screen

- (1) Navigation

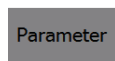

- calls up the "Purification Unit Parameters" screen

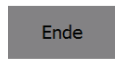

- back to the "Start screen"

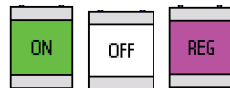

Display status indicator

- (2) Schematic drawing of the gas purifier with valve status and status of the components.



VPG / GB Display status vacuum pump (VPG) / blower (GB)

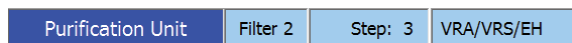

- (3) Status line regeneration

Indicates the current step of regeneration; if regeneration not active: indicator "Regeneration off" see also 7.3.4.2

(4) next page

Gas purifier (O2 and H2O)

(4) Operator panel with function keys:

Display and selection

On the "Purification Unit" screen it is possible to activate/deactivate functions (alternative: via the "Functions" screen – see Chap. 5.3.4)

Circulation Reactor 1	Switch "Circulation" function on/off;	see 7.3.2.1
Circulation Reactor 2		
Regeneration Reactor 1	- Switch "Regeneration" function on/off;	see 7.3.2.3
Regeneration Reactor 2		
Analyzer	- Switch analyzer on/off;	see 8.4
Vacuum Pump	- Switch vacuum pump on/off	Display of the status

7.3.1.2 Purification Unit Parameters

The screen shows the parameters for the automatic start of regeneration operation of the reactors.

Purification Unit Parameter screen

01300-1

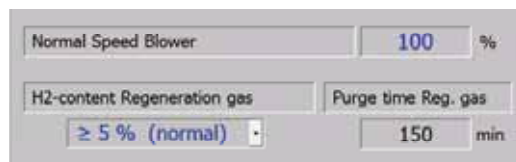
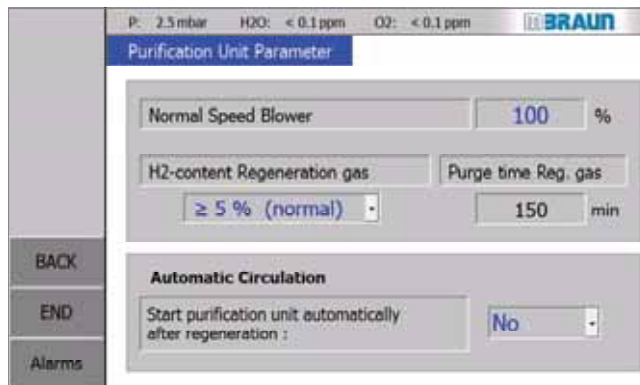

Circulation Blower Speed

Variable regeneration time

1. Circulation Blower Speed:

The speed of the blower can be pre-selected for normal circulation operation in the range between 60 .. and 100 % (corresponds to 30 .. 50 Hz). Default: 100 %

2. Variable regeneration time:

Depending on the percentage of the H₂ regeneration gas, the regeneration times can be set variably. The specification of the regeneration duration refers to the step "n" "Purging with regenerative gas" (here: values for MB20/200):

Purging with regeneration gas

Share of the H ₂ share in the regeneration gas ≥ 5 % (Standard)	Duration step "n" 150 min *)
Share of the H ₂ share in the regeneration gas < 5 %	Duration step "n" 300 min *)

*) The numeric values for the regeneration duration are generated by the system.

Total duration of regeneration cycle

with H₂ share in the regeneration gas ≥ 5 % Duration approx. 960 min (16 h)

with H₂ share in the regeneration gas ≤ 5% Duration approx. 1110 min (18.5 h)

3. Automatic circulation/regeneration

For systems with 1 RKM, the automatic circulation can be set: after regeneration, the circulation operation is started automatically.



Automatic circulation

(only 1-RKM system)

For system with 2 RKMs, the automatic regeneration can be set: After a defined interval, the regeneration operation for one RKM unit starts.



Automatic Regeneration

(only 2-RKM system)

Gas purifier (O₂ and H₂O)

7.3.1.3 Purification Unit Status

Time status of the gas purifier

The Purification Unit Status screen indicates

- Remaining regeneration time
- Time since last regeneration
- Total hours of operation of a reactor since initial commissioning

Purification Unit Status

01322

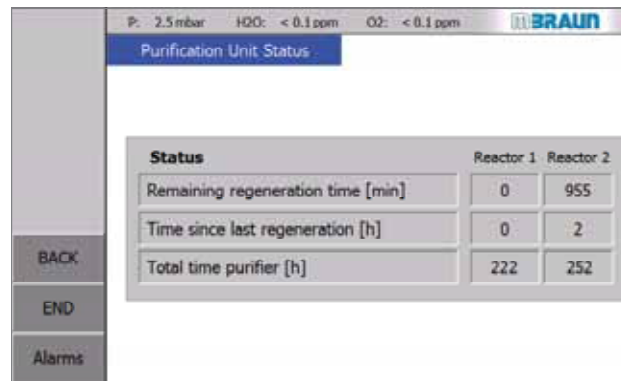

Status	Reactor 1	Reactor 2
Remaining regeneration time [min]	0	955
Time since last regeneration [h]	0	2
Total time purifier [h]	222	252

Example:

2 RKM system

(for 1 RKM only 1 column is displayed)

The time "since last regeneration" is reset automatically after regeneration.

Process status

Purification Unit screen

01321

Purification Unit	Filter 2	Step: 3	VRA/VRS/EH
-------------------	----------	---------	------------

Indicates the current step of regeneration; if regeneration not active: indicator "Regeneration off"

The program steps regenerate are shown in Chap. 7.3.7.

7.3.2 Gas purifier operation (RKM for H₂O + O₂)

The two operating modes circulation and regeneration are described here.

Circulation operation

The gas purification by the reactors takes place in the PLC-controlled operating mode "Circulation operation":

- through manual activation/deactivation
- through automatic activation after regeneration of a reactor

Regeneration

The regeneration of the reactors is required at regular intervals. The intervals vary depending on the type and intensity of the process materials used (see below).

The flows of the circulation operation and of regeneration can

- occur one after another (1-RKM system)
- be executed in parallel (2-RKM system).

Gas purifier (O₂ and H₂O)

7.3.2.1 Circulation operation - activate/deactivate manually

Prerequisites:

- > the box is pre-purged (O₂ content < 100 ppm)
- > regeneration operation has run completely through and
- > the "Circulation" function is released

Functions 1 screen

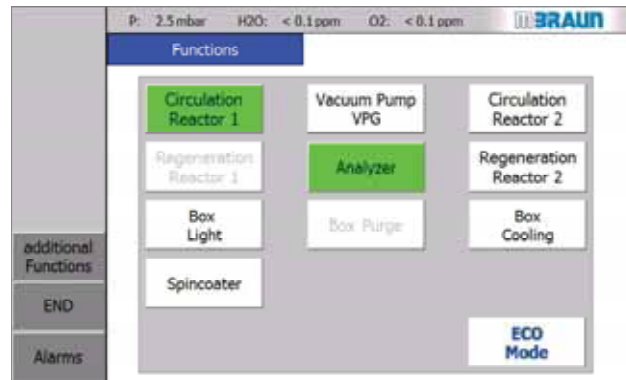

01160-1

Activating circulation manually

either on Functions 1 screen

Purification Unit screen

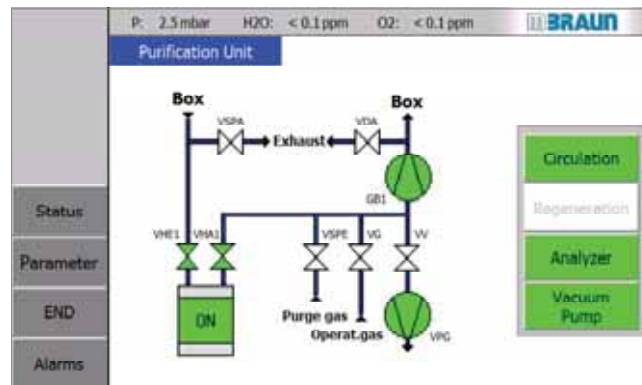

01310-2

or on the Purification Unit screen:

The colour of the function key and the reactor symbol changes from WHITE → to GREEN



RKM icon (on the Purifier Unit screen): change from OFF to ON

Switching on the circulation function

- ▶ Touch button Circulation

Purification Unit screen (with 1 reactor):

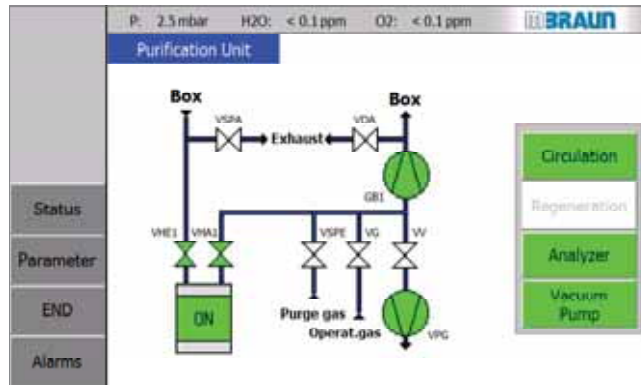

01310-2

Circulation in the 1-reactor system

Status:

In circulation operation, the blower and the vacuum pump are switched on and the VHE and VHA valves are open:

Functions:

The box atmosphere circulates from the box to the reactor, is cleaned of H2O and O2 and fed back into the box.

Purification Unit screen (with 2 reactors)

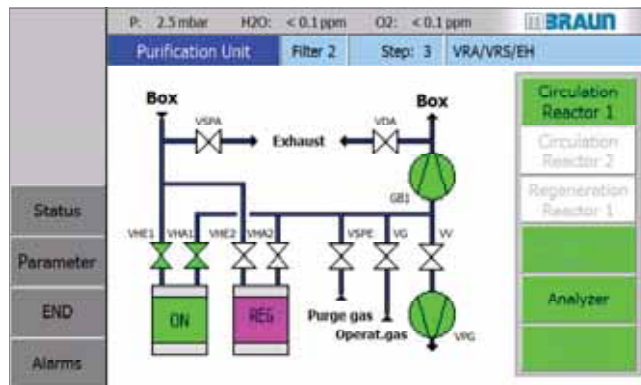

01321

Circulation in the 2-reactor system

Status reactor 1:

Circulation operation takes place via the reactor RKM 1

→ the function Regenerate reactor 1 is blocked.

Status reactor 2 – parallel:

Reactor 2 is regenerated.

→ Valves VHE2 and VHA2 are closed. (see 7.3.5.2)

Gas purifier (O2 and H2O)

Functions 1 screen:

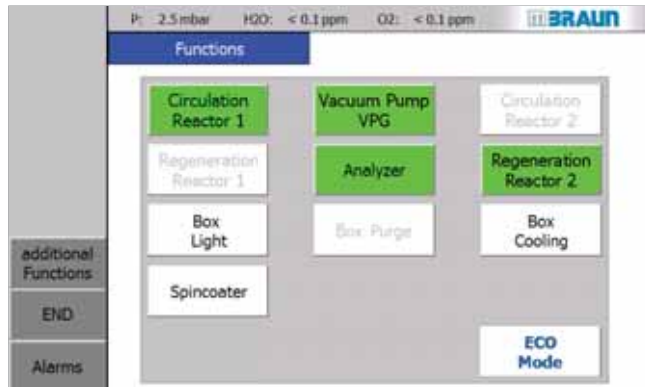

01160-3

During circulation:

Blocked functions:

Reactor 1 is in circulation operation:

- the function "Regeneration" is blocked:
- the function "Box Purge" is blocked

A release of the functions occurs after switching off the "Circulation" function.

Switching off the "Circulation" function:

- ▶ Touch Circulation Reactor 1
- Circulation function is switched OFF
- ⇒ Release of the functions for Reactor 1:
 - "Regeneration" - "Circulation"
 - as well as function - "Purge box"

The colour of the function key changes from GREEN → to WHITE



RKM icon (on the Purifier Unit screen): changes from ON → to OFF

The regeneration operation function is released for Reactor 1:

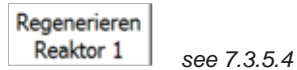

see 7.3.5.4

Starting regeneration reactor 1:

- ▶ Touch Regeneration Reactor 1

Circulation operation can now be done via Reactor 2

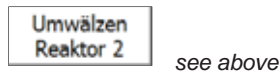

see above

Starting circulation reactor 2:

- ▶ Touch Circulation Reactor 2
- ▶ Or: regenerate reactor

7.3.2.2 Circulation operation – activate automatically

Parameters can be set for the automatic switching on of the circulation after completion of a regeneration process:

Purification Unit Parameter screen

01300-1

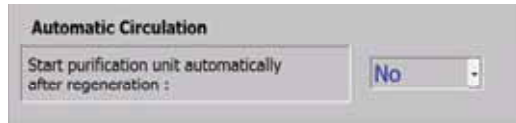

Activating automatic circulation:

- ▶ select "Yes" from the pull-down menu

Deactivating automatic circulation:

- ▶ select "No" from the pull-down menu



For systems with a single reactor:

MBRAUN recommends switching on the automatic circulation.

7.3.2.3 Regeneration operation - basic principles

Regeneration cycle

If the cleaning capacity of the reactor charging of the gas purifier declines, the oxygen and moisture concentration in the box atmosphere increases. The reactors must be regenerated according to the process-specific experiential values: the intervals between the regeneration cycles vary depending on the system, type of usage and time.

See Chap. 6.5.2 – Commissioning – operating modes or here



MBRAUN recommends regenerating the reactor at regular intervals and not waiting until a clear breakdown of the cleaning power can be detected.



Do not perform any antechamber cycles during regeneration

For manually-operated antechambers, the execution of an antechamber cycles during the evacuation step of the regeneration programme should be avoided if possible.

MBRAUN recommends starting the regeneration of a reactor at the end of the work day and letting it run overnight.

Gas purifier (O₂ and H₂O)**Prerequisites:**

- > Before the start of the regeneration programme, make absolutely sure that there is sufficient regeneration gas available.

A regeneration programs needs for

MB20 / MB200: approx. 3.5 m³ regeneration gas

Using a standard gas bottle (50l): min. pressure: 80 bar (8 MPa)

Flow: programme steps for regeneration

The following table shows the individual steps of the regeneration programme, which are run through automatically after activation of the regeneration operation.

Step		Time	Valve status open*)	Action – STD
0	↓	Start 0 min		Regeneration deactivated
1			VRA/ VRS/ VRE	Test regeneration gas ON
2				Test regeneration gas OFF
3	↓		VRA/ VRS/ EH	Flow of regeneration in various steps
[4... 7]				
8	↓		VRA/ VGB/ VRV	
[9... 16]				
17	↓	Stop after e.g. 960 min		Regeneration complete

*) Valve designations:

VGB	Blower valve
VRE	Regeneration input valve
VRA	Regeneration output valve
VRS	Regenerate valve – purge output
VRV	Regenerate valve – vacuum
EH	Heating
VS	Valve reactor refilling

- ! In case of a power failure, the regeneration process is interrupted and - depending on the step - repeated or continued. This can require additional quantities of regeneration gas. See Chap. 12 Troubleshooting.

Conditions for regeneration in 1-reactor and 2-reactor systems

! 1-reactor system (SP)

A reactor in circulation operation is blocked for the function "regeneration": After the function "Circulation" is switched OFF → Regeneration function is released

2-reactor system (DP):

Only one reactor at a time can be regenerated. Circulation operation can now be done via the other reactor.

7.3.2.4 Activating regeneration manually

Functions 1 screen (DP)

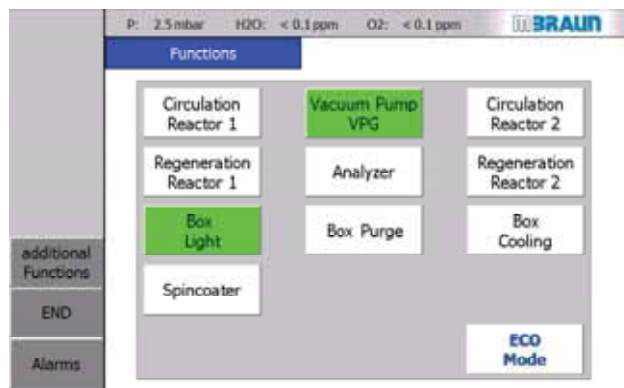

01160-4

Activating regeneration manually:

on Functions 1 screen
or Purification Unit screen:

- ▶ Touch Regeneration Reactor 1
- or Regeneration Reactor 2

Purification Unit screen

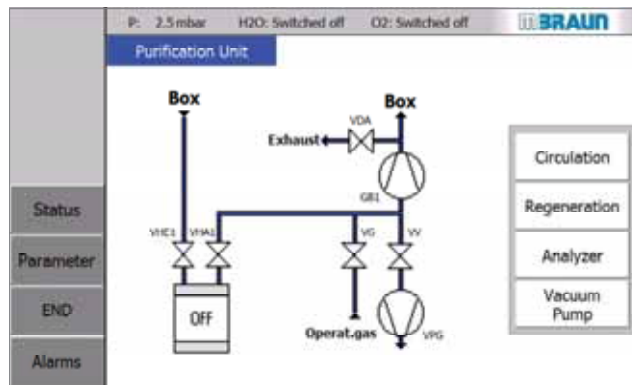

01310-1

Example: 1-reactor system:

On the gas purifier screen:

- ▶ Touch: Regeneration

→ Queries are shown:

Gas purifier (O₂ and H₂O)

Query 1 on the Purifier Unit screen:

01310-1 – query 1

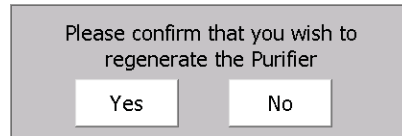
▶ Selection **Yes**

→ The colour of the function key changes from WHITE → to GREEN

→ Status changes:



from OFF to REG

On the screen Purifier Unit

Display of

→ State of functions

→ and query 2

Query 2 on the Purifier Unit screen:

01310-2 – query 2



→ Abort button

→ The acknowledge button for testing the regeneration gas through-flow is displayed:



Flow regulator

▶ Set secondary pressure on the regulator until flow-meter indicates a gas flow between 15 and 20 l/min.

Step 1:▶ Check preconditions:
> is the float of the flow regulator okay?

If the gas flow is okay:

▶ confirm this button
→ After confirmation, the regeneration program starts*Examples of regeneration processes see below, page 20 / 21***Abort of pre-selected function regeneration**

Query 1 on the Purifier Unit screen:

01310-1 – query 1

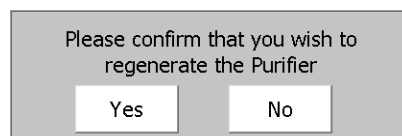
▶ Selection **No**

→ back to screen Purifier Unit

Abort during regeneration process

Gas purifier screen - 1 reactor

01310-4

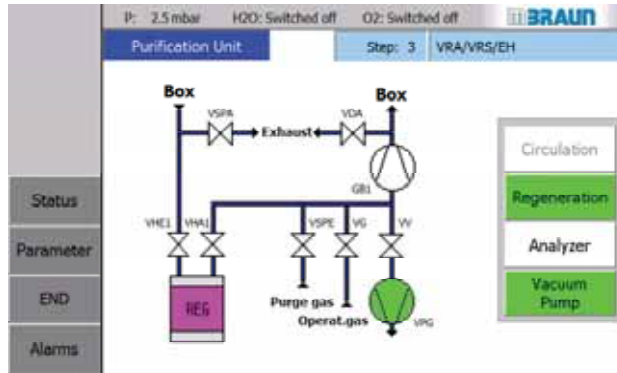

Note: Abort of a regeneration process: Only during step 1-3; after step 3 is finished, the button **Regeneration** is locked (=grey types).

- ▶ Touch the green button **Regeneration**
- The button **Abort** is shown:



Abort:

- ▶ touch button **Abort**
- Question of query 3 is shown:

Query 3 on the Purifier Unit screen:

01310-3 – query 3

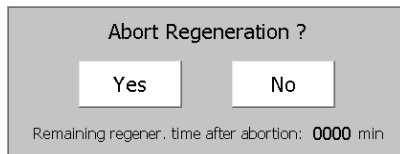

Display: Remaining regeneration time at cancel: in min.

Cancel regeneration:

- ▶ Touch test button **Yes**

Perform regeneration:

- ▶ Touch test button **No**

→ The regeneration programme is continued automatically

Gas purifier (O₂ and H₂O)

Regeneration examples: About the Purifier Unit screens – 1-reactor and 2-reactor systems

Display of process status

- The process status is displayed below the permanent line: here: Reactor 2 is in programme step 6.
- The display of the time status can be called up using the "Status" navigation button (see 7.3.4.1)

Gas purifier screen - 1 reactor

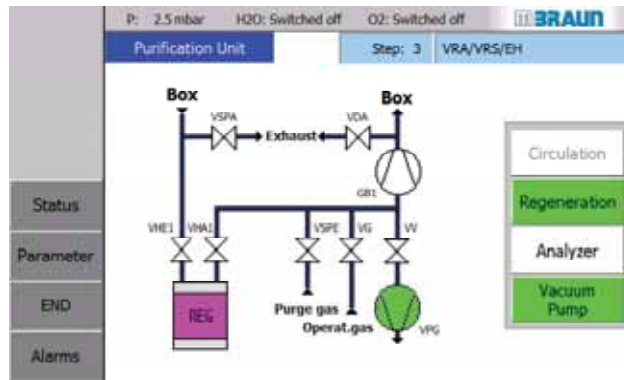

01310-4

Regeneration in the 1-reactor system

Status:

The "Regeneration" function is active

- The "Circulation" function is blocked until the end of the regeneration programme
- The measurement devices are switched off automatically

Gas purifier screen - 2 reactors

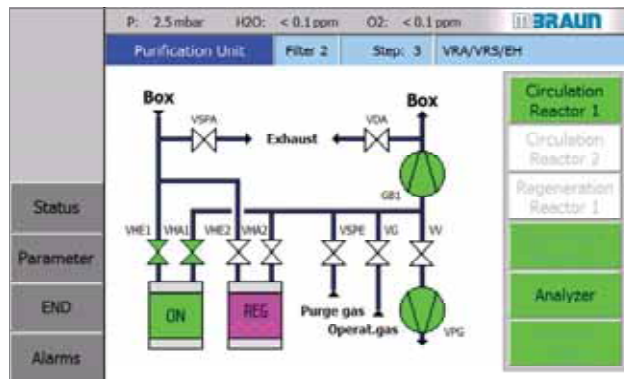

01321

Regeneration in the 2-reactor system

Status reactor 1:

Circulation operation takes place via reactor 1

- the function "Regenerate reactor 1" is blocked.

Status reactor 2:

- Valves VHE2 and VHA2 are closed.
- Reactor 2 is regenerated (see 7.3.5.2).

Example of regeneration: about the Functions screen - 2-reactor system

Functions 1 screen:

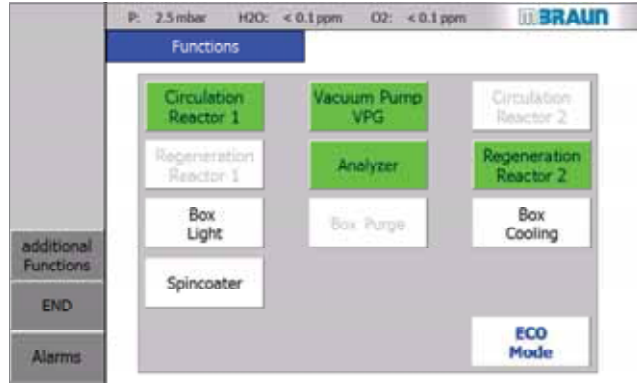

01160-3

Button status during regeneration

Status reactor 1:

Reactor 1 is in circulation operation:

→ the function "Regeneration" is blocked

Status reactor 2:

Reactor 2 is in regeneration operation:

→ the function "Circulation" is blocked

After completing the complete regeneration programme flow:

⇒ Release of the "Circulation" function

Blocked function "Purge box"

As long as one of the reactors is in circulation operation, the (optional) "Purge box" function is blocked.

Only if the circulation operation of both reactors is switched off is the "Purge box" function released. (cf. Chap. 8 Inert gas box).

Gas purifier (O₂ and H₂O)

7.3.2.5 Regeneration - activating automatically (only in 2-reactor systems)

Prerequisite

- > Constant stock of regeneration gas is available
- > Automatic regeneration is set (see 7.3.3 Parameters):

Purification Unit Parameter screen



01300-1

Setting automatic regeneration

After the defined regeneration interval, the regeneration programme for a reactor starts. Circulation operation is switched automatically to the other reactor unit.

7.3.2.6 Ending regeneration operation – change to circulation operation

1-reactor system:

Purification Unit screen

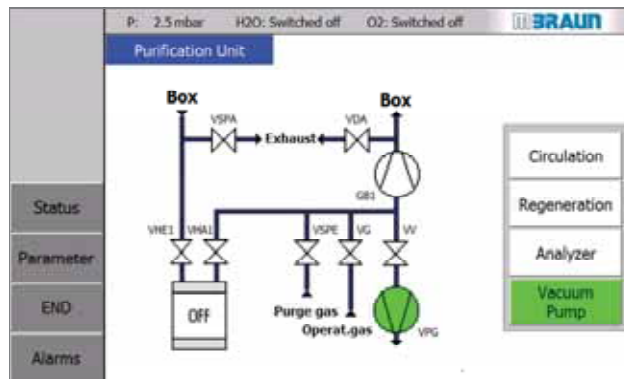

01310-5

Change to circulation operation**Status:**

→ Regeneration is complete

Display after flow of the regeneration cycle:

- The "Regeneration" status line is hidden
- The colour of the symbol of the active reactor changes from MAGENTA (active) to WHITE (inactive). → the function "Circulation" is ready
- The colour of the function key changes from GREEN (active) to WHITE (inactive)

! With equipment with ECO-Mode:

Please note the instructions for switching off the vacuum pump after regeneration: *Chap. 6 A. ECO-Mode*

Activating manually:

on the Purification Unit or Functions 1 screen –



see 7.3.5.1

Automatic circulation

If the automatic circulation is selected, operation changes automatically into circulation operation (see 7.3.5.2).

Change to circulation operation 1-reactor system

Activating manually:

- ▶ Touch [Circulation](#)

or

with *activated automatic mode*

2-reactor system

Purification Unit screen

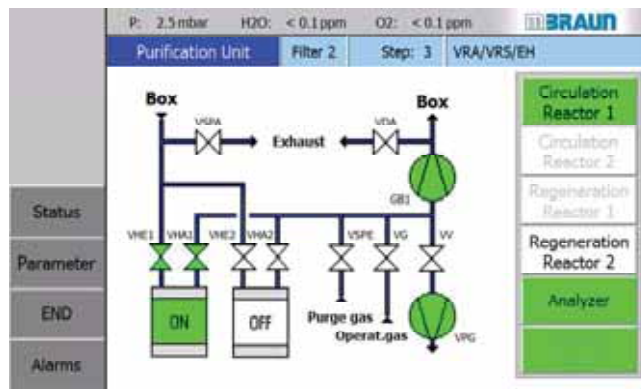

01321-1

Change to circulation operation 2-reactor system

2-reactor system after the regeneration

- Reactor 1 is in circulation operation:
- Reactor 2 is regenerated and is available for change to circulation operation.

Functions 1 screen

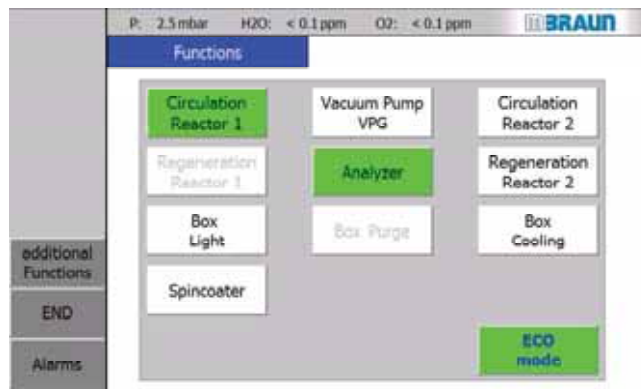

01160-2

- ▶ *On the Start screen:* call up Functions 1 screen

here: Functions 1 with 2-reactor system

Status after regeneration:

- Reactor 2: Circulation function is ready

Touch button [Circulation Reactor 2](#)

- circulation via reactor 1 is stopped and
- circulation via reactor 2 is started

- Reactor 1 is ready for the "Regeneration" function
- 2-REACTOR system – change to circulation operation

see 7.3.5.1

Gas purifier (O₂ and H₂O)

7.3.2.7 Contemporary regeneration of RKM + LMF (optional)

With additional vacuum pump LMF (VPGL)

A simultaneous regeneration is possible if the LMF is equipped with its own vacuum pump (VPGL).

With common vacuum pump (RKM + LMF):

The regeneration of RKM and LMF take place one immediately after the other:

- The regeneration started first has priority and runs automatically
- The regeneration started last persists after confirmation of the regeneration gas test in a maintenance step (step 2 of the regeneration programme).
- That is, only with a delay of 10 hours (MB20/200) is there switching to the next step.

7.3.2.8 After regeneration: empty condensate water container (optional)



After each regeneration:

Empty the condensate water container

- ▶ Hold empty vessel under the condensate water container
- ▶ Open screw below the condensate water container
- ▶ Drain the condensate water
- ▶ Seal screw again.

7.4 Gas Purifier Solvents (LMF)

Optional equipment internal or standing next to the gas purifier.

7.4.1 Technical Data

Manually-operated LMF - technical data:

Filling:	5 kg active carbon (MBRAUN item no. 2182000)
Suitability:	for aromatic and aliphatic as well as halogenated organic solvents; gasoline, kerosene, butyric acid, acid; in other cases the suitability must be checked.
Absorption capability:	approx. 100 g solvent per kg active carbon. The precise quantity depends on the solvent type and the environmental conditions – especially the ambient temperature.

Regenerative LMF - technical data:

Filling:	8 kg Mol sieve (MBRAUN item no. 3240262)
Suitability:	for aromatic and aliphatic as well as halogenated organic solvents; gasoline, kerosene, butyric acid, acid; in other cases the suitability must be checked.
Absorption capability:	approx. 100 g solvent per kg mol sieve. The precise quantity depends on the solvent type and the ambient conditions -- especially on the ambient temperature.

! **MBRAUN** offers sensors that measure the content of the solvent in the gas after it exits the filter. This way, saturation of the solvent filter can be detected early on. Ask **MBRAUN** Service.

7.4.2 Safety

The solvent filter (LMF) precedes the reactors for H₂O and O₂ (RKM). In case of incorrect operation, the following risk arises with a manually-operable solvent filter:



WARNING

With the enrichment of solvent vapours in the box atmosphere, reactors and solvent filters, there is a risk of ignition!

If the reactors and the solvent filters are not switched into circulation operation simultaneously, the solvent filter has no effect and there is an enrichment of solvent vapours in the box atmosphere!

With penetration of oxygen into the working area of the system, there is a risk of ignition!

- ▶ Always make sure that both solvent filters and the gas purifier are working in parallel in circulation operation.

Gas Purifier Solvents (LMF)

7.4.3 Manual valve controlled solvent filter LMF

Circulation operation

If a manually-operated solvent filter is assigned to a gas purifier ($H_2O + O_2$ reactor RKM), it can work in parallel to the RKM reactor in circulation operation.

Bypass operation

In bypass operation, the manual valves are set so that the box atmosphere circulates exclusively via the RKM reactors. This operating mode can be selected if no solvents accumulate in the box or for the replacement of the active carbon (see Chapter 12 Inspection and maintenance).

Valve scheme

The following diagram shows the arrangement of the valves that are necessary for the operation of the solvent:

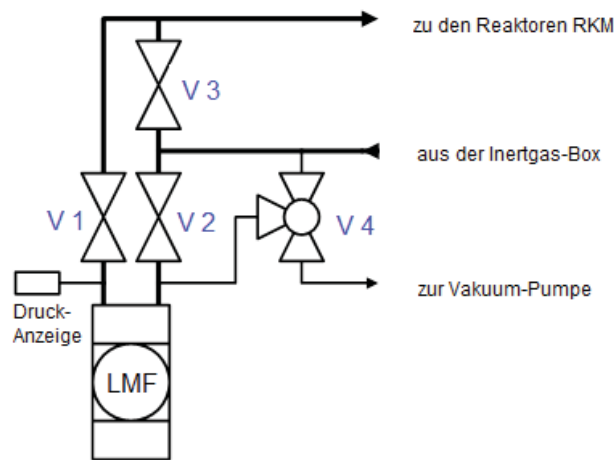

Circulation operation:	Bypass operation:
Operation: Gas purifier with solvent filter LMF	Operation: Gas purifier without solvent filter LMF
Valve 1 (V1) open Valve 2 (V2) open Valve 3 (V3) close	Valve 3 (V3) open Valve 1 (V1) close Valve 2 (V2) close
Valve 4 (V4) must be in the "closed" position.	Valve 4 (V4) must be in the "closed" position.

Maintenance mode for exchange of the active carbon

See valve scheme and description on the system and Chap. 12.5.9 Inspection and maintenance

7.4.4 PLC-controlled, regenerative solvent filter LMF

Analogous to the 1 and 2-reactor systems for H₂O and O₂ (RKM) there are 1 and 2-solvent filter systems (LMF). Solvent filter systems work in parallel to the RKM cleaning units and follow the same functional principle.

- ! The principle of circulation is the same for 1 and 2-filter systems. Systems with 2 solvent filters can be deployed more flexibly since one filter can be regenerated while the second filter remains active.

7.4.4.1 Overview LMF controller via touch panel

Start screen for system: 2 RKM and 2 LMFs

01102-2

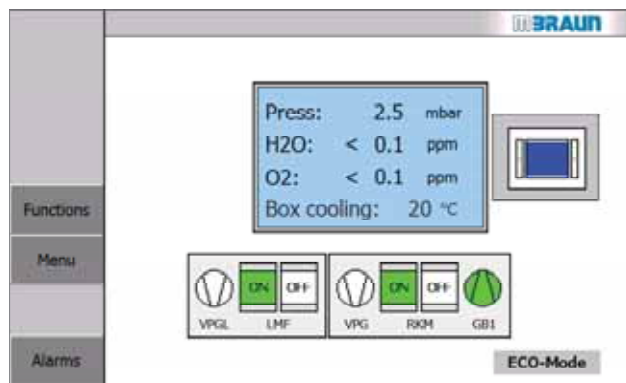

Navigate to the solvent filter screen

- ▶ Touch LMF symbol.

Display here: separate vacuum pump for LMF (optional)

Solvent Filter screen

01402-2

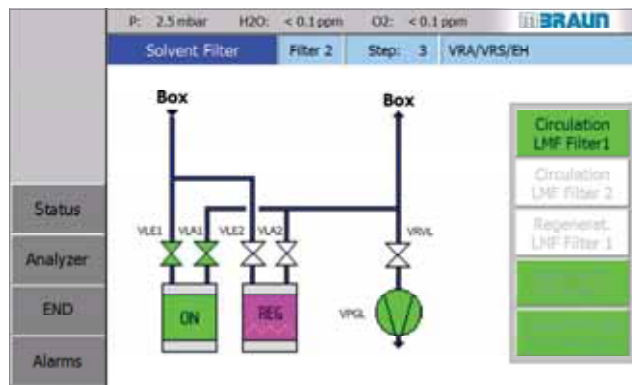

Solvent Filter screen :

Navigate to the Parameter or Status screen

- ▶ Touch navigation button Parameter + Status.

Display here: LMF 1 in circulation operation, LMF 2 in regeneration operation

Gas Purifier Solvents (LMF)

Solvent Filter Unit Status screen



Status	Filter 1	Filter 2
Remaining regeneration time [min]	0	0
Time since last regeneration [h]	9	0
Total time purifier [h]	94	24

01400-2

On the screen
"Solvent Filter Unit Status:"
*)

- Status indicator of the Solvent filter (LMF)

Example: 2-Filter-System

Solvent-Analyzer Parameter + Status screen

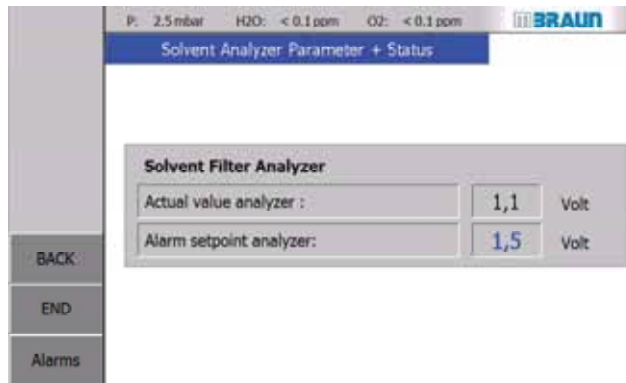

Actual value analyzer :	1,1	Volt
Alarm setpoint analyzer:	1,5	Volt

01400-3

Display on the screen "Solvent Analyzer Parameter and Status:" *)

- Solvent Filter Analyzer (optional): in Volt
- Parameter alarm setpoint analyzer

see also chapter

7.4.6 Solvent Analyzer

Note:

If no solvent analyzer is available:

- The navigation button „Analyzer“ in the screens „LMF-1-Filter“ / „LMF-2-Filter“ is shown
- On the screen Solvent Analyzer Parameter + Status a text field is shown:
“Option is not available”



Solvent Analyzer	
Actual value analyzer :	Option not available
Alarm setpoint analyzer:	Option not available

*) Note specifics of operation solvent analyzer without LMF, see 7.4.4.2

7.4.4.2 Activate or deactivate regenerable LMF (circulation operation)

Solvent Filter screen - 1-LMF system

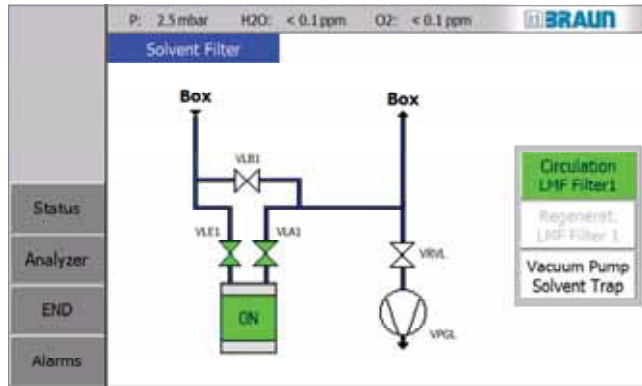

01401-2

Activating/deactivating the LMF (1-filter system):

Using the function keys:

- Circulation LMF Filter 1
- Regeneration LMF Filter 1
- Vacuum pump (VPGL) (optional for LMF)

Or: control via Functions 2 screen

Solvent Filter screen - 2-LMF system

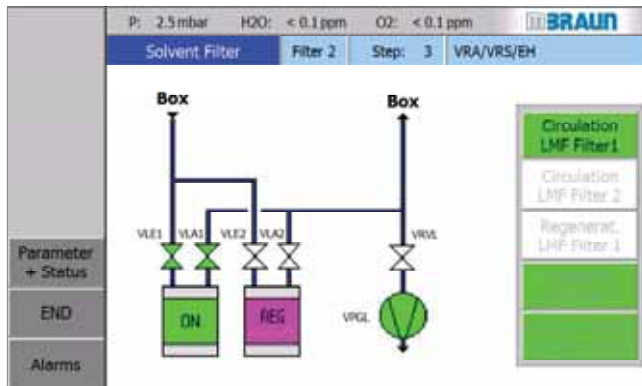

01402-2

Activating/deactivating the LMF (2-filter system):

Functions – alternatively Filter 1 or Filter 2:

- Circulation
- Regeneration
- Vacuum pump (VPGL) (optional for LMF)

Or: control via Functions 2 screen

Functions 2 screen

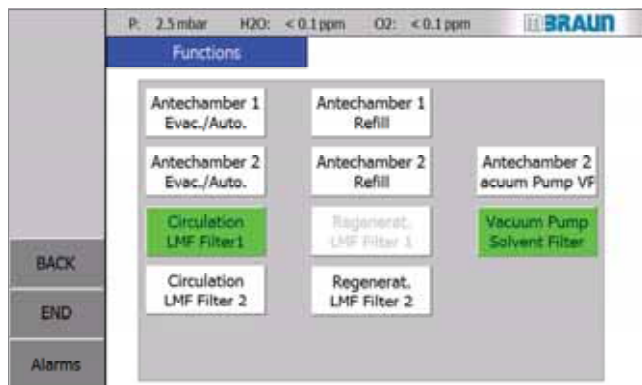

01161

Alternative:

Activating/deactivating operation of the solvent filter via Functions 2 screen

Call up screen with > Start screen > "Functions" navigation button > Functions 1 screen > Navigation button additional functions

Gas Purifier Solvents (LMF)

Touch button color changes from WHITE → to GREEN



Status LMF from OFF → to ON

Status vacuum pump VPGL for LMF:

The vacuum pump LMF automatically starts operation even if it was not previously activated (for 1 and 2-filter systems)

Touch button color changes from GREEN → to WHITE



Status LMF from ON → to OFF

Activating the circulation LMF:

- ▶ Touch button [Circulation LMF](#)
- the function "Regeneration" is blocked

Deactivating circulation LMF

- ▶ Touch button [Circulation](#)
- the "Regeneration" function of the LMF is ready

! System with two solvent filters (LMF):

If the system is equipped with a second solvent filter, the circulation operation can be switched to the second filter.

In parallel to this, the regeneration can be started for the second filter.

The functional principle is analogous to the O₂ / H₂O reactors (RKM) - see 7.3.2

7.4.4.3 Regenerate solvent filter

The regeneration of the solvent filter is done according to the same principle as the regeneration of the gas purifying system for O₂ and H₂O. (See Chap. 7.3.2.3)

Important: The regeneration of the solvent filter is done with pure inert gas (operating gas) - no inert gas/hydrogen mixture may be used! .

! Systems with 1 solvent filter are equipped with a bypass valve.

This way the solvent filter can be regenerated while the gas only circulates via the H₂O/ O₂ reactor.

7.4.4.4 Contemporary regeneration of RKM + LMF (optional)

With additional vacuum pump LMF (VPGL)

A simultaneous regeneration is possible if the LMF is equipped with its own vacuum pump (VPGL).

With common vacuum pump:

The regeneration of RKM and LMF take place one immediately after the other:

- The regeneration started first has priority and runs according to programme
- The last regeneration started persists after confirmation of the regeneration gas test in a maintenance step (step 2 of the regeneration programme). That is, that it is only switched with a delay of 10 hours (MB20/200) to the next step.

7.4.5 Solvent sensor (Option)

Using a solvent sensor (universal measurement gas sensor (UGP)), it is possible to measure the percentage of solvents in the box atmosphere (*Optional: see separate manual UGP*).

The measurement values distinguish themselves for the different solvents. Therefore, the value is displayed as a voltage between 0 V and 10 V. The displayed values behave proportionally to the concentration of the solution vapours that are measured after the escape from the solvent filter.

For detection of the capacity limit of a solvent filter (LMF), an additional analyzer can be integrated. This sensor measures the solvent concentration of the circulated gas and generates a warning, if the filter material is exhausted.

! With different solvents, the same alarm limit values can be triggered with different concentrations. Ask **MBRAUN** Service.

! The display can be adapted to a particular solvent (optional).
Ask **MBRAUN** Service.

Operation of solvent filters (LMF) with solvent Analyzer

Screen Solvent Filter - 2-LMF-System

01402-2

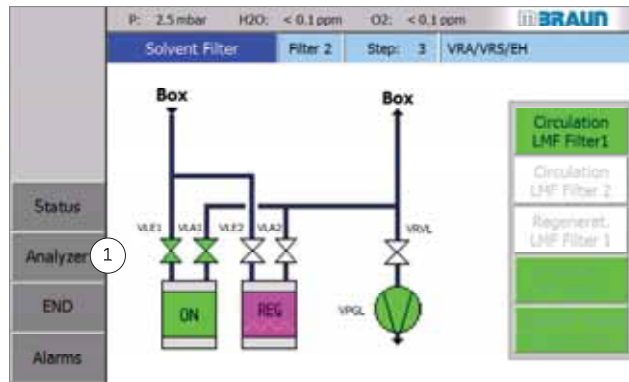

Analyzer

(5) Navigation button Analyzer

Navigation see 7.4.4.1

Field „Solvent Analyzer“

Screen Solvent Filter – Parameter and Status

01400-2

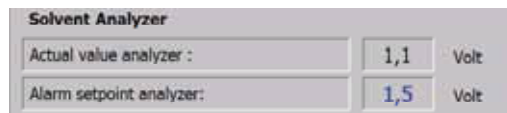

Display / Parameter Setting solvent analyzer:

Elektrische Spannung (Volt):

- Anzeige Istwert
- Parameter für Alarmschwelle

Gas Purifier Solvents (LMF)

Operation of Solvent Analyzer - without Solvent Filter (LMF)

Menu Screen Selection

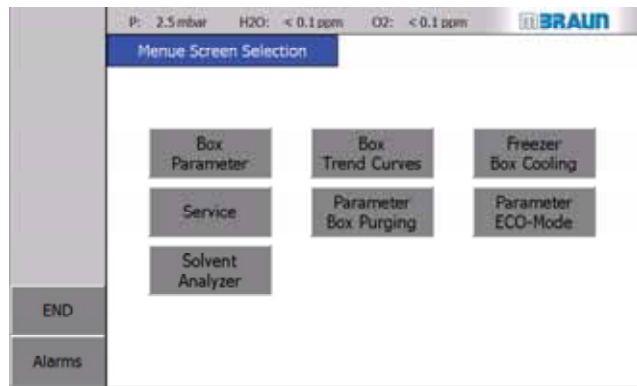

01120-1

On the screen
“Menu Screen Selection”:

If the system is not equipped
with an LMF, an additional
button **Solvent Analyzer** is
optionally available:

Call up the screen “Solvent
Filter Parameter and Status”:

- ▶ Touch the button
Solvent-Analyzer

8.1	Introduction	8-2
8.2	Safety	8-2
8.2.1	<i>In normal operation</i>	8-2
8.2.2	<i>In case of error / In case of improper operation.....</i>	8-3
8.3	Basic principles for safe work with the inert gas box	8-5
8.3.1	<i>Media connections</i>	8-5
8.3.2	<i>Heed openings of the box</i>	8-5
8.3.3	<i>Avoid material damage and leaks</i>	8-5
8.3.4	<i>Maintain inert gas atmosphere in the box.....</i>	8-8
8.3.5	<i>Working with the box's gloves</i>	8-9
8.3.6	<i>Making box ready for operation.....</i>	8-11
8.4	Basic principles of sensor monitoring of the inert gas atmosphere.....	8-13
8.4.1	<i>Display of the measurement values</i>	8-13
8.4.2	<i>PLC: activate/deactivate measurement devices.....</i>	8-15
8.5	Operation of the inert gas box	8-18
8.5.1	<i>Manual purging of the box.....</i>	8-18
8.5.2	<i>Controlling box pressure and atmosphere.....</i>	8-23
8.5.3	<i>Activate/deactivate box-related functions</i>	8-27
8.5.4	<i>Box during circulation operation</i>	8-28
8.5.5	<i>Box during regeneration operation</i>	8-31
8.5.6	<i>Box purge (optional).....</i>	8-32
8.6	Customer's applications in the p gas box	8-38
8.7	Additional functions and box equipment (optional)	8-39
8.7.1	<i>Additional box equipment (optional)</i>	8-39
8.7.2	<i>Box safety equipment (optional).....</i>	8-40

Introduction

8 Operation of the inert gas box

8.1 Introduction

The inert gas box allows the processing of materials that are sensitive to oxygen and moisture in the box. This function is secured by the set-up of the system and the controller. However, there are risks in case of error and due to incorrect operation if ambient air penetrates the box or inert box atmosphere penetrates outside and process materials come into contact with oxygen.

The quality of the box atmosphere in a closed system is ensured by adherence to the operational flows (*see also antechamber processes*).

The safety of the system depends entirely on the leak tightness of an undamaged box.

With this goal, safety instructions and basic rules for safe work with the inert gas box are provided here.

8.2 Safety

8.2.1 In normal operation

Pressure

Under normal operating conditions, a standard inert gas box is designed for a maximum interior pressure between -15 mbar and + 15 mbar (- 1500 Pa and + 1500 Pa).

Particular exceptional situations such as malfunctions of valves or components can cause extreme pressure situations in the inert gas box. At a pressure of approx. +/- 20 mbar (+/- 2000 Pa), the gloves separate from the feedthroughs.

In case of error, this type of pressure release for the box is only permissible if harmless gases and process materials are used.

Depending on the type of gases and process materials used, additional equipment may be necessary (*See below*).

Ambient air

At commissioning or after maintenance work, the box is filled with ambient air. Please note:

NOTICE

Circulation operation with ambient air in the box can damage the reactor medium and O₂ and H₂O sensors! Depending on the process materials, unknown risks may arise!

In case of an O₂ percentage in the box atmosphere of more than 100 ppm:

- Purge box with inert gas until there is an O₂ percentage in the box atmosphere less than 100 ppm

Follow the instructions "Manual purging of the box" in Chapter 8.5.1

8.2.2 In case of error / In case of improper operation

Risk of suffocation in case of error / in case of improper operation



DANGER

Risk of suffocation in case of improper operation!

Opening of an inert box and large leaks can create a risk of suffocation, especially if the on-site conditions are not fulfilled!

- Never stick your head into an inert antechamber/box!

- ▶ Always ensure good ventilation of the room!
- ▶ Make sure that flanges on the box are always sealed to the outside
- ▶ In case a glove tears, replace the glove immediately

Before opening the pane/box:

- ▶ Exchange the inert box atmosphere for ambient air!
- ▶ Open the box only after the oxygen content is > 19.5 %

Follow the instructions in Chapter 11, Troubleshooting and Chapter 12, Maintenance (glove replacement).

Risk of suffocation with permanently-active automatic box purging



DANGER

With permanently-active automatic box purging with inert gases: risk of suffocation

Risk of suffocation due to escaping inert gases in case of error (such as open flange, glove tear)! There can be a permanent gas escape into the ambient air and this can endanger life and health!

- ▶ Make sure that the parameter for the "Automatic switch-off" function is activated if there is no operator at the system
- ▶ Follow the description in this operating manual!

If the system is equipped with automatic box purging (optional) - see also Chap. 8.8

Basic principles for safe work with the inert gas box

Damage due to extreme pressure circumstances

Extreme pressure circumstances can arise due to malfunctions of valves or additional components. The degree of hazard depends

- on the gases and process materials used (see below Chap. 8.2.2.2).
- on the on-site conditions - in case they are not met!



DANGER

In case of error, extreme pressure circumstances can cause glove tears and risk of suffocation!

- ▶ Eliminate cause of the extreme under/over pressure
- ▶ Replace the gloves quickly -

While so doing never seal all gloveport feedthroughs with covers!

- ▶ Leave at least one gloveport feedthrough unsealed!
-

8.2.2.1 When using non-harmful gases/process materials

Under the assumption that only non-harmful gases and process materials are used, in case of error with extreme pressure circumstances (> 20 mbar) the gloves come off of the feedthrough. Therefore in the standard system there is a burst guard for the box.

NOTICE

In case of damage to the box/gloves of the box or in case of error (e.g. open flange): penetrating ambient air can damage sensitive process materials

- ▶ Eliminate the cause of the damage
 - ▶ Check process materials/products for damage
 - ▶ Before re-commissioning: purge the box atmosphere
-

(See also behaviour in case of over/under pressure of the box: Chap. 11, Troubleshooting).

8.2.2.2 Use of hazardous process materials

Standard systems (category 0) offer no personal protection! They are not properly designed for the use of health and environment-threatening process materials (category I-IV and EX).



DANGER

When using hazardous process materials

- ▶ Follow the instructions in the basic safety chapter for the classification and evaluation of substances (Chapter 3)
 - ▶ If necessary, ensure the application of the required additional equipment such as box pressure fuse, adherence to the O₂ values and exhaust disposal!
 - ▶ If necessary, please contact **MBRAUN** Service
-

8.3 Basic principles for safe work with the inert gas box

To maintain the inert gas atmosphere in the box and prevent the above-mentioned risks: at interfaces to the system, pay particular attention to:

8.3.1 Media connections

- Install properly
- Heed status of the valves
- Flange (optional)
- Always note that these e.g. after uncoupling of a media connection, must be sealed to the outside immediately

8.3.2 Heed openings of the box

Antechamber doors:

- Only open inner antechamber door if the antechamber atmosphere matches the box atmosphere and the outer antechamber door is closed

Quick-closures on box panes (optional):

- Only open for service purposes if the box is filled with ambient air and the oxygen content is > 19.5 %.

Gloveport feedthroughs

- (*see below*)

8.3.3 Avoid material damage and leaks

Material damage can be caused mechanically, chemically or by the influence of (UV/laser) radiation. Please heed the following notes:

Avoid extreme pressure increases/drops

Particular exceptional situations such as malfunctions of valves or components can cause extreme pressure situations in the inert gas box.

Prerequisite: no hazardous process materials/processes are used

At a pressure of approx. +/- 20 mbar (+/- 2000 Pa), the gloves separate from the feedthroughs. This causes pressure release in the box, thus preventing breakage of the box panes - however only if at least one gloveport feedthrough is not sealed with a cover.

Basic principles for safe work with the inert gas box**Manual valves in standard operation:**

- Heed valve position gas input/gas output:

Commissioning:	1. Open box output valve	2. Open box input valve
Decommissioning:	1. Close box input valve	2. Close box output valve

Particle filter of the box:

- Heed degree of saturation / differential pressure (see *Chap. 8.4.4*) and replace particle filter of the box in timely fashion.

Using additional equipment if necessary for pressure regulation:

- Over pressure securing of the box
- Automatic box purge function
- If necessary to secure pressure regulation if additional components that influence pressure are used in the box: (such as spin coater, particle absorber, feedthroughs for gas feed from external source directly into the box (etc.))
- Processes that generate high temperatures influence the box pressure; box cooling may be necessary.
- If safety equipment for pressure regulation and monitoring is installed: - never operate the system without safety equipment/alarm equipment - regularly check the functionality of the safety equipment (see *Chap. 8 A, 10 ...*)

Avoid mechanical effects from moving parts:

With the use of moving parts in the box (customer's equipment):

- Monitoring of the movement with light barriers, automatic stop,
- emergency off

If using pneumatic parts: risk of ejecting material

- Regular inspection and maintenance of pneumatic equipment

Chemical effects on materials

Make sure that the process materials used meet the specification of the material of the seals and gloves. Ask **MBRAUN** Service.

- If necessary, use a gripper tool
- Clean the sealing material/gloves carefully after contact with aggressive chemicals

Recommendation: with use of solvents in the box:

- Use of solvent removal filters and solvent sensors (see *Chap. 7.4 Gas purifier solvent filters*)

Minimise temperature effects (→ gloves)

Damage due to contact with hot surfaces:

With use of temperature-influencing additional equipment (freezer, heating plate, etc.), material ageing or damage to gloves and seals can arise:

- Wait before direct contact until the material has reached the ambient temperature
- If necessary, use a temperature-resistant gripper tool
- Follow the operating instructions for the special components

Influence of temperature on the pressure in the box (see above)

Protect material against effects of radiation

If using additional equipment/radiation-intensive processes:

UV light / laser

- Keep gloves out of the direct radiation area
- Check material of the gloves and seals regularly for damage

Reduce particle content in the box

In case of intensive particle formation in the box, **MBRAUN** recommends additional equipment:

- Differential pressure monitoring (optional)

In case of additional equipment/particle-intensive processes in the box:

- Heed degree of saturation of the particle filters of the box: saturated particle filters reduce the gas flow and increase the differential pressure of the blower

Basic principles for safe work with the inert gas box

8.3.4 Maintain inert gas atmosphere in the box

All (PLC-controlled) processes – such as circulation, antechamber processes - are aimed at maintaining a defined inert gas atmosphere in the box.

Prerequisite

- Purging of the box (see *Chap. 8.5.1 Manual purging of the box*)

For the measurement accuracy of the sensors, heed:

The controller works on the basis of the measurement values of the sensors (see also *Chap. 8.4*). Therefore always note:

- Switching of the sensors and switching on of the circulation only after reaching an O₂ concentration < 100ppm
- Adhere to cleaning and calibration cycles: H₂O sensors (MB-MO-SE1)
- Adhere to calibration cycles: O₂ sensors (MB-OX-SE1)

With use of additional sensors with own power supply (optional):

Please note:

- that the sensors are switched on
- that the valves are open and the measurement cells are in the gas stream

In case of interruption of the circulation, note:

In a box that is not in circulation operation, the O₂ and H₂O content constantly increase

- Keep box in circulation operation
- in case of longer interruption of the circulation: remove O₂ and H₂O-sensitive materials from the box or seal them safely in a container

8.3.5 Working with the box's gloves

The operator reaches into the box with the gloves in order to move materials in the box, execute process flows and operate the antechamber doors from inside.



Standard boxes are equipped with round gloveport feedthroughs and butyl gloves.

! Always wear cotton gloves in the gloves in the box.

NOTICE

Material damage and material ageing of the box's gloves due to particular materials and processes

- ▶ Check whether the gloves are suitable for the specification of your processes/process materials
- ▶ If necessary, use additional protection such as gripper tool, temperature guard
- ▶ Prevent damage to the gloves - due to sharp, pointy objects - due to rotating objects
- ▶ Avoid exposure to UV rays (laser) - extreme temperatures
- ▶ In case of damage to the gloves, ambient air penetrates the box, disturbs the inert gas atmosphere and can damage process materials and processes in the box.

A leak in the gloves is indicated, e.g. by a pressure drop and unstable O₂ and H₂O values in the box.

- ▶ Check the material of the gloves

If the system is equipped with an automatic function box purge, → an error message appears on the touch panel (See Chap. 11).

Basic principles for safe work with the inert gas box

- ! For the case that a glove change is required during ongoing operation:
- ▶ Practice behaviour in case of error and in case of glove replacement regularly (See *Chapter 11, Troubleshooting and your operation-specific standard operating manual as well as Chapter 12, Maintenance*)
 - ▶ Always keep appropriate spare gloves for the box at the ready (see *Chap. 13, Spare parts list*)
-

8.3.6 Making box ready for operation

Check at start of work/beginning of the week *)

		Power supply/switch on	Function on the panel	Valve check: open	Visual inspection of settings
ECO-Mode (optional)			x OFF		
Media supply					
Operating gas				X	Through-flow (pressure reducing valve)
Regeneration gas	Gas quantity			X	
Gas output to gas purifier				X	
Gas output to exhaust air					
Electrical system					
Gloves					Material
Seals					Material
Sensors (box + pipework)			x ON		
H2O			x ON		
O2			x ON		
UGP (optional)		X	x ON	X	
GSU (optional)		X	x ON	X	
H2 / other (optional)		X	x ON	X	X
Additional components in the box	Spincoater, particle absorber	Stand-alone: (x)	x ON	X	
Electrical system		X			
Cooling water				X	
Box warning equipment (optional)		X			
opto-acoustic		X			

Basic principles for safe work with the inert gas box

		Power supply/switch on	Function on the panel	Valve check: open	Visual inspection of settings
Safety equipment (optional)		X			
Light curtain		X			

Securing the system (nights, weekends)

In case of interruption of circulation operation:

- ▶ Remove sensitive materials from the box and secure
- ▶ Activate ECO-Mode (optional)

see Chap. 6 A.

8.4 Basic principles of sensor monitoring of the inert gas atmosphere

In standard systems, there is generally a measurement of the oxygen and moisture content of the box atmosphere (optional equipment).

- ! The sensors MB-OX-SE1 and MB-MO-SE1 are described in separate documentation.
 For special requirements, additional measurement sensors can be used (optional)
- e.g. a universal gas measurement probe (UGP) for the use of solvents
 - For the integration of measurement sensors into the PLC: additional display of the measurement value on the touch panel;
 - or special display on the separate combi monitor
- see additional chapter 10 A ff. and supplier documentation*

8.4.1 Display of the measurement values

Box pressure, H₂O and/or O₂ measurement values are displayed on the touch panel. If additional sensors are used (optional: solvents, helium, N₂, etc.) there is an additional display.

Measurement ranges (standard)

Oxygen sensor	MB-OX-SE-1	0.. 1000 ppm
Moisture sensor:	MB-MO-SE-1	0.. 500 ppm

Display of the measurement values

The measurement values are displayed on the permanent line and on the start screen:

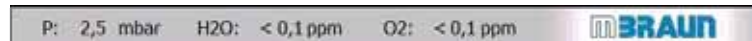

Display of the measurement values on the permanent line on each screen (*exception: start screen, see below*)

Basic principles of sensor monitoring of the inert gas atmosphere

Start screen

01103-1

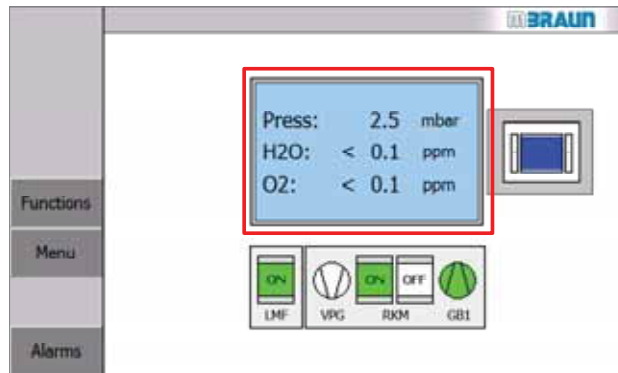

Display measurement values of the box atmosphere (pressure, H2O, O2 etc.)

(see Chap. 5)

Display constellations:

	No sensor configured
H2O: Switched off O2: Switched off	Sensor switched off
H2O: Sensor failure O2: Sensor failure	Sensor defective
H2O: < 0,1 ppm O2: < 0,1 ppm	Operating indicator

Dependencies H2O sensor – O2 sensor

The H2O sensor is only switched on → if the O2 concentration in the box is <999.9 ppm

(see also: Chap. 6, Operating modes, commissioning)

8.4.2 PLC: activate/deactivate measurement devices

Please note:
 If separate measurement devices with their own power supply are used:
 ► Switch device ON → only then can there be an activation via the PLC

Functions 1

01160-1

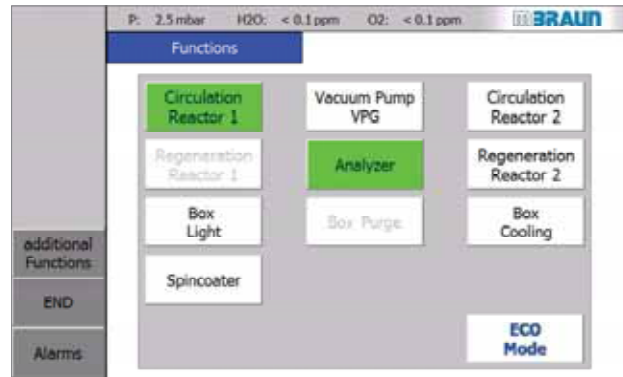

Variant 1:

Functions screen

Gas purifier

01310-2

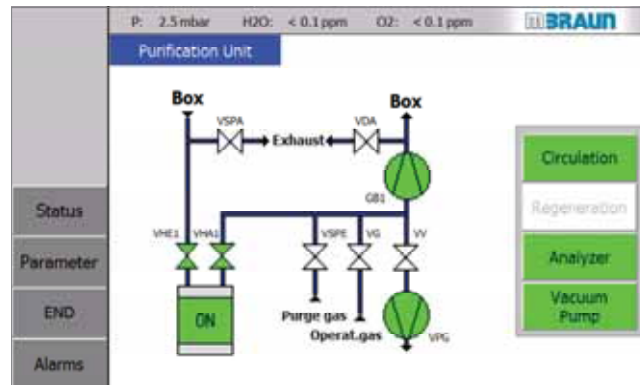

Variant 2:

Purification Unit screen

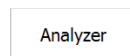

Switching on

► Touch button Analyzer

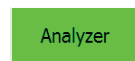

The colour of the function key changes from WHITE → to GREEN

Switching off

► Touch button Analyzer again

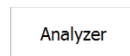

The colour of the function key changes from GREEN → to WHITE

Basic principles of sensor monitoring of the inert gas atmosphere

Please note:

The sensors are switched OFF automatically after 30 minutes if the box is not in operation -- that is, neither circulation nor box purging are active.

This serves to protect the measurement cells that should always be purged with box gas.

Securing measurement precision

- ! The operation of the sensors with an oxygen content greater than 1000 ppm (e.g. in air) must be avoided.

After an exposure to the ambient air, it can take several hours until the sensor provides accurate measurement values about inert gas conditions again.

Calibration of the measurement devices

MBRAUN measurement devices are calibrated at the factory before delivery.

The calibration cycles depend on the use of the measurement devices and the gases used (purity, trace gases, etc.).

- ! It is recommended that you have the measurement devices calibrated once a year by **MBRAUN** specialized personnel. Please use the included decontamination explanation in *Chap. 12*.

- ▶ For more information, please contact **MBRAUN** Service.

Moisture sensor MB-MO-SE1

- ! In order to achieve optimal measurement results, the sensor element MB MO-SE-1 should be cleaned routinely every three months or at the latest after 2000 hours of operation.

- ! Insufficient maintenance of the moisture sensor causes imprecise measurements and compromises the cleanliness of the box atmosphere, after 2000 hours of operation a cleaning of the sensor is necessary!

- ▶ Clean the moisture sensor at the latest when asked to do so by the warning message (96).

Clean moisture sensor, reset operating hours

Call the screen **Service H₂O-Sensor** from the **General Parameters** screen.

Service Moisture Analyzer

01705

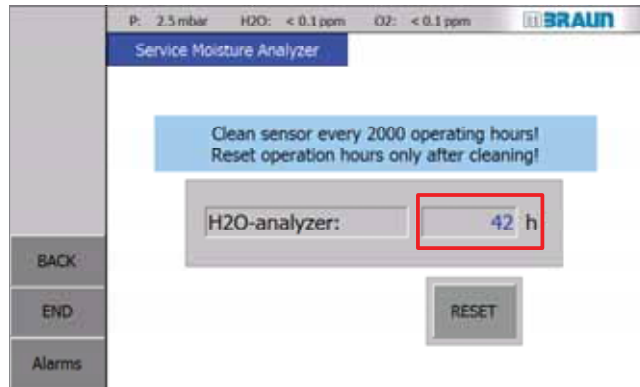

"Operating hours" field

Enter value "0" in the "Operating hours" field or:

▶ Touch button Reset

If more frequent maintenance should be conducted, the parameter "2000 Operating hours" can also be reduced.

 Operation of the inert gas box

8.5 Operation of the inert gas box

8.5.1 Manual purging of the box

Note: Analyzers will not read accurately during manual purging of the box. They will typically read a false low value

If the box contains ambient air – such as on commissioning, after service work or in case of disturbances (leaks, glove tear) – the box must be purged. Only if the remaining oxygen content has a value of less than approx. 100 ppm is the box prepared for the switching on of the sensors and for the change to circulation operation (see above, *sensor monitoring and Chap. 7.3.2*).

NOTICE

Damage to the sensors and the reactor medium due to O₂ and H₂O in the ambient air!

Circulation operation in ambient air can cause overheating of the reactor material and destruction of the valves and damage to the O₂ and H₂O sensors.

If ambient air gets into the box:

- Purge box with inert gas from external source until there is an O₂ percentage in the box atmosphere of less than 100 ppm

Note: Manual purging is not a standard feature on Labmaster and MB20/MB200 systems. See section 8.5.6 for directions on using the automatic box purge feature

The external purging can take place in two ways:

- Manual purging. In standard operation the purging of the box with operating gas of medium purity from external source (e.g. bottle supply). This procedure is described below.
- PLC-controlled purging via the manual or automatic box purge function (Optional: see *Chap. 8.5.6 Purging the box*)

Prerequisites for the manual purging of the box:



WARNING

Risk of suffocation if the on-site conditions were not adhered to!

If the on-site conditions cannot be adhered to:

- ▶ Divert used purging gas via an in-house exhaust air system!
 - the installation is complete (see Chap. 4)
 - All antechamber doors are closed
 - Equipment components in the box are switched off
 - Controller - touch panel: the system functions "regeneration" and "circulation" are switched off
 - Manual LMF in Bypass mode when applicable.

Pay special attention to all areas of the box in which there are not many gas movements (corners and areas surrounding installed equipment), especially open sealed room areas and purge them (e.g. storage containers, equipment such as freezer,

spincoater, etc.).

Action sequence manual purging of the box with a Manual Purge Valve

Step	▶ Action at gas source	▶ Box Operation
1		Set upper working pressure to 14 mBar Ser lower working pressure to 10 mBar Return to home screen
2	Check purge gas quantity: approx. 10 - 12 m ³ per 1 m ³ box volume (3-4 cylinders per 1 m ³ box volume) A standard two glove Unilab is approximately 0.8 m ³	
3		Switch installed components (refrigerator, drying oven, etc.) in the box OFF;
4	Ensure pressure increases to 10-14mbar	Ensure pressure increases to 10-14mbar
5		Open Valve on top of box (valve shown in closed position)
6	Allow ~3 tanks to purge for a two glove Unilab box. Turbulating the atmosphere with a fan or by waving the gloves will reduce the amount of gas need.	
7		Close Valve on top of box
8		Set pressure back to normal working setpoints Typical: Upper working limit 5 mBar Lower working limit 0.5 mBar
9		If system is equipped with analyzers turn analyzers on and allow reading to stabilize
10		Turn Circulation on. If level spikes above 100PPM stop circulation and resume purging

Operation of the inert gas box

Action sequence manual purging of the box with a hose

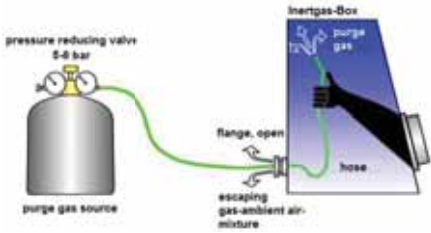
Step	▶ Action at gas source	▶ Handling in the box (with fixtures)
1	Provide purge as supply equipment (e.g. bottle) with pressure reducing valve.	
2	Check purge gas quantity: approx. 10 - 12 m ³ per 1 m ³ box volume	
3		Switch installed components (refrigerator, drying oven, etc.) in the box OFF;
4	Connect gas hose to purge gas supply.	
5	Set pressure reducing valve to 3-5 bar and open.	
6		Remove blind flange on the rear side of the box.
7		Insert gas hose into the box through the open flange.
8		Use gloves to reach gas hose into the box and purge the inside of the box from top to bottom with circular motions. Purge intermediate areas, corners, edges carefully.
9		<p>Installed equipment with closed areas (refrigerators, drying ovens) etc.)</p> <p>Open interior space:- match temperature to room temperature (e.g. in case of ovens, refrigerator)</p> <p>- Purge interior space carefully</p>
10	After through-flow of the calculated gas quantity: Close gas source	
11		Remove gas hose from the box – and while so doing, cover the flange opening with a flat hand
12		Close opening immediately with blank cap on the rear side of the box
13		If system is equipped with analyzers turn analyzers on and allow reading to stabilize

Step	▶ Action at gas source	▶ Handling in the box (with fixtures)
14		Turn Circulation on. If level spikes above 100PPM stop circulation and resume purging

 Operation of the inert gas box

Systems with measurement devices: checking the oxygen content in the box

 For systems equipped with the oxygen measuring device MB-OX-SE1 (O₂ sensor) :

After the purging: Determine O₂ value:

Step	Prerequisite	Action: touch panel:	Action: Box
>	The action sequence "manual purging" is carried out		
1	Through-flow of approx. 5 m ³ purging gas per 1 m ³ box volume	<i>[Multi-box system: switch box on]</i> Switch circulation ON: establish slight over pressure	
2		<i>Switching measurement devices on (Functions screen)</i>	
3		Observe display of O ₂ value.	
4	Display O ₂ value: - within approx. 10 sec. a declining tendency and - O ₂ < 100 ppm	<i>Prerequisite is not fulfilled:</i> Switch circulation OFF	
5			Repeat: sequence manual purge for approx. 2 minutes (see above steps 4 to 12)
6	Display O ₂ value: - within approx. 10 sec. a declining tendency and - O ₂ < 100 ppm	<i>Prerequisite is fulfilled:</i> The normal operating state is reached – continue the "Circulation" function	

Systems with 2 measurement devices: oxygen sensor MB-OX-SE1 and moisture sensor MB MO-SE-1

The switching on of the moisture sensor is done depending on the oxygen sensor:

Step	Prerequisite	Controller
1	Oxygen sensor: O2 concentration in the box is < 999.9 ppm	The moisture sensor MB-MO-SE1 is switched on

8.5.2 Controlling box pressure and atmosphere

8.5.2.1 Overview of parameters

The table in *Chapter 5.6 Pre-set parameters* provides an overview of the pre-set parameters for a standard system.

8.5.2.2 Parameters for the box

Navigating with the Menu Screen Selection

Menu Screen Selection

01120-1

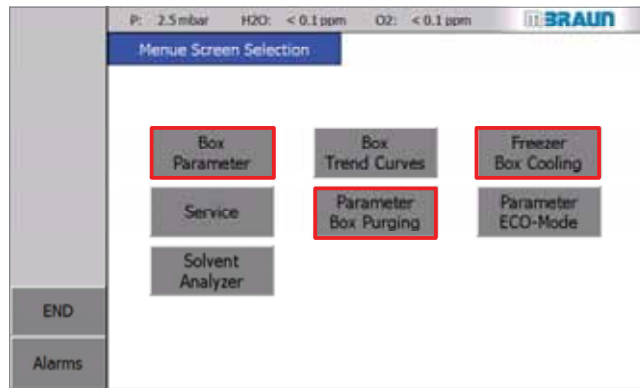

Selection of box-related parameters:

- Box pressure → Box atmosphere
- Temperature (box cooling, freezer – optional)
- Box purge (optional)
- *Solvent Analyzer (optional, if no solvent filter is integrated to the PLC – s. chapt. 7.4.4.2)*

Operation of the inert gas box

Box pressure parameters

01500-2

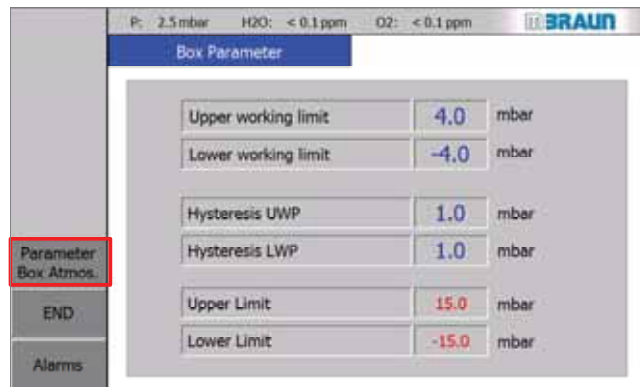

The screenshot shows the 'Box Parameter' menu with the following settings:

Parameter	Value	Unit
Upper working limit	4.0	mbar
Lower working limit	-4.0	mbar
Hysteresis UWP	1.0	mbar
Hysteresis LWP	1.0	mbar
Upper Limit	15.0	mbar
Lower Limit	-15.0	mbar

Navigation buttons on the left: Parameter, Box Atmos., END, Alarms.

Input of parameters:

- ▶ Touch numeric field:
- ▶ Input is done using the alphanumeric field

The basic principles for the function of pressure regulation are described in Chap. 2.3.3.

Operational limits – setting alarm limits:

- > The value of the upper operational limit must be less than the value of the upper alarm limit,
- > The value of the lower operational limit must be greater than the value of the upper alarm limit.

Upper and lower alarm limit

- > Setting only by **MBRAUN** Service

Parameters for box atmosphere (O2 and H2O)

Parameters for box atmosphere (O2 and H2O)

01500-1

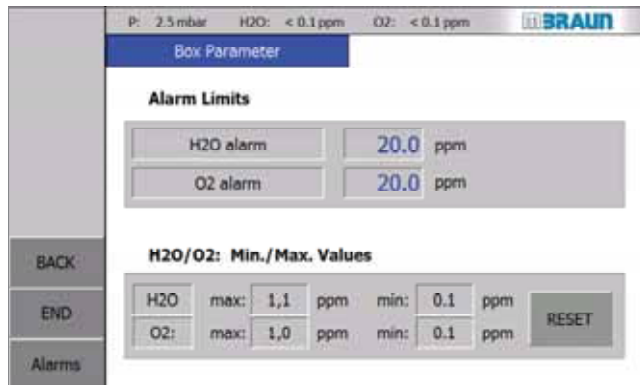

The screenshot shows the 'Alarm Limits' menu with the following settings:

Parameter	Value	Unit
H2O alarm	20.0	ppm
O2 alarm	20.0	ppm

H2O/O2: Min./Max. Values

Gas	max:	min:	Unit
H2O	1,1	0.1	ppm
O2:	1,0	0.1	ppm

Navigation buttons on the left: BACK, END, Alarms. A RESET button is also present.

Temperature parameter

Temperature parameter (freezer / box cooling)

01590-1

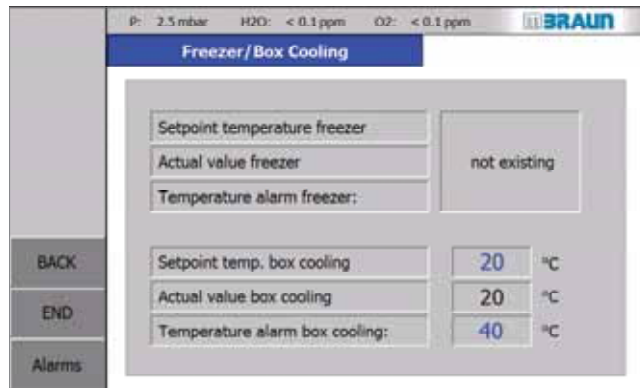

! The input fields are only active if the system is equipped with the appropriate components. If not, then "not present" is indicated in the input field.

! Settings and functions of freezer and box cooling:
see separate Chapter / Documentation 10 A. ff and Chap. 15 Supplier documentation.

Temperature	Target value	Actual value
Box cooling	10°C to 40°C	see display
Freezer	-35°C to 10°C	see display

Purge box parameters (optional)

See below, Chap. 8.8 Box purging, PLC-controlled

Operation of the inert gas box

8.5.2.3 Inert gas atmosphere trends

The course of the oxygen and moisture content and of the box pressure is displayed on the following screen:

Box Trend Curves



01502

Navigation: Menu Screen Selection > Box Trend Curves

→ Display of the current course of H₂O, O₂ and box pressure:

Display of course over 24 hours:

▶ Touch button 24h

Shift time axes: see Chap. 5.3.6

8.5.3 Activate/deactivate box-related functions

Functions 1 screen

01160-1

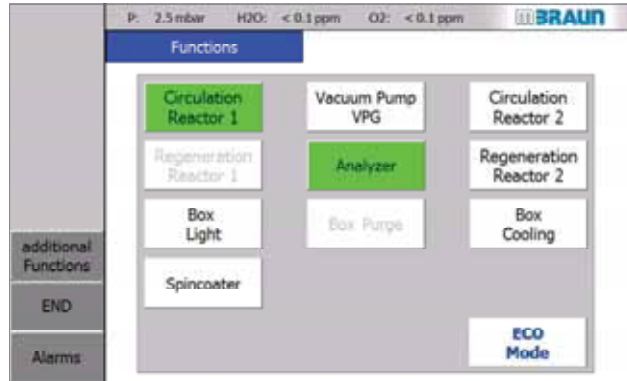

The box-related functions are switched ON and OFF using the "Functions 1" screen:

► Touch the button in question:

Box Light	Switch the box light on/off
Analyzer	Switch measurement devices (O2 and H2O) on and off
Circulation Reactor 1	Switch circulation function on/off <i>See also Chap. 8.5.6 Purging the box</i> <i>Box is in operation: circulation here via reactor 1 see also Chap. 7 Gas purifier</i>
Box Purge	<i>Alternatively: Automatic "Box Purge" or Manual Purge – see 8.5.6</i> Switch the "Automatic box purge" function on and off <i>Example above: the function is blocked since the circulation function is active</i>
Manual Purge	<i>Alternatively: Box Purge or Manual Purge – see 8.5.6</i> Switch "Manual box purge" function on and off
Box Cooling	Switch "Box cooling" function on/off
Spincoater	Integrated additional components (optional) – function as autonomous units, are activated/deactivated via the touch panel: <i>here: Spincoater</i> Switch on the off the additional components that are used in the box

Operation of the inert gas box

8.5.4 Box during circulation operation

The basic principles of circulation operation are described in Chapter 7 Gas purifier.

For the operation of the box, please heed the following peculiarities with respect to the management of the box atmosphere

8.5.4.1 Distinctions 1- and 2-reactor systems

1-RKM system

In circulation operation, the box atmosphere circulates between the box and gas purifier. The O₂ and H₂O content of the box atmosphere is monitored by sensors (optional) and a stable box atmosphere is maintained according to the parameters set.

The circulation is switched off during the course of the regeneration programme and the function blocked. It can only be activated again after completion of the regeneration programme.

1-RKM with automatic circulation

If the automatic circulation is switched on, the circulation starts automatically after completion of the regeneration programme (see Chap. 7.3.1.2).

2-RKM system

A 2-RKM system allows continuous processes in the box since one purifier unit apiece is in circulation operation, while the other is being regenerated or is in stand-by mode. A stable box atmosphere is thus guaranteed without interruption.

Blocked functions

During circulation operation of a purifier unit, the following functions are blocked:

- "Regeneration" function
- "Purge box" function

See Chap. 7.3.2

NOTICE

Process materials can be compromised if the circulation is switched off since the degree of purity of the box atmosphere declines proportionately over time.

Process materials that require great purity of the box atmosphere

- ▶ secure in a container that can be sealed
 - ▶ remove from the box
-

8.5.4.2 Pressure regulation and monitoring

For normal operation, the box pressure is PLC-regulated in a defined range.

Status box pressure – Status gloves

The status of the box pressure can be determined from the status of the gloves:

Over pressure: gloves directed to the outside

Under pressure: gloves directed to the inside

Display on the touch panel

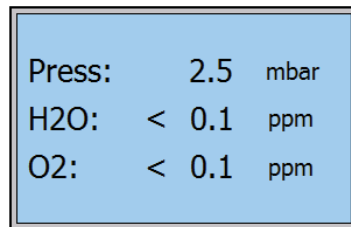

Display of measurement values

on the Start screen

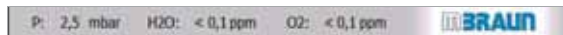

on the permanent line

PLC-regulated pressure monitoring

With the defined parameters, the pressure regulation is set within the operating limits and the gas feed/gas removal is regulated.

For functioning of the pressure regulation: see Chapter 2.3.3 Setting the parameters for the operating limits, hysteresis and alarm limits: see 8.6.2

Detection of open pane or glove tear.

If on activation of one of the two valves VG/VV after a delay time a defined pressure increase or pressure drop ramp is not achieved, then an error message "Box open or glove tear" is displayed on the panel.

This monitoring is only active in the pressure range $\geq + 2\text{mbar}$ and $\leq - 2\text{mbar}$ ($- 2\text{mbar} \geq P \geq + 2\text{mbar}$).

Settings on the panel may only be made by **MBRAUN** Service.

Operation of the inert gas box

Setting pressure with the foot switch

By pressing the foot switch, it is possible to adapt the pressure in the inert gas box within the defined operating range as needed (see 2.3.3.3).



Reduce pressure: ↓

- ▶ Press left foot pedal.

Increase pressure: ↑

- ▶ Press right foot pedal.

- ! The activation time of the foot switch is limited to 7,5 sec, due to safety aspects. Afterwards, actuate the foot switch again.

Keep pressure constant in case of reaching into the gloves of the box:

If you want to reach into the gloves in a box with positive box pressure:

- ▶ first reduce pressure slightly.

If you remove your hands from the gloves:

- ▶ increase pressure slightly

Mechanical securing box over pressure

Replacing the gloves



WARNING Only permitted with use of non-harmful process materials/process gases

In case of error (e.g. defective valve) and increase of box pressure to $> 20\text{mbar}$:

- The gloves separate from the gloveport feedthrough.
- Thus the box/box pane are protected against rupture (see also Chap. 11 - Behaviour in case of error)

Securing of box over pressure via pressure control valve (optional)



WARNING With use of sensitive process materials (product protection) or process materials/process gases that could harm health or the environment (personal protection), additional safety equipment such as the following is necessary

- Box pressure control valve (optional)
- and connection to an in-house exhaust system (optional)

See also optional additional chapter 8 A.

8.5.5 Box during regeneration operation

The basic principles of regeneration operation are described in Chapter 7 Gas purifier. For the operation of the box, please note the following peculiarities:

1-reactor system (RKM)

For systems with one reactor, there is no gas purification process during regeneration and the quality of the box atmosphere declines proportionately with time.

Recommendation

During regeneration, processes in the box should only be continued if non-sensitive materials are used.

Otherwise regeneration should, if possible, be done after the end of a work day overnight so that on the next day the required quality of the box atmosphere in circulation operation is available.

2-reactor system (RKM)

In the 2-reactor system, 1 reactor apiece is in circulation and 1 reactor is in regeneration operation. This guarantees a stable box atmosphere. Processes in the box can be carried out without interruption.

1- or 2-reactor system (RKM) and solvent removal filter (LMF)

NOTICE

Solvent vapours attack the sealing material of the box panes and antechambers and damage the reactor medium of the H₂O and O₂ reactors.

Manual LMF:

With use of solvents in the box, it must be heeded that the solvent filter is always switched on (required for manual LMF) - (see *Chap. 7.4*).

Automatic LMF

An automatic LMF is switched on PLC-controlled.

Recommendation

If there is a high concentration of solvent vapours due to processes in the box and/or continuous processes in the box are necessary:

- ▶ Work with a 2-filter LMF system where 1 reactor can work in circulation and 1 in regeneration operation
- ▶ If necessary use a solvent sensor (UGP)

Please contact **MBRAUN** Service.

Operation of the inert gas box

8.5.6 Box purge (optional)

For the purging of the box with direct feed of inert gases, there are optionally 3 different functions available that are controlled via the touch panel:

Function	Description	Valves	Chapter
Manual purge	<ul style="list-style-type: none"> Function is included by default with equipment with ECO-Mode Systems without ECO-Mode: optional 	VG + VDA	8.5.6.1
Purge box MB-BS-200-PLC	<ul style="list-style-type: none"> Optional function 	VSE + VSA	8.5.6.2
Automatic box purge	Prerequisite: equipment of the system with MB-BS-200-PLC; <ul style="list-style-type: none"> Automatic is set and activated/deactivated using parameters 		8.5.6.3

Purging the box:

Typically the Labmaster or MB20/MB200 will include an automatic purging feature. And manual purging is not required.

- Purging via touch panel:
 - Manual activation of the function "Manual box purge" (optional) button [Manual purge](#)
 - Manual activation of the function "Automatic box purge" (optional with equipment with MB-BS-200-PLC) via button [Purge box](#)

Both functions are only available with circulation operation switched OFF.

In operation for balancing out / maintaining the inert box atmosphere

- Manual purge of the box via touch panel (optional) [Manual purge](#) (with circulation operation switched OFF and low gas flow)
- Box purge via touch panel (optional) [Purge box](#) (MB-BS-200-PLC) (with circulation operation switched OFF and higher gas flow)
- Box purge automatic – (optional): Here the circulation operation is only interrupted during the purging initiated automatically.

! Display of measurement values during manual box purge:

Primarily the oxygen and H₂O values of the purge gas are measured - and not the values of the box atmosphere!

- ▶ The display of the moisture and oxygen sensors must be ignored

After the manual box purge and after switching on the circulation:

The sensors only display the actual box values after a few seconds

8.5.6.1 Manual start function "Manual purge" (optional)

The "Manual purge" function should be used primarily to balance out larger temporary contaminations of the box atmosphere. It can also be used for (re)commissioning.

Prerequisites:

- > All connections (external operating gas supply, connection to in-house exhaust system) are made properly
- > There is sufficient purging gas (=operating gas from external source)
- > The system is switched on
- > The box to be purged is switched on (optional for multi-box operation)
- > The "Circulation" system function is switched OFF
- > The function key is released

Operation:

Functions 1 screen

01160-5

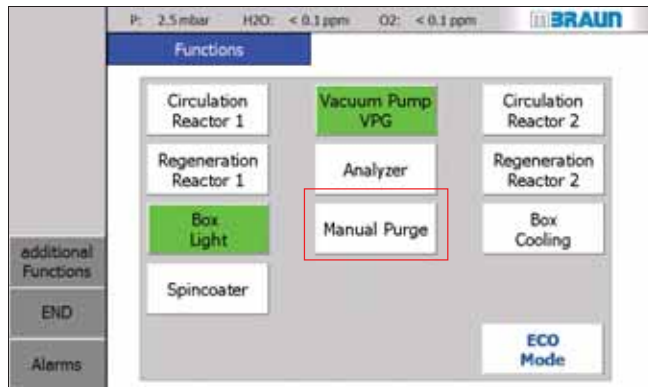

Activating/deactivating the function:

- ▶ Touch button **Manual purge**
- Deactivate:
 - ▶ Touch button **Manual purge** again

Safety switch-off of the "Manual purge" function

The duration of the purging is limited: it is deactivated automatically after 2 hours.

Functions 1 screen

01160-5

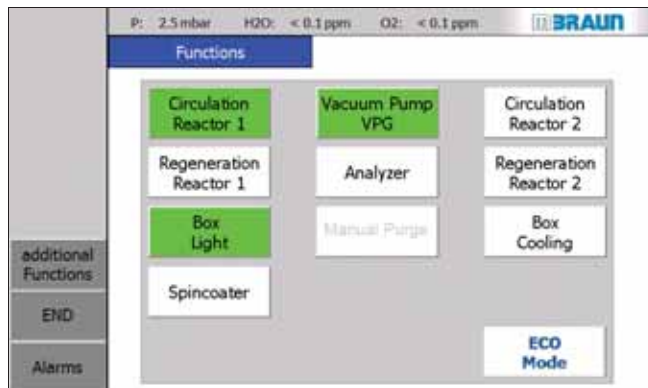

After ending: switch circulation ON:

- ▶ Touch button **Circulation reactor 1**
- the circulation starts
- the **Manual purge** function key is blocked

Operation of the inert gas box

8.5.6.2 Manual start function "Box purge" (optional)

The "Purge box" function is only available if the system is equipped with the function MB-BS-200-PLC, which allows a quick purging of the box.

Purging of the box is activated manually via the "Purge box" function on the touch panel:

Manual activation / deactivation

Prerequisites:

As above (8.5.6.1)

Operation:

Functions 1

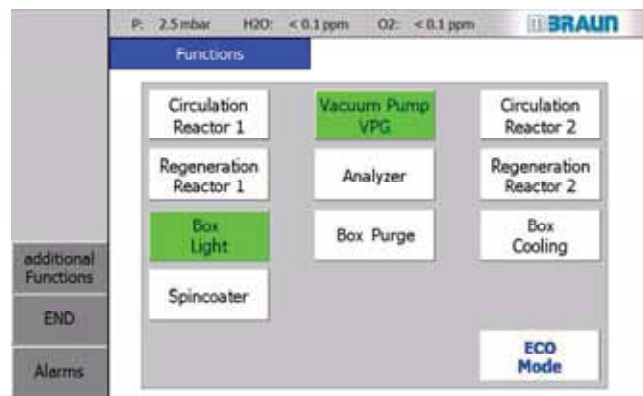

01160-4

Prerequisite

- > Circulation reactor (1 + 2) switched off
- > button **Box Purge** is released

Activate the function:

- ▶ Touch button **Box Purge**

Deactivate:

- ▶ Touch button **Box Purge** again

Safety switch-off of the "Purge box" function

The duration of the purging is pre-set to 60 min. and can be set on the "Purge box parameters" screen. See the following section – Automatic box purge.

Functions 1

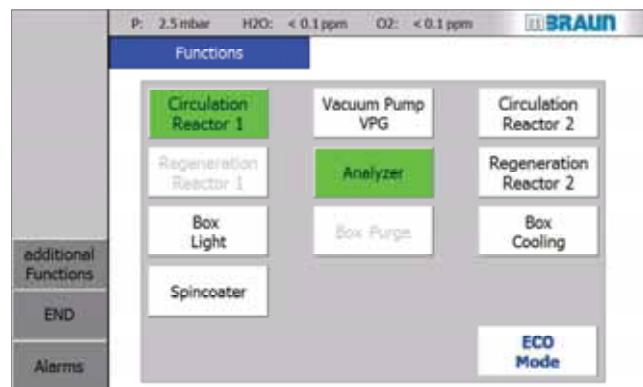

01160-1

After ending: activate circulation

- ▶ Switch Purge box OFF
- ▶ activate button **Reactor circulation**
- the circulation starts
- the **Box Purge** function is blocked

8.5.6.3 Automatic box purge - (optional)

With the automatic box purge, there is a PLC-controlled purging of the box from an external gas source. The purging of the box is activated at a defined limit value.

As reference values, measurement values for different materials can be parametrised in the PLC - generally the oxygen content is the reference value, other measurement values such as He, N₂, H₂ or solvents can be set up optionally (*see also Chap. 8.4*).

This provides a constant quality of the box atmosphere. For example, in case of error during circulation operation, an increase of the O₂ concentration in the box is prevented.

Safety



DANGER

Risk of suffocation due to escaping inert gases in case of error (such as open flange, glove tear) if the automatic box purging is permanently activated!

If the operator is away from the system (break times, overnight, weekend):

- ▶ Make sure that the parameter for the "Automatic switch-off" function is activated (*see automatic box purge parameters, next page*)
- ▶ If the automatic switch-off is deactivated: ensure a securing of the ambient air in the work room (ensure sufficient ventilation, connected Purge box output to an in-house exhaust air system).

Safety switch-off:

In case of error – such as glove tear, open flange or open pane – there is an O₂ increase in the box and with permanently-activated box purging, unlimited operating gas is fed in, which gets into the ambient air.

In order to limit this potential risk of a permanent feed of operating gas into the ambient air, the duration of the automatic box purging can be limited via parameter setting. It is pre-set by MBRAUN to 60 min.

Exception – responsibility of the operator:

Depending on the room size, ventilation or connection of the box purge output to an in-house exhaust air system, the automatic deactivation can be switched off (*see below, Parameters section*). The operator must ensure that there are no risks to people in the room.

Please heed the safety instruction above and follow the description in *Chap. 8.8.1*:

Operation of the inert gas box

Automatic box purge parameters

! Heed the information above and the safety instructions.

Box purge parameters

01500-4

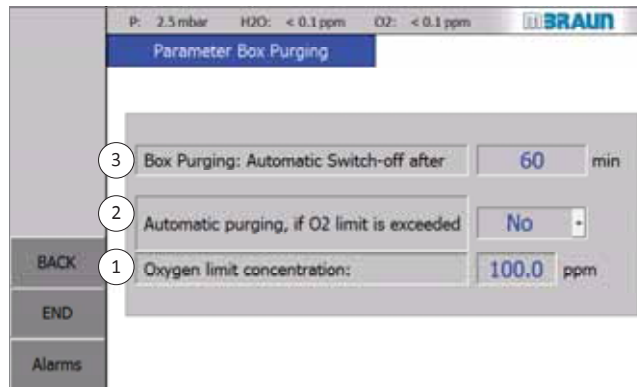

On the "Parameter Box Purging" screen, the following can be set:

Oxygen limit concentration: 100.0 ppm

Limit value

→ adjustable value

for the switching on of the automatic box purging function (*here: O2*)

Automatic purging, if O2 limit is exceeded: Yes

Activation / deactivation

The automatic "Purge box" function can be switched optionally ON or OFF.

Box Purging: Automatic Switch-off after: 60 min

Automatic switch-off

Risk of suffocation!

If the function is deactivated, the error case is no longer secured!

In case of gross leaks in the box, there can be an unintentional gas feed into the room!

- ▶ Heed safety instructions!
- ▶ Secure ambient air (ventilation / connection to exhaust air system)!

Switching on again

The purging function can be started again manually right away.

Adjustment range: 1..999 min ; Default: 60 min
value 0 min = function deactivated

How the PLC-controlled automatic box purge works

On the Purge box parameters screen:

- Automatic purge on exceeding of the oxygen concentration is selected with "Yes":
 - The inert gas box is purged immediately automatically with exceeding of the set O₂ alarm threshold.

The hysteresis for the deactivation of the automatic box purging is 10% of the specified limit value.

Example:

Limit value	= 100 ppm
automatic purging ON at O ₂	≥ 100 ppm
automatic purging OFF at O ₂	≤ 90 ppm

Activation of the automatic processes

Prerequisite

- > Parameter O₂ limit value is defined
- > Automatic purge on exceeding of the O₂ concentration is selected with "Yes"
- > Circulation is switched ON
- > Measurement devices are switched ON and work perfectly

(see parameter box 8.8.2)

Automatic initiation of the box purging

Status	Initiated process of the automatic box purge
Limit value is exceeded	→ Circulation operation is interrupted → Gas is fed into the box → Monitoring of the box values

Automatic end box purge:

Status	Initiated process of the automatic box purge
Limit value is under-run again:	→ Gas input and output valves are closed → Circulation operation starts automatically

Customer's applications in the inert gas box

8.6 Customer's applications in the inert gas box

Additional customer equipment, process materials and processes are only permissible in the course of the proper use of the **MBRAUN** system.

- ▶ Please heed the information about the safety concept in Chapter 3, Safety.

It is the customer's responsibility to determine the degree of risk of the applications and if necessary to install and apply additional safety equipment and functions.

- ▶ If necessary, a specific standard operating manual must be created for the conditions on-site.

8.7 Additional functions and box equipment (optional)

8.7.1 Additional box equipment (optional)

Designation	Function	Separate document item Nr.	See Chap.
	Box atmosphere:		
Particle absorber <i>(various service areas)</i>	Suctioning of particles from processing in the box	misc.	10 A .. ff
Differential pressure sensor	Monitoring of the degree of saturation of the particle filter	Supplier documentation	15
UGP	Universal measurement device for various gases/solvent vapours		10 A..ff
GSU	Determination of a specific gas mixture (H ₂ O/ O ₂)		10 A..ff
Quick-purge function	For large-volume boxes/multi-box systems: speeding up of the purging of the box		8 A ..ff
	Box temperature		
Box cooling RKI 80-200-300	Cooling of the box atmosphere		8 C
	Cooling/heating of process materials		
Refrigerator/externally-mounted cooling container	Cooling of process materials		10 A.. ff
Vacuum dry cabinet VC20	Drying of process materials in a vacuum	Supplier documentation	15
	Cooling of additional equipment		
Circulation cooler	Cooling of process heat / additional equipment in the box		
	Additional equipment for processes in the box		
Spincoater MB-SC-200	Coating processes semi-conductors - (turning)		10 A.. ff
<i>Evaporation systems</i>	Evaporation of substances on a carrier		10 A.. ff
<i>Multi-box systems</i>	Allow operation with various processes		8 B

Additional functions and box equipment (optional)

8.7.2 Box safety equipment (optional)

Designation	Function	Document item No.	See Chap.
Over pressure safety valve MB-OSV	Securing of the box pressure; tear securing of the gloves		8 A
Light barrier/curtain	Reach-in guard against moving parts in the box	Supplier documentation	8 A ..ff
UV protection pane	Protection against UV radiation		8 A.. ff
Box purge from external source	For securing inert gas operation in case of error of the circulation operation		8.5.6

8 A.1 Oxygen Analyzer MB OX-SE-1	2
8 A.1.1 <i>Design overview</i>	2
8 A.1.2 <i>Technical Data</i>	3
8 A.1.3 <i>Connection</i>	3
8 A.2 Moisture Analyzer MB MO-SE-1	4
8 A.2.1 <i>Design overview</i>	4
8 A.2.2 <i>Technical Data</i>	4
8 A.2.3 <i>Connection</i>	5
8 A.3 Calibration of measurements	5

Oxygen Analyzer MB OX-SE-1

8 A Analyzer (Optional)

Applies to systems with optional H₂O and/or O₂ analyzers:

The following analyzers can be used with the system:



Oxygen analyzer **MB-OX-SE-1**



Moisture analyzer **MB MO-SE-1**

8 A.1 Oxygen Analyzer MB OX-SE-1

The MB-OX-SE-1 sensor is designed to control the atmosphere of **M BRAUN** Systems for residual Oxygen content. The measuring range is 0 to 1000 ppm. The measuring range from 0 – 100 ppm is linear.

The semiconductor sensor made of Zirconium dioxide is specific for oxygen, but because of the high sensor temperature and the catalytic activity of the platinum electrodes of the sensor there are low cross-sensitivities for hydrogen as well as possible reactions with aggressive gaseous substances, that can reduce the operational life of the sensor.

! Operating the sensor at oxygen levels of >1000 ppm (e.g. in air) does not damage the sensor element irreversibly, but it should be avoided. If exposed to air, it will take several hours until the sensor will measure low oxygen levels correctly in Inert Gas.

8 A.1.1 Design overview

The MB-OX-SE1 consists of the sensor and a box with integrated electronics and a gas-tight DN40-KF clamp flange. The sensor is protected by a protective cage against mechanical damage. The sensor leads are connected to the electronics by a vacuum-tight feed-through. The electronics are contained in an airtight box mounted directly behind the DN40-KF flange.

The electronic measuring equipment is supplied with 24 VDC. It provides a voltage signal of 0-10 VDC proportional to the oxygen concentration.

Via an additional input, the heater of the sensor element is controlled. If the external input is not used, a jumper has to be set at the electronics.

8 A.1.2 Technical Data

Mechanical	Length over all:	190 mm, height 80 mm, depth 58 mm
	Sensor-part:	length 45 mm, diameter 26 mm
	Flange:	NW 40 KF
	Weight:	0.7 kg
Electrical	Supply voltage:	24 VDC \pm 10%
Environment	Ambient temperature:	+15 to +27 °C
	Pressure:	800 to 1200 mbar (Differential pressure sensor to electronics max. \approx 200 mbar)
Measuring	Range:	0 - 1000 ppm oxygen
	Sensitivity:	10 mV / ppm
	Response time (0 - 90 %):	approx.. 10 sec (0 - 90 %)
	Warm-up time:	10 min (for < 10 ppm approx. 6 hr)
	Accuracy ¹⁾ :	2 % of displayed value \pm 1 ppm
	Drift at 10 ppm:	< 10 % / year
	Sensor life ²⁾ :	ca. 5 years

- 1) In clean argon-atmosphere, without interfering gases like H₂O or CO₂
- 2) In absence of reactive gases (contact MBRAUN Service for further advice)

8 A.1.3 Connection

The connection for the Oxygen Sensor is made with an RJ45 (8-pole) Socket Connector. The pin layout is shown in the table below.

Pin-No.	Contact
1	Supply Ground
2	Switching ON/OFF 24 V
3	Signal Ground
4	Lifebit (O ₂)
5	Not Connected
6	Signal 0 - +10 V
7	Supply +24 V
8	Supply Ground

Moisture Analyzer (MB MO-SE-1)

8 A.2 Moisture Analyzer (MB MO-SE-1)

The MB-MO-SE1 is designed to control the atmosphere of the **MBRAUN** Systems for residual moisture content. The measuring range is 0 to 500 ppm. The measuring range from 0 – 50 ppm is linear. Above 500 ppm it is possible to make an estimation of the moisture content of the inert gas atmosphere.

The sensor element is made of specifically printed ceramic. The sensor is coated with totally dehydrated phosphoric acid. Water molecules in the gas are absorbed at the phosphoric acid. The electric current of the sensor electrodes separate the water molecules (electrolysis) into H₂ and O₂.

The flowing current is a directly measurement for water vapor partial pressure of the measuring gas. The primary signal is amplified and temperature compensated indicated.

8 A.2.1 Design overview

The moisture analyzer MB-MO-SE1 consists of the sensor element and a special electronics unit. The sensor is protected by a protective cage against mechanical damage. The sensor leads are connected to the electronics by a vacuum-tight feed-through. The electronics are contained in an airtight box mounted directly to the back of the DN40-KF flange.

Electronics and Sensor Element have been factory-calibrated with certified calibration gases; there are no user-accessible adjustment points.

8 A.2.2 Technical Data

Mechanical	Length over all:	205 mm, height 80 mm, depth 58 mm
	Sensor-part:	length 42 mm, diameter 14 mm
	Flange:	DN 40 KF
	Weight:	0.7 kg
	Electrical Supply voltage:	24 VDC ±10%
Environment	Ambient temperature:	+15 to +27 °C
	Pressure:	800 to 1200 mbar (Differential pressure sensor to electronics max. ≈200 mbar)
Measuring	Range:	0 - 500 ppm moisture
	Sensitivity:	20 mV / ppm
	Response time (0 - 90 %):	approximately 120 sec. (0 - 90 %)
	Warm-up time:	10 min (for < 10 ppm approx. 6 hr)
	Accuracy ¹⁾ :	
	High precision range (0 - 10 ppm):	better than 5 % of value
	Wide range (10 - 100 ppm):	better than 20 % of value
	Drift at 10 ppm	< 10% / year
	Sensor life ²⁾ :	ca. 5 years

1) without interfering gases like NH₃

2) with regular maintenance

8 A.2.3 Connection

The connection for the Moisture Sensor is made with an RJ45 (8-pole) Socket Connector. The pin layout is shown in the table below.

Pin-No.	Contact
1	Supply Ground
2	Switching ON/OFF 24 V
3	Signal Ground
4	Not Connected
5	Live bit (H2O)
6	Signal 0 - +10 V
7	Supply +24 V
8	Supply Ground

8 A.3 Calibration of measurements

As default, **MBRAUN**-measurements are calibrated before delivering.

- ! It is recommended to calibrate the measurements yearly by **MBRAUN**-specialists. Please, contact the service of **MBRAUN**.

In case of dysfunction, send the measurement unopened and complete to the service of **MBRAUN**.

On request, analyzers are available as return parts. Ask **MBRAUN**.

Using Oxygen and moisture analyzer: see chapter Inertgas box.

Cleaning moisture sensors: see chapter 12, Inspection and maintenance

9.1	Introduction	9-2
9.1.1	<i>Basic rules.....</i>	9-2
9.2	Safe antechamber processes.....	9-3
9.2.1	<i>Antechamber doors and antechamber atmosphere</i>	9-5
9.3	Operating the vacuum pump, antechamber doors and tray	9-6
9.3.1	<i>Notes about the vacuum pump</i>	9-6
9.3.2	<i>Notes for the door operation.....</i>	9-7
9.3.3	<i>Operation of mini-antechamber.....</i>	9-8
9.3.4	<i>Operating doors on the round antechamber.....</i>	9-9
9.3.5	<i>Operating locking of the antechamber doors (optional).....</i>	9-10
9.3.6	<i>Loading antechamber tray.....</i>	9-11
9.4	Antechamber processes: manual operation	9-12
9.4.1	<i>Loading into the box using the example mini-antechamber</i>	9-12
9.4.2	<i>Unloading material from the box</i>	9-14
9.5	Antechamber processes: PLC-controlled	9-16
9.5.1	<i>Overview of antechamber screens</i>	9-16
9.5.2	<i>Description of antechamber screens</i>	9-17
9.5.3	<i>Transfer in.....</i>	9-21
9.5.4	<i>Transfer out.....</i>	9-25
9.6	Additional equipment and functions (optional)	9-26
9.6.1	<i>Additional functions</i>	9-26
9.6.2	<i>Additional equipment.....</i>	9-26

9 Operation of the Antechamber

The structure and functions of the antechamber are described in Chapter 2 System components.
See *Chap. 2.4*.

9.1 Introduction

This operating manual describes the safe handling of antechamber processes.

- *Chapter 9.3* shows the mechanical operation aspects of vacuum pump, door locking and antechamber tray.
- The manual operation of an antechamber process is depicted in exemplary fashion in *Chap. 9.4* using the mini-antechamber (150 mm) for the understanding of the principle of an antechamber process.
- *Chap. 9.5* shows the operation of PLC-controlled antechamber processes using the touch panel.
- *Chap. 9.6* provides an overview of optional additional equipment and functions.

9.1.1 Basic rules

The quality and degree of safety of the antechamber processes depend on adherence to the operating steps described in this operating manual and the type of process materials used.

Basic rules for performing antechamber processes

- ▶ Always ensure good ventilation of the room
- ▶ Never open the inner and outer antechamber doors at the same time

Before opening the inner antechamber door:

- ▶ Equalize the antechamber atmosphere to the inert box atmosphere:
Always perform the required evacuation and refilling cycles and follow the action instructions for performing antechamber processes.



Always follow the specific safety instructions in *Chap. 9.2*.

9.2 Safe antechamber processes

Standard systems for product protection

Standard antechamber processes are designed for product protection for normal operating conditions with use of process materials in category 0 or 1 (see *Chapter 3 Safety concept and proper use*).

Use of hazardous process materials (category IV and EX)

If processes/process materials with specific risks are used,

- that are sensitive, toxic or very flammable
- or emit in some other way (such as radioactivity)

In these cases, additional safety equipment and/or functions for antechamber processes are required.

- ▶ Follow the instructions in the basic safety chapter for the classification and evaluation of substances (Chapter 3).
- ▶ If necessary, ensure the use of the required additional equipment!
- ▶ In case of questions, please contact **MBRAUN SERVICE**.

Antechamber processes



CAUTION

Incorrect operation of the antechamber processes can compromise the health of the operator. The oxygen of the ambient air can damage process material.

- ▶ Always follow the instructions in this operating manual
 - ▶ If necessary, use additional safety equipment and functions and personal protective equipment (PPE)
 - ▶ If necessary, follow your operation-specific standard flow plan
-

Safe antechamber processes

Transport containers



WARNING

Risk of explosion or implosion from transport containers that are not vacuum-suitable. Depending on the process materials used, there can be additional risks for people.

- ▶ With transport containers with gas-like or liquid content (e.g. bottles and containers): note that they must stand up to the pressure changes during evacuation/refilling of the antechamber
- ▶ Do not evacuate liquids below their vapour pressure at the given temperature.
- ▶ If necessary, use vacuum-suitable transport containers.

NOTICE

Ambient air trapped in transport containers causes contamination of the box atmosphere.

There can be damage to process materials, which depending on the type of materials can cause unexpected risks.

- ▶ Open closed containers (boxes, bottles, etc.) – insofar as possible – before loading
 - ▶ Always provide transport containers with required stickers and warning labels.
-

9.2.1 Antechamber doors and antechamber atmosphere

9.2.1.1 Loading

NOTICE

Oxygen and moisture in the ambient air contaminate the box atmosphere and can trigger unexpected reactions and do damage to process materials. Measurement instruments can be damaged.

- ▶ Adhere to on-site conditions
- ▶ Never open the inner and outer antechamber doors at the same time
- ▶ Never open the inner antechamber door if the antechamber is filled with ambient air.

Before opening the antechamber inner door:

- ▶ Always match the antechamber atmosphere to the highly-pure atmosphere in the box through several cycles of evacuation/refilling of the antechamber with working gas.
-

9.2.1.2 Unloading

Unloading cycle in standard systems:

After closing the inner antechamber door, the outer antechamber door can be opened. The inert box atmosphere that has penetrated the mini- and round antechambers may escape into the room (see section 9.4.2).

Please note: Only allowed with the use of non-toxic gases and process materials! (See Chap. 3 Safety).

9.2.1.3 After completing an antechamber process



WARNING

Health hazard and/or risk to process materials in case of open antechamber doors.

After completing an antechamber process:

- ▶ Always make sure that the outer and inner door of the antechamber are closed.
-

Operating the vacuum pump, antechamber doors and tray

9.3 Operating the vacuum pump, antechamber doors and tray

Before the operation of the antechamber processes is described, this section provides an overview of prerequisites for operation of the vacuum antechamber, the antechamber doors and the antechamber tray.

9.3.1 Notes about the vacuum pump

Exhaust / exhaust air

MBRAUN recommends connecting the exhaust system of the vacuum pump to an in-house exhaust system.

Switching on/off

Before starting the antechamber processes

- Switch on the vacuum pump

System with a single vacuum pump (VPG)

The vacuum pump is primarily used for box pressure regulation, its second priority is for evacuation processes of the antechamber (*cf. Section 9.5 PLC-controlled antechamber processes*).

In case of very frequent antechamber processes, **MBRAUN** recommends using a separate vacuum pump for antechamber processes.

System with a separate vacuum pump for antechamber processes (VP)

If the vacuum pump is no longer needed:

- ▶ Switch off vacuum pump on the touch panel → The pump is switched on again automatically for the next evacuation/refill cycle.

2-antechamber system and VP

If two antechambers use a single vacuum pump:

Only one of the antechambers at a time can run through an automatic cycle or be evacuated manually. The first activated antechamber takes priority.

ECO-Mode (optional)

in ECO-Mode the vacuum pump is switched down at a defined point in time. *See special chapter 6 A (optional).*

9.3.2 Notes for the door operation

Damage to the antechamber door in case of incorrect operation

An evacuated antechamber under vacuum cannot be opened. With an attempt to open an evacuated antechamber, the door locking mechanism can be damaged.

Door seals

Dirt, solvents and foreign bodies can damage the door seals and door mechanism.

Make sure that the door and the door seals are free of dirt and objects before you close the antechamber door.

Check the seals regularly to make sure they are tight

Risk of crushing in case of improper operation

Keep your hands away from the antechamber door area.

Operating the vacuum pump, antechamber doors and tray

9.3.3 Operation of mini-antechamber

9.3.3.1 Operating doors of the mini-antechamber

The mini-antechamber is equipped with a manually-activated lever locking mechanism.



Closed outer door:

- > Lever is locked in the bracket



Opening the outer door:

To open:

- ▶ Lift lever and pull out of the bracket
- ▶ Unfold cover

To close:

- ▶ Place the lever in the bracket and lock



Closed inner door

- > Lever is locked in the bracket



Opening the inner door

- ▶ Open and close as above.

9.3.4 Operating doors on the round antechamber

The door on the round antechamber is equipped with a gas pressure spring for lifting and lowering the antechamber door.

NOTICE

Material damage in case of improper handling!

- ▶ Perform the swivel movement of the doors for lifting/lower the doors without force
 - ▶ Do not overload the lifting mechanism
-



To open:

Prerequisite

- > Room is ventilated
 - > Antechamber is not under pressure
 - > Antechamber atmosphere is not contaminated
 - > Inner antechamber door is closed
- ▶ Turn rotary lock anti-clockwise until the door is completely unlocked.
 - ▶ Carefully swivel the antechamber door upwards:
 - ⇒ The antechamber bracket holds the door in the open position.



To close:

- ▶ Lower the door and position in front of the antechamber entrance.

Note

Activate rotary lock carefully. A too-strong overturning of the lock can damage the seals on the antechamber door.

- ▶ Turn the rotary lock clockwise until the door is locked.

Operating the vacuum pump, antechamber doors and tray

9.3.5 Operating locking of the antechamber doors (optional)

The antechamber can be equipped with an antechamber lock in order to prevent the simultaneous opening of the inner and outer doors.

-
- !** Before opening the antechamber door:
Make sure that the lock is released before you try to open an antechamber door.
-

Locked antechamber door

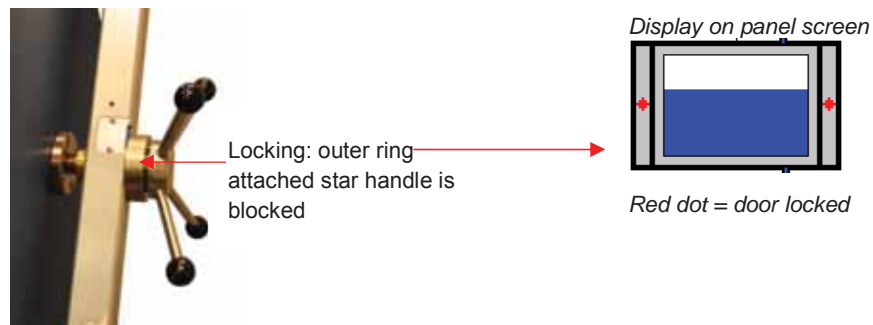

Released antechamber door

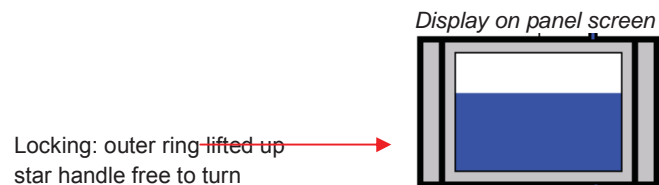

9.3.6 Loading antechamber tray

Prerequisites

Loading:	>	Inner door is closed	▶	Open outer door
Unloading:	>	Outer door is closed	▶	Open inner door

Material preparation

- ▶ Make sure that the packaging/containers are vacuum-suitable
- ▶ If necessary, place material in vacuum-suitable containers that can be sealed
- ▶ Open closed containers (boxes, bottles, etc.) – insofar as possible – before loading







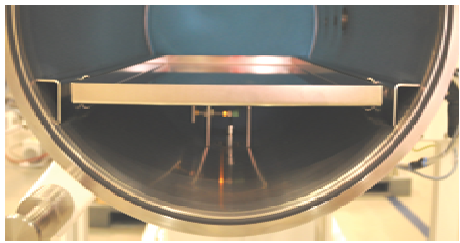

Loading

- | | |
|---------------------------------|---|
| <p>If no tray is available:</p> | <ul style="list-style-type: none"> ▶ Bring the material directly into the antechamber ▶ Make sure that no foreign bodies prevent the closing of the antechamber door <p><i>Loading:</i></p> <ul style="list-style-type: none"> ▶ Close the outer door of the antechamber. <p><i>Unloading:</i></p> <ul style="list-style-type: none"> ▶ Close the inner door of the antechamber. ▶ Start the antechamber process (see below) |
|---------------------------------|---|

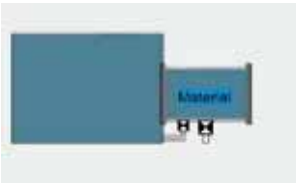
- | | |
|---|---|
| <p>If a tray is available: procedure as before and:</p> | <ul style="list-style-type: none"> ▶ remove tray, place material on it, then push tray plus material into the antechamber. |
|---|---|

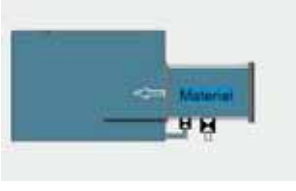

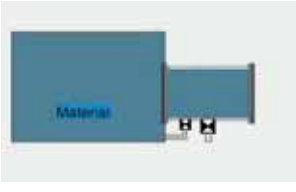
Optional for pneumatic doors:
 Sensor below the tray is activated if the tray is pushed into the starting position → Door mechanism is released
 Regard the activation light.









Step	Status of doors	Status of atmosphere of box / antechamber (AC)	Status antechamber pressure	Status manual valve	Action	Fig Mini-antechamber
6	Inside CLOSED Outside CLOSED		Change vacuum/ atm. flipEnd: = box pressure		Evacuate / refill Repeat several times until antechamber is inert - 150 Mini-antechamber: 2x - 390 Main antechamber: 3x	
7	Inside CLOSED Outside CLOSED		= Box pressure	 CLOSED	Close valve	
8	Inside OPEN Outside CLOSED		= Box pressure	 CLOSED	- Unlock inner door - Open inner door - Insert material from the antechamber into the box - Close inner door	
9	Inside CLOSED Outside CLOSED		= Box pressure	 CLOSED	./. The material is loaded	

Antechamber processes: manual operation

9.4.2 Unloading material from the box

! If the outer antechamber door was open, the inner walls may be moist. To prevent this, **MBRAUN** recommends performing an evacuation and refilling procedure after opening the outer antechamber door.

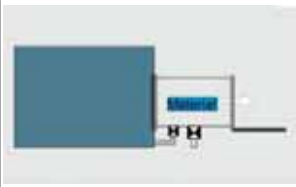
Step	Status of doors	Status of atmosphere	Status antechamber pressure	Status manual valve	Action	Example of mini-antechamber
1	Inner door CLOSED Outer door CLOSED		check whether = Box pressure	CLOSED	Check: is the antechamber inert? – No → step 2 Yes → step 3	
(2)	Inner door CLOSED Outer door CLOSED	 <i>optional if antechamber atmosphere is not inert</i>	Vacuum / Box pressure final: = Box pressure		<i>Evacuate / refill</i> Repeat several times until the antechamber atmosphere matches the box atmosphere (it is inert) - 150 Mini-antechamber: 2x - 390 Main antechamber: 3x	
3	Outer door CLOSED Inner door CLOSED		= Box pressure	CLOSED	- / - The antechamber is inert: - Open inner door	
4	Outer door CLOSED Inner door OPEN		= Box pressure	CLOSED	- Place material in the antechamber - Close inner door	
5	Inner door CLOSED Outer door CLOSED		= Box pressure	CLOSED	<i>Optional:</i> Perform step (6) – Standard: continue with step 7	

Step	Status of doors	Status of atmosphere	Status antechamber pressure	Status manual valve	Action	Example of mini-antechamber
(6)	Inner door CLOSED Outer door CLOSED	Optional: Refill with ambient air 	= Box pressure	 CLOSED	<i>if necessary, evacuate/refill with ambient air</i>  /  End: = atmosphere pressure	
7	Inner door CLOSED Outer door CLOSED	 <i>Standard</i>	= Atm. pressure		- Open outer door	
8	Inner door CLOSED Outer door OPEN		= Atm. pressure	 CLOSED	- Remove material from the antechamber - Close outer antechamber door	

Antechamber processes: PLC-controlled

9.5 Antechamber processes: PLC-controlled

9.5.1 Overview of antechamber screens

Antechamber 1 screen

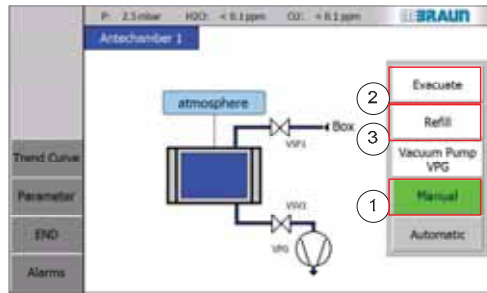

01601-1

Example: antechamber in manual operation

- (1) Manual operation with functions
- (2) Evacuation
- (3) Refilling

Antechamber 1 screen

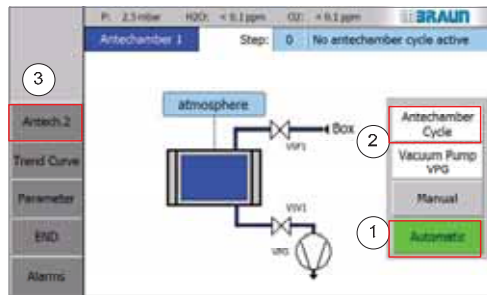

01601-2

Optional automatic operation:

- (1) **Automatic**
- (2) Function **Antechamber Cycle**
- (3) Second Antechamber: call up with navigation button **Antech. 2**

Antechamber 1 Parameters screen

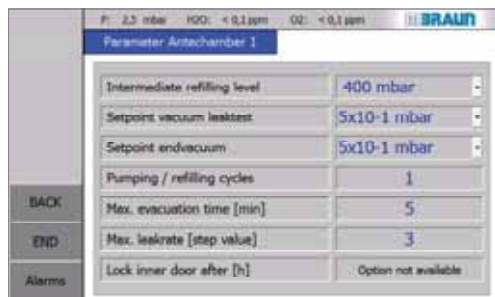

01600-1

After touching the button

Parameter

Parameter adjustments for automatic operation

Antechamber 1 Trend Curve screen

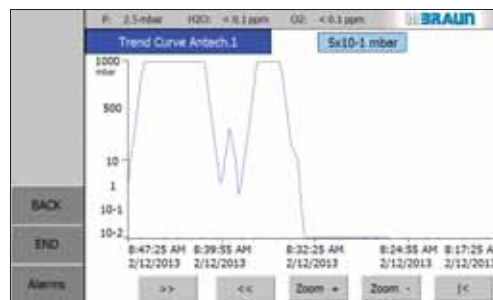

01602

Navigation: Antechamber 1 screen:

Call up trend curve

- Touch navigation button **Trend Curve**

9.5.2 Description of antechamber screens

9.5.2.1 Antechamber screen

The antechamber screen indicates the status of the antechamber processes.

The antechamber processes are activated and deactivated with the function keys

Antechamber 1 screen

01601-2

Example: automatic operation (optional)

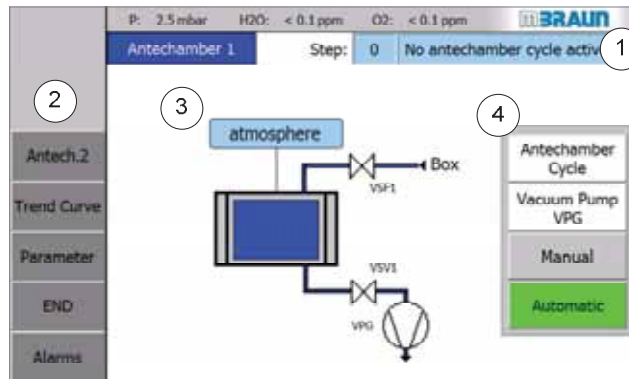

- (1) Status line
- (2) Navigation buttons
- (3) Display pictogram
- (4) Function button field

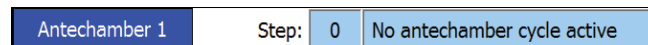

- (1) Status line

Only in the automatic antechamber process:

Display of the steps in the automatic antechamber process



- Key calls up the "Antechamber 2" screen (for systems with 2 antechambers)
- Button calls up the "Trend Curve" screen (see 9.5.2.3)
- Button calls up the "Parameters" screen (see 9.5.2.2)
- back to the "Start screen"

- (2) Navigation

The pressure of the automatic antechamber is measured with pressure sensors.

The current value is displayed in the light blue field:

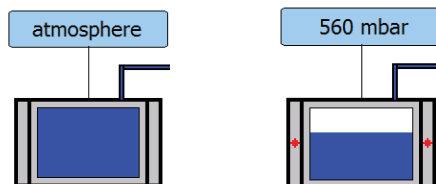

- (3) Pictograms: pressure indicator

The antechamber pressure is displayed graphically as a blue bar: the lower the pressure in the antechamber, the lower the bar height.

Note:
If the system is equipped with just one manometer, no values appear on the touch panel

Antechamber processes: PLC-controlled

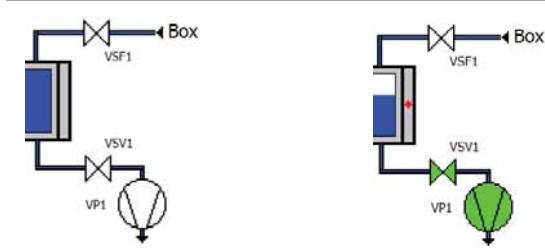

Cont. (3)

Status indicator

- Valves (input/output)

- Vacuum pump

The antechamber processes are activated/deactivated with the function buttons.

(4) Function button/antechamber status indicator field

Evacuate	In manual operation: evacuation of the antechamber function
Refill	In manual operation: refilling of the antechamber function
Antechamber Cycle	In automatic operation: Antechamber cycle function: Automatic flow of the evacuate/refill cycle
Change between the modes: Manual operation and automatic operation	
Manual	In manual operation: release of the evacuate – refill buttons
Automatic	In automatic operation: release of the "Antechamber cycle" button
Vacuum Pump VPG	Vacuum pump <i>Here: vacuum pump gas purifier</i> <i>Optional: additional pump VP</i>

9.5.2.2 Antechamber parameters

Antechamber 1 Parameters

01600-1

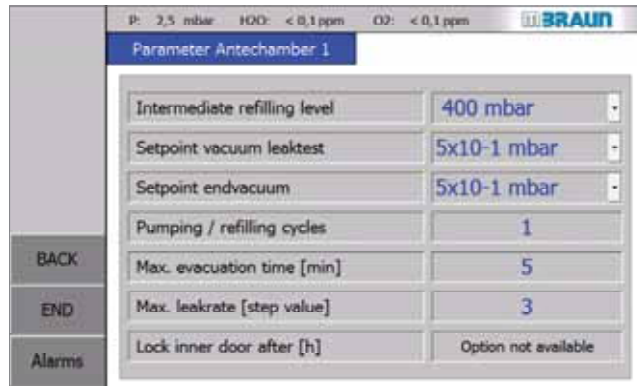

Automatic antechamber parameters

Optional: display of parameters locking of inner door

The parameters are pre-set by **MBRAUN** and can be adapted if necessary.

Parameters for the antechamber cycle evacuate + refill

Description	MBRAUN setting	Unit			Customer setting	
			min	max	min	max
Threshold value intermediate refill Value for the pressure up to which the antechamber is filled between two evacuation steps.	400	mbar	1x10-2	50		
Threshold value vacuum leak test Target value for the vacuum leak test.	5x10-1	mbar	1x10-2	10		
Threshold value final vacuum Target value for the pressure at which the evacuation ends.	5x10-1	mbar	1x10-2	10		
Number of pump refill cycles Number of pump evacuation/refill cycles	1	X	1	10		
Maximum evacuation time [min] Period in which the value for "Threshold value vacuum leak test" must be reached. In case of error, the cycle is stopped and the message "Time exceeded" appears.	5		1	10		

Antechamber processes: PLC-controlled

Description	MBRAUN setting	Unit			Customer setting	
			min	max	min	max
<p>Maximum leakage rate [steps]</p> <p>Value for the maximum permissible pressure increase during the two steps of the vacuum leak tightness test in a defined time period.</p> <p>Example: 2×10^{-1} mbar to 4×10^{-1} mbar If the parameter value is reached, the process is stopped and the message "Antechamber leaks" is displayed.</p>	3		1	10		
<p>Lock inner door after [h]</p> <p>Optional for cover locking: if the antechamber is not used for a longer time, the inner door can be locked after an adjustable time in order to secure the purity of the box atmosphere.</p>	Default: 60 Value 0 = function deactivated	H	1..	999		

9.5.2.3 Trend displays for the antechamber

The trend display represents the pressure of the antechamber over the course of time.

Antechamber 1 Trend Curves

01602

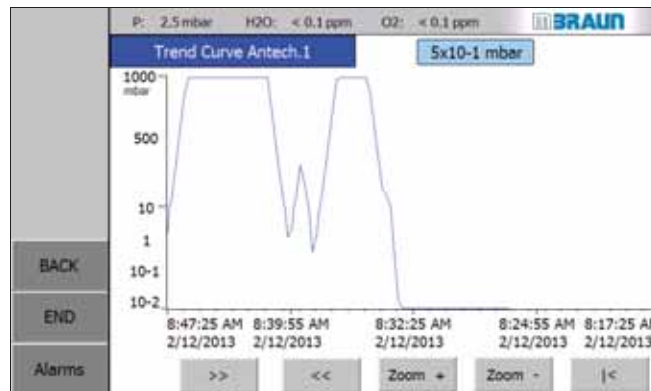

Optional: Trend curve temperature; activated via "Temperature" navigation button

9.5.3 Transfer in

9.5.3.1 Preparations

The antechamber atmosphere is prepared for the loading and unloading of materials through evacuation and refilling with inert gas and ambient air. Parameters are pre-set for the PLC-controlled processes (see above). The processes are activated on the touch panel

9.5.3.2 Manual operation: evacuation and refilling

The antechamber functions "evacuation" and "refilling" are started and stopped manually with a button on the touch panel.



The antechamber pressure is displayed on the manometer on the antechamber. During the evacuation and refilling process:

- ▶ Observe antechamber pressure

End pressure refilling: 200-400 mbar
 End pressure evacuation: < 1 mbar
 End pressure: Box pressure

Prerequisite

Antechamber doors > Both antechamber doors are closed

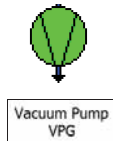

The vacuum pump is switched on automatically at the evacuation start.

With an additional vacuum pump:

If necessary switch on: on Functions 2 or Antechamber 1 screen

- ▶ Touch button Vacuum pump VPG



Activate "manual operation" operating mode

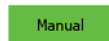

- ▶ Touch button Manual
- The colour of the button changes from GREY to GREEN
- The Evacuate and Refill buttons are released

Antechamber processes: PLC-controlled

Antechamber 1 - manual operation screen

01601-1

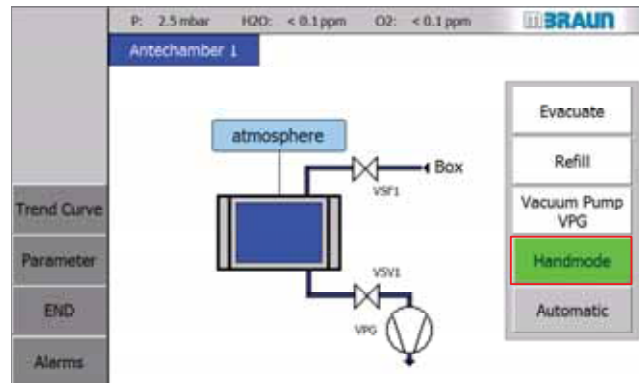
**Status:**

Manual operation switched on:

- The "Evacuate" and "Refill" buttons are released
- The automatic mode is locked

Evacuation and refilling cycle:

To evacuate:

- ▶ Touch button
- ▶ Evacuate until antechamber pressure < 1 mbar

To refill:

- ▶ Touch button
- ▶ Intermediate refilling up to antechamber pressure 200 .. 400 mbar

Repeat 3 x:

Evacuate cycle -- execute refilling 3 x

Then:

- ▶ Refill up to box pressure
- ▶ Close refill valve: touch button again

Door operation after evacuation -- refilling

After completing the evacuation and refill process and reaching the target pressure, one door apiece (inside or outside) can be opened.

When loading:

- > Reaching of the box pressure: ▶ Open inner door

When unloading

- > Atmosphere pressure: ▶ Open outer door

Please note:



The refilling of the antechamber in manual operation is limited to 10 minutes; after that, the function switches off automatically.

- the "Refill" function can be switched on again
- the "Automatic operation" function can be switched on

9.5.3.3 Automatic antechamber cycle (Option)

The automatic antechamber cycle with evacuation and refilling is defined by the parameters.

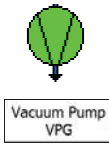
Prerequisite

Antechamber doors	> Both antechamber doors are closed
	<p>The vacuum pump is switched on automatically at the start of the antechamber cycle.</p> <p>With an additional vacuum pump:</p> <p>If necessary switch on: on Functions 2 or Antechamber 1 screen</p> <ul style="list-style-type: none"> ▶ Touch button Vacuum pump VPG
	<p>Activating "automatic" operating mode</p> <ul style="list-style-type: none"> ▶ Touch button Automatic → The colour of the button changes from GREY to GREEN → Thus the "Antechamber cycle" button is released

Automatic antechamber cycle:

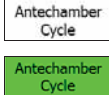
	<p>Start of the automatic antechamber cycle:</p> <ul style="list-style-type: none"> ▶ Touch button Antechamber cycle
---	---

Antechamber 1 – automatic operation

01601-3

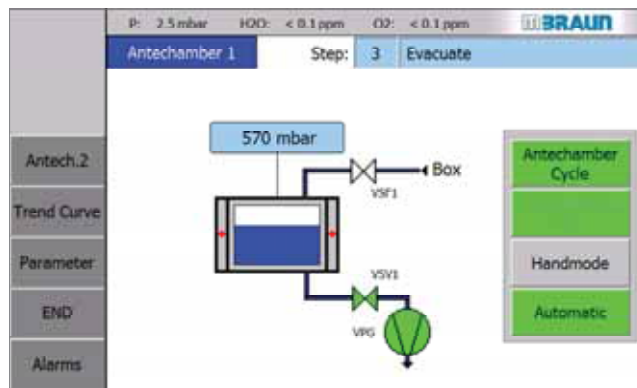

Status: automatic operation switched on

- The pre-set number of evacuation and refilling cycles is run through automatically.
- The vacuum pump is activated and cannot be switched off

Antechamber processes: PLC-controlled

Operation of the antechamber doors (standard)

Standard systems:

After completing an antechamber cycle, both antechamber doors are released.

Equipment with automatic door locking (optional):

After run-through of a complete antechamber cycle:

- both antechamber doors are released –
- however only one of the two doors can be opened:

After opening the outside doors

- the inside door is locked
- only after another run-through of a complete antechamber cycle:
- release of the inside door

After closing the inside door

- both doors are released for opening

(see also section 9.6.1 Automatic cover locking).



Inner door locking

If the antechamber is not used for a longer time, a pure antechamber atmosphere is no longer guaranteed. Therefore, the inner door can be locked after a particular time (see *Chap. 9.5.2.2: Parameters for inner door locking*).

Before release of the door, the pre-set number of antechamber cycles is run through.



Pressure disturbances

In case of box pressure disturbances or disturbances of the antechamber pressure, please observe *Chapter 11 Troubleshooting*.

9.5.4 Transfer out

Flow unloading of material		
1	Antechamber doors	> Both antechamber doors are closed
2	Antechamber atmosphere	> The antechamber is filled with inert gas > Antechamber pressure and box pressure are the same
3	Inner antechamber door	> The antechamber door is released / can be opened
4	Loading antechambers	▶ Load the antechamber from the box with material
5	Inner antechamber door	▶ Close the inner antechamber door
6	Antechamber atmosphere	In case of contaminated box atmosphere: ▶ Evacuate antechamber / refill (manual operation or automatic - see above) <i>optional: refill with ambient air</i> → End pressure: atmosphere
7	Outer antechamber door	→ The antechamber door is released / can be opened
8	Antechamber loading	▶ Remove material from the antechamber from the outside ▶ If necessary, reload
9	Outer antechamber door	▶ Close

Additional equipment and functions (optional)

9.6 Additional equipment and functions (optional)

9.6.1 Additional functions

Equipment	Function	see Chap.
Refill the antechamber with inert gas from external source*) Note: *) This always requires an additional safety pressure control valve on the antechamber!	<ul style="list-style-type: none"> ▪ To speed up antechamber processes: for large antechambers, whose inner volume is not a lot smaller than that of an inert gas box. ▪ If the antechamber should not be flooded with contaminated box atmosphere (e.g. in case of the use of solvents or special gases in the box). This always requires 	9 A ff
Purging of the antechamber in over pressure (= purge antechamber)	Inertising of the antechamber for use of vacuum-sensitive materials	9 A ff
Refilling of the antechamber with ambient air (unloading)	For large antechambers; with the use of gases and/or process materials that are hazardous to health/the environment	9 A ff

9.6.2 Additional equipment

Equipment	Function	see Chap.
Door locking	Prevents the simultaneous opening of inside and outside doors of the antechamber	9.5.3.3
2-antechamber operation	Allows directed production flows in the box / if necessary, different conditions (e.g. vacuum antechamber and purge antechamber)	9.5.1 / 9.5.2
T-antechamber	Transfers of process materials in multi-box operation (box to box; box-outside)	9 A ff
Button operation	Antechambers can (also) be equipped with external button operation (e.g. T-antechamber or 2-antechamber operation)	9 A ff
Antechamber oven	Heating up of process materials under vacuum	10 A ff

10.1 Safety	10-2
10.2 MBRAUN additional equipment	10-3
10.2.1 <i>Additional equipment box</i>	10-3
10.2.2 <i>Additional equipment antechamber</i>	10-6
10.3 Customer-specific components	10-7
10.4 Other manufacturers' components	10-7

Safety

10 Additional equipment (optional)

Additional equipment can be integrated into a **MBRAUN** standard system:

- **MBRAUN** additional components
- Other manufacturers' additional components
- Customer-specific components

These can be used to create solutions for customer-specific processes.

10.1 Safety

Proper Use / Misuse

Proper use / misuse are described in the specific additional chapters. Please follow the instructions there.

Emergency OFF

If components are integrated into the **MBRAUN** system and equipped with an EMERGENCY OFF switch, please follow the note below:



DANGER

Personal injury and environmental damage due to incorrect operation!

EMERGENCY OFF buttons which are on third-party components only switch off the respective component!



- ▶ In case of danger, switch off the main switch on the system's control cabinet!
-





10.2 MBRAUN additional equipment

10.2.1 Additional equipment box

Designation	Function	Separate document item Nr.	See
Box atmosphere:			
 Particle absorber (various service areas)	<i>Suctioning of particles from processing in the box</i>	<i>misc.</i>	<i>Chap. 10</i>
Differential pressure sensor	<i>Monitoring of the degree of saturation of the particle filter</i>	<i>Equipment of third-party suppliers-</i>	<i>Chap. 14</i>
 UGP	<i>Universal measurement device for various gases/solvent vapours</i>	Contact MBRAUN Service	<i>Chap. 10</i>
 GSU	<i>Determination of a specific gas mixture (H₂O/ O₂)</i>	1600664	<i>Chap. 10</i>
 Oxygen sensors	<i>Monitoring of oxygen content in the box atmosphere (ppm and % range)</i>	Contact MBRAUN Service	<i>Annex and Chap. 13</i>
 Moisture sensor	<i>Monitoring of the moisture content in the box and antechamber atmosphere</i>	1600685	<i>Annex and Chap. 13</i>
Use of solvents			

MBRAUN additional equipment

Designation	Function	Separate document item Nr.	See
 <p>Regulating LMF externally</p>	<p><i>Removing solvents</i></p> <p>Regulate LMF normally / internally for gas purification or</p> <p>Regulate LMF with hand valves externally for gas purification for retrofitting in the frame of the box</p>		Chap. 10 A ff
Multi-box systems	Allows operation with different processes with different quality of the box atmosphere		Chap. 10
Box temperature			
 <p>Box cooling RKI 80-200-300</p>	<p><i>Cooling of the box atmosphere</i></p>	1600328	Chap. 10 A ff and Chap. 15
Handling process materials			
 <p>Refrigerator</p>	<p><i>Cooling of process materials</i></p>		Chap. 10 A ff.
 <p>Cold Well</p>	<p><i>Cooling of process materials</i></p>		Chap. 10 A ff.

Designation	Function	Separate document item Nr.	See
 Vacuum-drying cabinet VC20	<i>Drying of process materials in a vacuum</i>	<i>Equipment of third-party suppliers-</i>	<i>Chap. 15</i>
Cooling of additional equipment			
 Circulation cooler	<i>Cooling of process heat / additional equipment in the box</i>	2801554	
Shelves in the box			
	<i>Storage areas for process materials</i>		
Additional equipment for processes in the box			
 Spincoater MB-SC-200	<i>Coating processes semi-conductor - (spinning)</i>	1604510	<i>other see Chap. 10</i>
Box protective equipment			
Over pressure safety valve MB-OSV	<i>Securing of the box pressure; tear securing of the gloves</i>		
Light curtain	<i>Reach-in guard against moving parts in the box</i>	<i>Third party equipment</i>	
UV protection pane	<i>Protection against UV radiation</i>		

MBRAUN additional equipment

10.2.2 Additional equipment antechamber

Designation	Function	Separate document item Nr.	See
Antechamber types			
 T-antechamber	In multi-box systems: Transfer processes between 2 boxes or between box and outside environment		Chap. 9 A ff.
 Oven antechamber 250°C stand-alone	Heating up of process materials under vacuum		Chap. 9 A ff.
Heatable mini-antechamber	Heating up of process materials under vacuum		Chap. 10 A ff.
 Oven antechamber VOH-600	Heating up of process materials under vacuum up to 600°C		Chap. 10 A ff.
Functions			
Purge antechamber	Transfers of vacuum-sensitive materials; Purging of the antechamber with inert gas / ambient air in over pressure		Chap. 9 A ff.

10.3 Customer-specific components

MBRAUN can integrate customer-specific components in inert gas systems. This way, customer-specific processes, special controller functions and safety requirements can be set up.

Special requirements and customer requests can be planned and implemented in consultation with the **MBRAUN** Service Department.



For the integration of customer-specific components/process systems into a standard inert gas system:

The responsibility for the safe handling of customer-specific processes lies with the customer, including the documentation and training of personnel.

10.4 Other manufacturers' components

MBRAUN inert gas systems can be equipped with components from third-party manufacturers, for example:

- Vacuum pump(s)
- Compressor(s) for system cooling
- Compressor(s) for freezers

The original supplier documentation is a component of the scope of delivery. *See Chap. 14 Supplier documentation*

MBRAUN assumes no liability for the content of the documentation of third-party manufacturers.

11.1 Eliminating faults (general/mechanical)	11-2
11.1.1 PLC	<i>Error! Bookmark not defined.</i>
11.1.2 Gas purifier	11-2
11.1.3 Box	11-2
11.1.4 Antechambers	11-4
11.2 Opto-acoustic alarm (optional)	11-5
11.3 Acknowledge/delete warning messages (PLC)	11-6
11.4 Definition of the alarm and warning messages (PLC)	11-7
11.5 Recommissioning after cancellation and power failure	11-17
11.5.1 Normal flow regeneration	11-17
11.5.2 Regeneration of the gas purifier RKM	11-17
11.5.3 Regeneration of the gas purifier LMF	11-18
11.6 Error search: leak test	11-18

Eliminating faults (general/mechanical)

11 Trouble shooting

11.1 Eliminating faults (general/mechanical)

11.1.1 PLC

Fault	Remedy	See Chap.
Start screen does not appear after switching on:	<ul style="list-style-type: none"> ▶ Check communication Panel + PLC- established? ▶ Check connector and electrical supply Fault not eliminated: <ul style="list-style-type: none"> ▶ Contact MBRAUN Service 	

11.1.2 Gas purifier

Fault	Remedy	See Chap.
See Error messages 11.4	See Error messages 11.4	Chap. 12

11.1.3 Box

Fault	Remedy	See Chap.
O2 and H2O values increase	<ul style="list-style-type: none"> ▶ Regeneration of the reactors necessary or switch over to the second reactor (if available) ▶ Perform leak test 	7.3.2
The O2 measurement value sinks very slowly to values below 10 ppm, although a greater purity of the box atmosphere must be assumed	Before an error in the measurement device is assumed: <ul style="list-style-type: none"> ▶ Check systems for disturbing influences: e.g. influences due to hydrogen or other gas components in the inert gas atmosphere, which cause increased indications. ▶ In case of a fault, send the device unopened and complete to MBRAUN Service. 	see 12.5.1.2 See separate documentation MB-OX-SE1

Fault	Remedy	See Chap.
Imprecise measurement values of the sensors	Note the duration until sensors work correctly: - O2 sensors: after exposure to air several hours -H2O sensors up to 24 hours.	See appendix, documentation MB-OX-SE1 + MB-MO-SE1
Pressure drop / pressure increase		
O2 / H2O increase		
Temperature increase / drop		
Glove tear *)	Securing with gloveport covers; eliminate cause; Perform glove change	Chap. 12.5.2
Inert gas / process material escapes into the environment	Leak	
Contamination of the box chemicals / dust ...	Clean box mechanically;	
Electrical faults / power failure		

***) Glove change in case of error - in case of leaky gloves and critical processes:**

1. In case of mechanical damage: initial securing with outer gloveport cover:
(**NOTICE:** Leave 1 feedthrough open!) - See Chap 12.
2. In case of pressure increase / drop: Eliminate cause - Take safety measures

If a quick glove change is required – (in order to prevent a contamination of the box or if hazardous materials should not get into the ambient air):

MBRAUN recommends the application of the glove change without gloveport cover method –

- ▶ Please follow the instructions in Chap. 12.

NOTICE

After an error, processes/process materials can be damaged!

- ▶ Proper disposal of unusable materials and defective gloves is the responsibility of the customer.
-

Eliminating faults (general/mechanical)

11.1.4 Antechambers

Event	Action	See Chap.
Power failure	For PLC-controlled antechambers:	
Unexpected pressure increase/drop	<ul style="list-style-type: none"> ▶ Check connections operating gas / purge gas / vacuum pump ▶ Check magnetic valves ▶ Check seals ▶ Leak test 	
Antechamber door mechanism blocked	<p>Do not use force to open! Risk of damaging the locking mechanism!</p> <p>In case of door locking:</p> <ul style="list-style-type: none"> ▶ Check on the panel: is the door locking released? <p>Vacuum in the antechamber?</p> <p>Release vacuum:</p> <ul style="list-style-type: none"> ▶ Remove KF40 cap on bottom or back of antechamber (depending on system configuration). 	

11.2 Opto-acoustic alarm (optional)

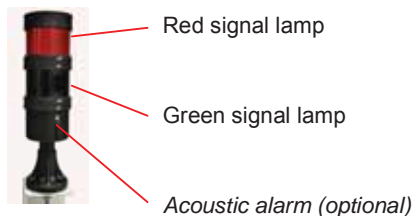

Every warning is indicated by an optical (and acoustic) signal:

Status	Description
Green light ON	Fault-free operation
Red light ON	Warning
Acoustic alarm	In addition for exceeding of values (optional: O2, H2O, box pressure...)

Switch off alarm: description in the following section:

Acknowledge/delete warning messages (PLC)

11.3 Acknowledge/delete warning messages (PLC)

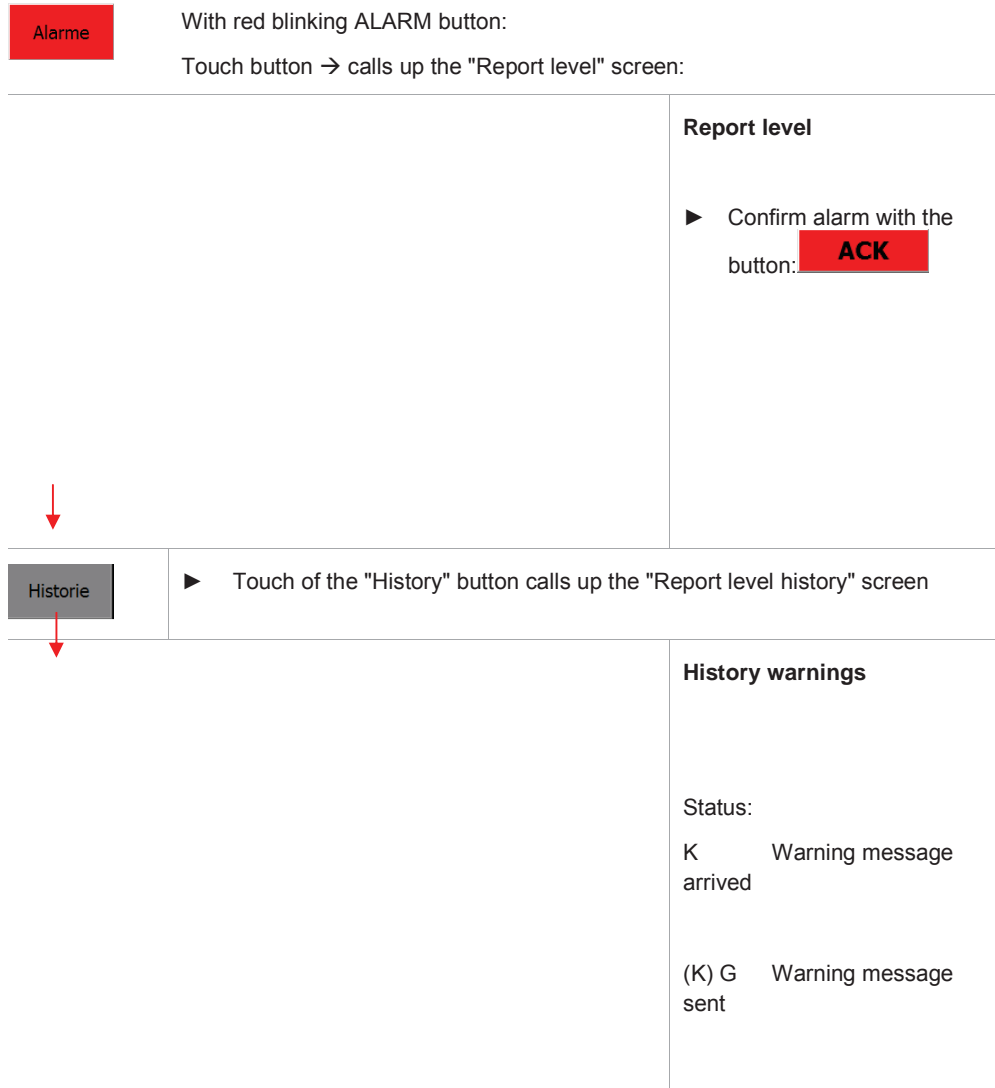

Deleting alarm and warning messages:

After eliminating the fault, delete the message in question:

Touch message: message is highlighted.

Touch **ACK** button: the selected message is deleted.

11.4 Definition of the alarm and warning messages (PLC)

Nr.	Description	Possible causes of faults	Solutions	How to eliminate / see Chapter
2	Motor guard vacuum pump VPG 1 has triggered	Vacuum pump defective Large leak in the vacuum tubing (vacuum pump is too heavily loaded by large leak)	Replace vacuum pump Eliminate large leak in the tubing Vacuum pump test	Test by MBRAUN Service
3	Circulation blower GB1 motor guard has triggered or fault in frequency converter.	Blower defective Stopping up of the filter / - blower tubing (therefore blower runs hot)	Replace blower Eliminate the stopping up of the blower tubing Blower test	Test by MBRAUN Service
4	Gas purifier: reactor 1 main valves not open	Main valve defective Control pressure too low	Replace main valve Set control pressure to 6 bar	
5	Gas purifier: reactor 1 main valves not closed	Main valve defective	Replace main valve Set control pressure to 6 bar	
6	Gas purifier: reactor 2 main valves not open	Main valve defective Control pressure too low	Replace main valve Set control pressure to 6 bar	
7	Gas purifier: reactor 2 main valves not closed	Main valve defective Control pressure too low	Replace main valve Set control pressure to 6 bar	
8	Gas purifier: no operating gas or pressure too low	Pressure monitor for operating gas set incorrectly or defective	Set operating gas pressure to 6 bar Set pressure monitor (approx. 5.5 bar) Replace pressure monitor	
9	Gas purifier: purge gas pressure too low	Pressure of purge gas too low Pressure monitor for purge gas set incorrectly or defective	Set purge gas to 6 bar Set pressure monitor (approx. 5.5 bar) Replace pressure monitor	

Definition of the alarm and warning messages (PLC)

Nr.	Description	Possible causes of faults	Solutions	How to eliminate / see Chapter
10	Gas purifier: purge valve VSPA not open	Purge valve output defective Control pressure too low	Replace purge valve output Set control pressure to 6 bar	
12	Gas purifier: securing in case of reactor heating	Reactor heater defective	Heater check	MBRAUN Service
33	LMF: main valve input-output filter 1 not open	Main valve solvent filter defective Control pressure too low	Replace main valve solvent filter Set control pressure to 6 bar	
34	LMF: main valve input-output filter 2 not open	Main valve solvent filter defective Control pressure too low	Replace main valve solvent filter Set control pressure to 6 bar	
35	LMF: main valve input-output filter 1 not closed	Main valve solvent filter defective	Replace main valve solvent filter	
36	LMF: main valve input-output filter 2 not closed	Main valve solvent filter defective Control pressure too low	Replace main valve solvent filter Set control pressure to 6 bar	
37	LMF: Bypass valve not open	Bypass valve solvent filter defective	Replace bypass valve solvent filter	
38	LMF: Bypass valve not closed	Valve plug unplugged Bypass valve solvent filter defective	Plug in valve plug Replace bypass valve solvent filter	
39	LMF: Motor guard vacuum pump has triggered	Vacuum pump defective Large leak in the vacuum tubing (vacuum pump is too heavily loaded by large leak)	Replace vacuum pump Eliminate large leak in the tubing Vacuum pump test	Test by MBRAUN Service
45	Motor guard vacuum pump VP1 has triggered	Vacuum pump defective Large leak in the vacuum tubing (vacuum pump is too heavily loaded by large leak)	Replace vacuum pump Eliminate large leak in the tubing Vacuum pump test	MBRAUN Service

Nr.	Description	Possible causes of faults	Solutions	How to eliminate / see Chapter
46	Motor guard vacuum pump VP2 has triggered	Vacuum pump defective Large leak in the vacuum tubing (vacuum pump is too heavily loaded by large leak)	Replace vacuum pump Eliminate large leak in the tubing Vacuum pump test by MBRAUN Service	MBRAUN Service
47	Motor guard vacuum pump VP3 has triggered	Vacuum pump defective Large leak in the vacuum tubing (vacuum pump is too heavily loaded by large leak)	Replace vacuum pump Eliminate large leak in the tubing Vacuum pump test	MBRAUN Service
49	Motor guard cooling compressor circulation has triggered	Cooling compressor for circulation defective	Compressor test Replace compressor	By MBRAUN Service
50	Over or under-pressure cooling compressor circulation	Cooling compressor for circulation defective	Compressor test Replace compressor	By MBRAUN Service
51	Fuse refrigerator has triggered	Compressor for refrigerator defective,	Replace compressor Compressor	MBRAUN Service / HVAC technician
52	Fuse box cooling has triggered	Compressor for box cooling defective	Replace compressor Check cabling	MBRAUN Service / HVAC technician
55	O2 too high automatic purge device is active	User note: oxygen value higher than alarm threshold	→ Purge box is activated automatically Eliminate leak	see chapt. 8.5.6
59	Spincoater suction valve not open	Suction valve spincoater defective Control pressure too low	Replace suction valve spincoater Set control pressure to 6 bar	
60	Spincoater: power supply fault	Power supply plug not plugged in Spincoater power supply defective	Plug in plug Replace spincoater power supply Active spincoater on touch panel	

Definition of the alarm and warning messages (PLC)

Nr.	Description	Possible causes of faults	Solutions	How to eliminate / see Chapter
96	Clean the H2O sensor!! See operating manual (ack. message)	Maintenance interval time H2O sensor exceeded	Clean H2O sensor according to MBraun service instructions Reset the run time H2O sensor	Chap. 12
97	Gas purifier: reactor 1 main valve input not closed	Main valve defective	Replace main valve	
98	Gas purifier: reactor 1 main valve output not closed	Main valve defective	Replace main valve	
99	Gas purifier: regeneration reactor 1 interrupted	Regeneration gas supply not sufficient Cancellation of regeneration by operator	Ensure regeneration gas supply Restart regeneration	see Chap. 11.5.1
100	Gas purifier: regeneration reactor 1 step-by-step operation	Operator notice		see chapt. 7
101	Gas purifier: check regeneration gas flow rate - ok?	Operator notice: Customer is asked to check the regeneration gas supply	Check regeneration gas supply	see chapt. 7
102	Gas purifier: reactor 2 main valve input not closed	Main valve defective	Replace main valve	
103	Gas purifier: reactor 2 main valve output not closed	Main valve defective Control pressure too low	Replace main valve Set control pressure to 6 bar	
104	Gas purifier: regeneration reactor 2 interrupted	Regeneration gas supply not sufficient Cancellation of regeneration by operator	Ensure regeneration gas supply Restart regeneration	see Chap. 11.5.1
105	Gas purifier: regeneration reactor 2 step-by-step operation	Operator notice		see chapt. 7

Nr.	Description	Possible causes of faults	Solutions	How to eliminate / see Chapter
106	Gas purifier: H2O alarm	H2O measurement exceeds the set alarm limits: Antechamber leaky, pipework leaky Batch brought in contains too much water vapour No cleaning effect of the reactor charging	Eliminate leak Adjust more pump refill cycles for antechamber automatic Regenerate reactor, use new reactor	See chapt. 9 See chapt. 7
107	Gas purifier: H2O sensor defective	H2O sensor defective H2O sensor unplugged	Replace H2O sensor Plug in H2O sensor	
108	Gas purifier: O2 alarm	O2 measurement exceeds the set alarm limits: Antechamber leaky, pipework leaky Batch brought in contains too much oxygen No cleaning effect of the reactor charging	Eliminate leak Adjust more pump refill cycles for antechamber automatic Regenerate reactor, use new reactor	See chapt. 9 See chapt. 7
109	Gas purifier: O2 sensor defective	O2 sensor defective O2 sensor unplugged	Replace O2 sensor Plug in O2 sensor	
110	Gas purifier: blower pressure sensor defective	Blower pressure sensor defective Blower pressure sensor unplugged	Replace blower pressure sensor Plug in blower pressure sensor	By MBRAUN Service
111	Gas purifier: blower pressure too low	Main blower circulation does not work: Blower unplugged Blower or frequency converter defective	Plug in blower Replace blower or frequency converter	By MBRAUN Service
112	Gas purifier: blower pressure too high	Hepa filter soiled	Replace Hepa filter	See chapt. 12
113	Gas purifier: fault regeneration gas sensor	Option: regeneration gas sensor Regeneration gas sensor defective	Replace regeneration gas sensor	

Definition of the alarm and warning messages (PLC)

Nr.	Description	Possible causes of faults	Solutions	How to eliminate / see Chapter
114	Gas purifier: regeneration gas pressure too low	Option: regeneration gas sensor Gas bottle empty Regeneration gas pressure set too low	Change gas bottle Set regeneration gas pressure (0.3 – 0.5 bar)	
115	Gas purifier: regeneration gas pressure too high	Option: regeneration gas sensor Gas supply pressure set too high	Set regeneration gas pressure (0.3 – 0.5 bar)	
140	Solvent filter: filter 1 main valve input not closed	Main valve solvent filter defective	Replace main valve solvent filter	By MBRAUN Service
141	Solvent filter: filter 1 main valve output not closed	Main valve solvent filter defective Control pressure too low	Replace main valve solvent filter Set control pressure to 6 bar	By MBRAUN Service
142	Solvent filter: check purge gas flow rate	Operator notice: Customer is asked to check the purge gas flow rate	Check purge gas flow rate, adjust higher than min. point and confirm the message	See chapt. 7
143	Solvent filter: filter 2 main valve input not closed	Main valve solvent filter defective Control pressure too low	Replace main valve solvent filter Set control pressure to 6 bar	By MBRAUN Service
144	Solvent filter: filter 2 main valve output not closed	Main valve solvent filter defective	Replace main valve solvent filter	By MBRAUN Service
145	LMF: alarm threshold solvent sensor is exceeded → Regenerate	Solvent indicator value exceeds set alarm threshold	With regenerative LMF: Regenerate reactor With non-regenerative LMF: Replace getter material	See chapt. 7
146	Solvent filter: regeneration filter 1 interrupted	Operator notice		See chapt. 7
147	Solvent filter: regeneration filter 2 interrupted	Operator notice		See chapt. 7

Nr.	Description	Possible causes of faults	Solutions	How to eliminate / see Chapter
160	Antechamber 1: pressure sensor fault	Atmospheric pressure sensor defective Atmospheric pressure sensor unplugged	Atmospheric pressure: replace sensor Atmospheric pressure: plug in sensor	By MBRAUN Service
161	Antechamber 1: vacuum sensor fault	Vacuum sensor defective Vacuum sensor unplugged	Replace vacuum sensor Plug in vacuum sensor	By MBRAUN Service
162	Antechamber 1: inner door not closed	Door switch not activated: Door switch defective Door not correctly closed	Replace door switch Close doors	
163	Antechamber 1: outer door not closed	Door switch not activated: Door switch defective Door not correctly closed	Replace door switch Close doors	
164	Antechamber 1: evacuation time exceeded	Antechamber leaky Vacuum tubing leaky Parts brought in gassing too much	Eliminate leak Increase maximum evacuation time	
165	Antechamber 1: vacuum valve not closed	Valve plug unplugged Vacuum valve antechamber defective	Plug in valve plug Replace vacuum valve antechamber	
167	Antechamber 1: antechamber is leaky (leak test)	Automatic leak test was not passed: Small leak antechamber Parts brought in gassing too much	Eliminate leak Increase max. leak rate	
175	Antechamber 2: pressure sensor fault	Atmospheric pressure sensor defective Atmospheric pressure sensor unplugged	Atmospheric pressure replace sensor Atmospheric pressure plug in sensor	
176	Antechamber 2: vacuum sensor fault	Vacuum sensor defective Vacuum sensor unplugged	Replace vacuum sensor Plug in vacuum sensor	

Definition of the alarm and warning messages (PLC)

Nr.	Description	Possible causes of faults	Solutions	How to eliminate / see Chapter
177	Antechamber 2: inner door not closed	Door switch not activated: Door switch defective Door not correctly closed	Replace door switch Close doors	
178	Antechamber 2: outer door not closed	Door switch not activated: Door switch defective Door not correctly closed	Replace door switch Close doors	
179	Antechamber 2: evacuation time exceeded	Antechamber leaky Vacuum tubing leaky Parts brought in gassing too much	Eliminate leak Increase maximum evacuation time	
180	Antechamber 2: vacuum valve not closed	Valve plug unplugged Vacuum valve antechamber defective	Plug in valve plug Replace vacuum valve antechamber	
182	Antechamber 2: antechamber is leaky (leak test)	Automatic leak test was not passed: Small leak antechamber Parts brought in gassing too much	Eliminate leak Increase max. leak rate	
203	Box pressure control valve VDA not open	Control valve defective Control pressure too low	Replace valve Set control pressure to 6 bar	
205	Box pressure control error -	Operator notice	Contact MBRAUN Service	By MBRAUN Service
206	Regeneration error -	Operator notice	Contact MBRAUN Service	By MBRAUN Service
207	Box valves box 1 not open	Box valves defective Control pressure too low	Replace box valve Set control pressure to 6 bar	By MBRAUN Service
208	Box valves box 2 not open	Box valves defective Control pressure too low	Replace box valve Set control pressure to 6 bar	By MBRAUN Service

Nr.	Description	Possible causes of faults	Solutions	How to eliminate / see Chapter
210	System not ready (no box preselected)	Both box valves closed: Box not switched on activated Box valves defective Control pressure too low	Activate one or more boxes Replace box valves Set control pressure to 6 bar	
212	Box pressure sensor defective	Box pressure sensor defective Box pressure sensor unplugged	Replace box pressure sensor Plug in box pressure sensor	
213	Box pressure is too low	Vacuum valve gas purifier does not close Vacuum valve antechamber does not close Refill valve antechamber is not closed	Replace defective valve	
214	Box pressure is too high	Pressure line in the box leaky or torn Purge gas flow rate too high with automatic purge	Eliminate leak in the gas supply Limiting of purge gas flow rate	
215	Box temperature is too high	Box cooling does not work: Box cooling unplugged Box cooling compressor defective	Plug in box cooling Check/replacement of compressor by MBraun Service	MBRAUN Service
216	Box cooling: fault temperature sensor	Temperature sensor defective Temperature sensor unplugged	Replace temperature sensor Plug in temperature sensor	

Definition of the alarm and warning messages (PLC)

Nr.	Description	Possible causes of faults	Solutions	How to eliminate / see Chapter
217	Temperature refrigerator is too high	Cooling does not work: Cooling has been deactivated Door is leaky Cooling compressor defective,	Increase temperature and wait for stabilisation of the temperature level Check for obstacles; Check O-rings Remove and/ or replace Replacement compressor by MBraun Service	MBRAUN Service / HVAC technician
218	Refrigerator: fault temperature sensor	Temperature sensor defective Temperature sensor unplugged	Replace temperature sensor Plug in temperature sensor	
220	Box pressure control error - box open or glove tear	Box open or glove tear	Check box pane and gloves for big leak, if necessary contact MBraun Service	MBRAUN Service
221	Pressure sensors Box1 and Box2: impermissibly high measurement value difference	Zero point drift box pressure sensors too high Gas stream circulation Box1-Box2 differs	Perform zero point comparison box pressure sensors HEPA filter Box1 - Box2 soiled to different degrees	MBRAUN Service
225	Box pressure sensor Box 2 defective	Box pressure sensor defective Box pressure sensor unplugged	Replace box pressure sensor Plug in box pressure sensor	MBRAUN Service
226	Box pressure Box 2 is too low	Vacuum valve gas purifier does not close Vacuum valve antechamber does not close Refill valve antechamber is not closed	Replace defective valve	MBRAUN Service
227	Box pressure Box 2 is too high	Pressure line in the box leaky or torn Purge gas flow rate too high with automatic purge	Eliminate leak in the gas supply Limiting of purge gas flow rate	

11.5 Recommissioning after cancellation and power failure

11.5.1 Normal flow regeneration

Step		Time	Action – STD
0	↓	Start 0 min.	Regeneration deactivated
1			Test regeneration gas ON
2			Test regeneration gas OFF
3	↓		Flow of regeneration in various steps
4 – [16]			
17	↓	MB200 after 960 Min. [MB300: after 1200 min.]	Regeneration ended

11.5.2 Regeneration of the gas purifier RKM

Case	Interruption in case of power failure	On return of power:
1	Cancellation in step 1 (regeneration gas check)	Unchanged -> jump to step 8 -> evacuation/refill cycles with shortened times (ges. 20 min)
2	Cancellation in steps 3 – 7	-> jump to step 8 -> evacuation/refill cycles with standard times, in order to guarantee cooling off of the reactor (regardless of the heating time already elapsed)
3	Power failure during step 3 or 4:	After return of power, the regeneration is continued at the beginning of step 3, that is, the complete heat-up phase of the regeneration process is run through again
4	Power failure during steps 5 ... 16:	After return of power, the regeneration is continued at exactly the point interrupted (no jump back to the beginning of the current step).

Error search: leak test

11.5.3 Regeneration of the gas purifier LMF

A cancellation of the regeneration programme is only possible in step 1 (without security question "Cancel yes/no"). There is a jump to the last step since no evacuation/refill cycles are necessary (RegGas = N2)

11.6 Error search: leak test

A leak test on the system is required

- On recommissioning
- With unexplained increase of the O2 content in the box
- Unexplained pressure increase/drop in the box

This procedure can be performed by **MBRAUN** Service.

Training leak test procedure

MBRAUN offers a training of the operating personnel for performing the leak test.
Please contact **MBRAUN** service.

12.1 Introduction	12-2
12.1.1 <i>Inspection and maintenance work</i>	12-3
12.1.1.1 Standard system.....	12-3
12.1.1.2 Optional components.....	12-3
12.1.1.3 Components of third-party manufacturers	12-3
12.1.2 <i>Maintenance contract with MBRAUN</i>	12-3
12.2 Safety during maintenance and inspection work	12-4
12.3 Overview of cyclical inspection and maintenance work	12-8
12.4 Preparation for inspection and maintenance work.....	12-10
12.4.1 <i>Basic work</i>	12-10
12.4.2 <i>Shutting down the system</i>	12-10
12.4.3 <i>De-energise system (for work on open system/on the electrical system)</i>	12-11
12.4.4 <i>Preparing opening of the box – fill box with ambient air</i>	12-12
12.5 Maintenance work.....	12-13
12.5.1 <i>Maintenance of inert gas box</i>	12-13
12.5.2 <i>Gloves</i>	12-14
12.5.2.1 Method 1: with interior sealing cover	12-16
12.5.2.2 Method 2: without interior sealing cover	12-19
12.5.3 <i>Replacing particle filter in the box</i>	12-21
12.5.4 <i>Calibrate/clean sensors</i>	12-22
12.5.4.1 Send oxygen sensor MB-OX-SE1 in for calibration.....	12-22
12.5.4.2 Cleaning MB-MO-SE-1 moisture sensor – while the system is in operation..	12-23
12.5.5 <i>Box cooling / refrigerator (optional)</i>	12-27
12.5.6 <i>Antechamber</i>	12-27
12.5.7 <i>Vacuum pump</i>	12-27
12.5.8 <i>Gas purification purifier</i>	12-27
12.5.9 <i>Solvent filter LMF (Option)</i>	12-28
12.5.10 <i>PLC controller</i>	12-30
12.6 Completing maintenance – recommissioning.....	12-30
12.7 Function tests	12-31
12.7.1 <i>Electrical test</i>	12-31
12.8 Disposal of replaced components	12-31
12.9 Return of components	12-31

Introduction

12 Inspection and maintenance

12.1 Introduction

In order to maintain a high safety standard for a closed inert gas system, regular inspection and maintenance of the complete system is required – including the integrated additional components of third-party manufacturers (cf. Chap. 6 Operating modes).

During the inspection and maintenance work, the closed circuit between external media connections, inert gas box and the gas purifier is interrupted.

This is associated with specific risks, which depend on the type and degree of hazard of the process materials used in the system. Please heed Chapter 4 Installation and the following section about "Safety".

Documenting inspection and maintenance

Carefully adhere to the inspection and maintenance intervals and document all work in the service and maintenance log.

Spare parts kit

In order to prevent production breakdowns, you should keep spare parts on hand for unplanned maintenance work so that they are constantly available (such as gloves, sensors, etc. see Chap. 14 Spare parts).

Who may do what?

	Qualified + trained personnel	Qualified electrical engineer	Qualified HVAC technician	Only MBRAUN Service
Intervention in the PLC controller				X
Electrical components		X		
Electrical-pneumatic components	X	X		
Cooling unit			X	
Maintenance work according to operating manual	X			
Repair and maintenance work not described in the operating manual				X

12.1.1 Inspection and maintenance work

12.1.1.1 Standard system

For standard systems, regular inspections must be performed of the main components gas purifier, box, antechamber and vacuum pump. *For an overview, see Chap. 12.3.*

Always perform after completing inspection and maintenance work:

- ▶ Function checks with - electrical test - leakage test

12.1.1.2 Optional components

MBRAUN inert gas systems can be equipped with optional additional components, for example:

- Universal measurement device
- Refrigerator, box cooling

Heed the maintenance and care instructions

See chapter for the optional components (7-9 A.. or 10 A..)

12.1.1.3 Components of third-party manufacturers

Some **MBRAUN inert** gas systems can be equipped with components from third-party manufacturers, for example:

- Vacuum pump(s)
- Compressor(s) for system cooling
- Compressor(s) for freezers

The original supplier documentation that describes the inspection and maintenance of these components is a component of the scope of delivery. *See Chap. 14 Supplier documentation*



WARNING

Risk of injury and damage!

- ▶ Heed all third-party technical documents during maintenance work.
-

12.1.2 Maintenance contract with MBRAUN

Optionally a maintenance contract can be signed with **MBRAUN**.

Please contact M. Braun service to discuss maintenance contract options.

Safety during maintenance and inspection work

12.2 Safety during maintenance and inspection work

Please note that the degree of hazard for inspection and maintenance work depends on the type of gases and process materials used.

The requirements and maintenance cycles named in this operating manual refer to minimum requirements for standard systems without the use of hazardous process materials.

Standard flow plan

MBRAUN recommends adapting the inspection and maintenance work to the specific conditions if necessary and integrating these into a specific standard flow plan for the process materials used and conditions on-site.

Adhering to maintenance cycles



DANGER

Risk of health and environmental damage due to material damage in case of non-adherence to maintenance cycles

The degree of hazard depends on the gases and process materials used.

- ▶ Adhere to the inspection and maintenance cycles
- ▶ Integrate the maintenance cycles into your operation-specific flow plan

If the inspection and maintenance cycles are not adhered to, all warranty and liability claims against **MBRAUN** are voided.

Qualification of personnel



WARNING

Risks to people and the environment due to improperly-performed inspection and maintenance work.

- ▶ Only qualified and trained personnel may perform inspection and maintenance work
- ▶ Follow the instructions in this operating manual
- ▶ Maintenance work that is not described in this operating manual may only be performed by **MBRAUN** service technicians or specially-trained personnel (HVAC technicians, electricians, qualified electro-pneumatic technicians -- see overview).

In case of improper inspection and maintenance cycles, all warranty and liability claims against **MBRAUN** are voided.

Risk of suffocation

DANGER

Risk of suffocation or health hazards when opening boxes under inert gas atmosphere!

- ▶ Do not breathe in inert gases!

Always ensure good ventilation of the room

When opening panes and doors, make sure:

- ▶ to adhere to the flow for preparation of maintenance work (*Chap. 12.4*)
 - ▶ The oxygen content in the box is more than 19.5 %
-

Electrical hazards

DANGER

Risk to people due to electrical shock in case of improper handling of electrical components!

- Only trained and qualified electricians may perform work on electrical components of the system!

Before starting work on the control cabinet and/or electrical components:

- ▶ Switch off the system with the main switch
 - ▶ Remove the system from the mains
 - ▶ Secure the system against undesired switching on
-

Exceptions:

Particular maintenance work and functional tests can be performed when the power supply is switched on (replacement of sensors, filters, gloves) as long as no hazardous processes/process materials are used.

Heed the notes in this operating manual.

Safety during maintenance and inspection work

Hazard due to process materials and gases



DANGER

Health and environmental risks due to gases, processes and process materials used!

Gases, processes and process materials used can, in contact with oxygen, be easily flammable, explosive, toxic or present a risk to health and the environment. They can react with one another and form unintended and unknown substances.

Before beginning maintenance work in the box

- ▶ Mark all containers and supply lines that contain hazardous process materials
- ▶ Remove all hazardous process materials (in closed containers) from the box
- ▶ Handle all components that come into contact with process materials carefully (filter material for solvent filters, particle filters, sensors, etc.)
- ▶ Depending on the requirements, wear personal protective equipment (e.g. complete

safety mask, protective gloves, safety goggles)



- ▶ Dispose of all contaminated components of the system properly according to the locally-applicable regulations.

Removal of particle filters and sensors when the system is switched off



DANGER

Personal injury and environmental damage due to contamination through hazardous processes/process materials!

Sensors and particle filters are constantly subjected to the gas flow in the box/the gas purifier. When using hazardous materials in the inert gas box, people and the environment are at risk!

Before removing sensors and particle filters:

- ▶ Purge box / pipework
- ▶ Switch off system!
- ▶ Clean box
- ▶ Follow the description in Chapter 12.4 Preparing maintenance and inspection work

Depending on the application and degree of hazard of the processes/process materials, constructive and functional additional equipment may be necessary.

Contact **MBRAUN** Service.



Only use for standard systems with non-hazardous processes and process materials:

Maintenance work during operation of the system

For maintenance work during operation of the system – as for replacement of gloves, sensors or particle filters – ambient air can penetrate the system through the open flange. Box atmosphere can get into the ambient air.

NOTICE

During dismounting of the sensors, the contamination of the box atmosphere with ambient air must be avoided!

- ▶ Always work quickly and without interruption
 - ▶ Follow the description in the operating manual
-

Overview of cyclical inspection and maintenance work

12.3 Overview of cyclical inspection and maintenance work

The specifications of the intervals are minimum specifications. Depending on the processes/process materials used, shorter intervals may be necessary.

*) Only by **MBRAUN** Service

***) Only trained HVAC technicians

**) Only trained electricians

		Monthly	Quarterly	Semi-annually	Annually	Other	See chap.
Inertgas box							
	Clean sensor (H2O sensor)		x				
	Calibrate sensors (O2 sensor)				x	see 12.5.1.2	MBRAUN Service
	Check to make sure that all connections are tight and free of contamination and damage		x				
	Check omega seals of the box windows		x				
	Check magnetic valves		x				
	Perform complete leak test		x				
	Perform function test		x				
	Check lighting				x		
	Check and if necessary replace magnetic valves				x		
	Check general state of gloves and check for tears.		x				
	Replace gloves				x	Or as needed	
	Replace particle filters				x		

		Monthly	Quarterly	Semi-annually	Annually	Other	See chap.
Antechamber							
	Check to make sure that all connections are tight and free of contamination and damage	x					
	Check antechamber seals for damage	x					
	Replace sealing rings					if necessary	
	Optional: safety valve test 0.1 bar / 0.3 bar	x					
Vacuum Pump							
	Connection of the vacuum pump: sealing rings						
	Check functionality of the valves						
Gas purifier							
	Check to make sure that all connections are tight and free of contamination and damage		x				
	Check magnetic valves		x				
	Test blower		x				
	Test vacuum pump		x				
	Perform function test		x				
	Test blower, replace if necessary		x				
	Test purification unit		x				
	Replace purifier filling					if necessary	*)
	Check and if necessary replace valve seals		x				
	Test cooling system						**)
	Check coolant						**)
LMF							
	Replace filter medium (active carbon)	x			x		12.6.9

! Note also the details about maintenance in the chapter for the additional components (*Chap. 7-9 A..X*) as well as the additional equipment (*Chap. 10 A..X*).

Preparation for inspection and maintenance work

12.4 Preparation for inspection and maintenance work

12.4.1 Basic work

-
- 1 ▶ Preparations:
 - Provide all required spare parts (gloves, particle filters, sensors, etc.)
 - Provide personal protective equipment, insofar as required
 - Provide cleaning materials (cleaning agents, cloths, waste containers)
 - Provide containers for the proper disposal of replaced components
 - 2 Ensure good ventilation of the room
 - 3 ▶ Unload sensitive/hazardous process materials (in closed containers).
 **WARNING** Depending on the type and degree of hazard of the process materials used: if necessary, heed all safety-relevant requirements of your process-specific standard flow plan
-

12.4.2 Shutting down the system

-
- 1 ▶ Deactivate all processes: - of the integrated additional components - of the system (no antechamber processes active, no regeneration active)
 - 2 ▶ Switch off circulation
 - 3 ▶ Switch off sensors for O₂ and H₂O
 - 4 ▶ Close external gas feed
-

12.4.3 De-energise system (for work on open system/on the electrical system)

- 1 ▶ Switch off the main switch

- 2 ▶ If necessary, disconnect the system from the mains

- 3 ▶ Secure system against unintentional switching on

- 4 ▶  **DANGER** Ensure through measurement that the system is de-energised

- 5 ▶ Begin work on the control cabinet / on the electrical system

See also: maintenance work + functional tests that require power supply

Preparation for inspection and maintenance work

12.4.4 Preparing opening of the box – fill box with ambient air

Prerequisite

- > Heed the safety chapter 3
- > Heed the safety instructions in this chapter for maintenance and inspection work.
- > The set-up conditions (ventilation of the room!) are adhered to (see Chap. 4.3.1)
- > Preparatory work has been performed (Chap. 12.4.1- 12.4.2)
- > For electrical work inside the box: Chap. 12.4.3

 **WARNING** Before beginning maintenance work in the box/before opening the box (inner antechamber door, window, gloves), the box must be filled with ambient air up to an oxygen content of at least 19.5 %.

a) **Standard boxes / antechambers with a total volume up to 6 m³ (only with use of non-hazardous gases (N₂) and process materials):**

Let box/antechamber atmosphere (with good room ventilation!) escape slowly:

1. First open outer antechamber door and let atmosphere escape slowly
 2. Open inner antechamber door
 3. Wait appropriately depending on the box volume.
 4. Ensure sufficient ventilation of the room
 5. The box windows/doors can be opened
-

b) **Special systems: with use of large-volume boxes, hazardous gases and process materials:**

 **DANGER** The replacement of the box/antechamber atmosphere may only be done with a connected exhaust air system!

Optional: The feed of ambient air should be done using an **MBRAUN** air purge unit

Before opening box windows/doors:

- ▶ Measure the oxygen content within the box using the test flange;
 - ▶ If O₂ content is greater than 19.5%: the box windows/doors can be opened
 - ▶ Perform maintenance work
-

12.5 Maintenance work

Prerequisites:

- > Preparatory work has been performed (*See above, section 12.4*)

12.5.1 Maintenance of inert gas box

Remedy for error messages (see Chap. 11):

- Pressure line in the box leaky or torn: eliminate leak
- Defective vacuum valve gas purifier/antechamber: replace vacuum valve
- Defective refill valve antechamber: replace refill valve
- Defective box valve: replace box valve
- Pressure indicator error: plug in/replace box pressure sensor

Cleaning the box window

Clean with customary cleansers (no aggressive or caustic cleansers).

Use a soft, lint-free cloth or vacuum cleaner with soft cleaning brush.

System with integrated MBRAUN vacuum cleaner system:

The vacuum cleaner system can be used with a brush attachment for cleaning the inside of the window.

Maintenance work

12.5.2 Gloves

Basic rules

- Heed the basic rules for inspection in the inert gas box chapter while using the gloves.
- Always keep a set of gloves, O-rings and glove sealing cover ready for an unplanned change (see Chap. 14 Spare parts)
- All gloveport feedthroughs may never be sealed at the same time!
- Recommendation: Train the glove change regularly so that in case of error during ongoing operation you can replace the gloves quickly and safely
- With the use of sensitive processes or those that endanger health or the environment: additional equipment for redundant safety is required! (see Chap. 4. Installation) Specify the procedure in your operation-specific standard flow plan.
- Keep the appropriate personal protective equipment (PPE) on hand.



WARNING

Ambient air penetrates the box due to damaged gloves and disturbs the inert gas atmosphere. The box atmosphere can escape and cause personal injuries.

Depending on the gases and processes/process materials used, there can be material damage and/or personal injury (risk of suffocation!).

Never repair and reuse damaged gloves!

- ▶ Damaged gloves must always be replaced with new ones!
- ▶ Replace worn and defective gloves immediately!

Regular care

Only outside of the gloves (user's side):

- ▶ Sprinkle with a little talcum powder

NOTICE

Do not use any talcum powder:

- Box-side, on the inside of the gloves
 - In cleanrooms!
-

Replace gloves

The process differs depending on the type of processes/process materials used. **MBRAUN** recommends the following application types:

Application glove change	In ongoing operation	With box out of service / Box is under ambient air	Glove change with sealing cover	Glove change without sealing cover
Standard (non-sensitive, non-hazardous processes/process materials)	x			x
Standard (sensitive materials)	(X)	x	(X)	x
Replacement of several gloves for large-volume (MOD) boxes		x		x

 **DANGER** With the use of processes/process materials that present a hazard to health or the environment:

There are special instructions for gloves and gloveport feedthroughs with deviating methods of changing *gloves* (see special chapter 8 A.. / 10 A.. "Oval gloveport feedthroughs").

Preparation (Material + Box)

Preparing material:

- Glove sealing cover
- Make sure that the right gloves are used.
- With anatomical gloves, mark the right and left glove
- If necessary wear personal protective equipment



 **MBRAUN** recommends keeping on hand a parts kit with the most important measurement devices and spare parts: for example, measurement devices such as leak testers, spare gloves, outer sealing covers, etc.

Maintenance work

1. Preparation of the box:

A Regular change with the box out of operation (with the use of gases, processes/process materials hazardous to health or the environment)

Take box out of operation:

- End processes
- Purge box
- Switch system OFF
- Close gas connections
- Fill box with ambient air

B Regular change in ongoing operation

(only with use of process/process materials that do not endanger health and the environment)

- ▶ Prepare the glove change carefully
- ▶ Work quickly and without interruption
- ▶ Load glove sealing cover into the box
- ▶ Unload sensitive materials or keep in the antechamber in the box during the glove change
- ▶ Ensure good ventilation of the room

Preparing status box:

- ▶ Put box in slight over pressure (approx. 1 - 2 mbar)

12.5.2.1 Method 1: with interior sealing cover

NOTICE

Undesired pressure increase in the box!

- ▶ For glove change in ongoing operation: All gloveport feedthroughs may never be sealed at the same time!
-



Attach inner sealing cover either through the gloveport feedthrough whose gloves should be replaced (knob is then outside) or through another gloveport feedthrough (knob is then inside).



Gloveport feedthrough is sealed.



Remove both O-rings from the gloveport feedthrough

Remove glove



Roll new glove on firmly so that as little air as possible remains in the new glove.

Maintenance work



NOTE: Place anatomical gloves in the correct position.

Place new, rolled-on glove in the (sealed) gloveport feedthrough.



Put new glove onto the gloveport feedthrough up to the inner notch.

Align glove correctly on the gloveport feedthrough



Secure glove onto the outer two notches of the gloveport feedthrough with two new O-rings.

Remove inner sealing cover.

Putting the box back into operation:

After the glove change:

- ▶ Purge inert gas box. See *Chapter 8.5 Inertising the box*.
- ▶ As soon as the oxygen and moisture content is less than 100 ppm, the box may be put back into circulation operation.

! To dispose of used gloves: *follow Chap. 12.8*

12.5.2.2 Method 2: without interior sealing cover

- Put inert gas box in slight over pressure (approx. 1 - 2 mbar)



Push new glove into the old glove.

NOTE: Make sure that both gloves lie precisely in one another so that there is as little air as possible between the gloves.



Remove both O-rings from the gloveport feedthrough.



Pull old glove off the gloveport feedthrough and **IMMEDIATELY** put new glove over it.

Pull glove on the gloveport feedthrough up to the inner notch and align correctly.



Only secure new glove first with a new O-ring on the inner notch of the gloveport feedthrough.

Maintenance work



Pull off old glove from inside



Then secure new glove with a second new O-ring on the outer notch of the gloveport feedthrough.

Unload old glove.

Putting the box back into operation:

After the glove change, remove unwanted oxygen and moisture remains:

- ▶ Purge inert gas box (manually) See Chapter 8.5 *Inertising the box*

! To dispose of used gloves: *follow Chap. 12.8*

12.5.3 Replacing particle filter in the box

NOTICE

With saturated box filter, there can be contamination/disturbance of the box atmosphere and of the process materials as well as an increase in box pressure!

- ▶ Replace saturated filters in timely fashion
- ▶ Used filters may not be reused!

 **DANGER** with use of hazardous process materials in the box:

Preparation

- > Prepare new filter
- > Place filter in a closed container



In ongoing operation:
 Carefully pull out used filter unit
 Place in a container that can be sealed
 Unload and dispose of properly.
 Carefully clean box of loose particles



Load new filter
 Put on new filter and screw in

Maintenance work

12.5.4 Calibrate/clean sensors

**WARNING**

The sensor is constantly subjected to the gas flow. With the use of hazardous materials in the inert gas box, there is the risk of a contamination.

The exchange process described here is not suitable for the use of hazardous materials.

- ▶ Contact **MBRAUN** for additional functions/equipment

For the removal of used sensors:

- ▶ If necessary wear personal protective equipment (PPE)
- ▶ Place the sensor in a container that can be sealed immediately after removal
- ▶ Dispose of used sensors according to all applicable local and national safety guidelines for the handling of potentially-contaminated material

Send used sensors to **MBRAUN**:

- ▶ Use the decontamination declaration
 - ▶ Be sure to follow the instructions (see attachment to this chapter)
-

12.5.4.1 Send oxygen sensor MB-OX-SE1 in for calibration

The oxygen sensor MB-OX-SE1 is maintenance-free. **MBRAUN** recommends (at least) an annual calibration of the oxygen sensor. The calibration cycles depend on the use of the measurement devices and the gases used (purity, trace gases, etc.).

Removing the O₂ sensor (standard systems – only with use of non-hazardous materials)



Only with use of non-hazardous materials: replace during operation of the system

Preparations

- > Provide a new oxygen sensor MB-OX-SE1
- > If necessary wear personal protective equipment

Status system

- ▶ Switch off O₂ sensor on the touch panel
- ▶ Bring box pressure to a value between +1.0 and +5.0 mbar
- ▶ Switch off circulation operation

Replacing the oxygen sensor



CAUTION **WORK QUICKLY AND WITHOUT INTERRUPTION!**

- ▶ Open the securing clamp
- ▶ Remove the used O₂ sensor
- ▶ Insert the new O₂ sensor



After an exposure to the ambient air, it can take several hours until the sensor provides accurate measurement values about inert gas conditions again.

- ▶ Reset box pressure to normal pressure
- ▶ Switch on circulation operation
- ▶ Activate sensor on the touch panel
- ▶ Contact **MBRAUN** Service for calibration.

12.5.4.2 Cleaning MB-MO-SE-1 moisture sensor – while the system is in operation

NOTICE

Insufficient maintenance of the moisture sensor causes imprecise measurements and compromises the cleanliness of the box atmosphere, after 2000 hours of operation a cleaning of the sensor is necessary!

- ▶ Clean the moisture sensor at the latest when asked to do so by the pop-up menu on the touch panel (See chapters *inert gas box*, *sensor monitoring of the inert gas atmosphere*).

Cleaning the sensor



WARNING

Personal injuries due to chemical burns to the skin and the eyes with use of phosphoric acid as cleanser!

- ▶ Wear protective gloves and goggles!



- ▶ In case of contact with phosphoric acid, rinse skin immediately with running water.
- ▶ If phosphoric acid gets in the eyes: Rinse eyes immediately with running water.
- ▶ Contact a physician immediately.

Maintenance work

Preparation:

- > soft, absorbent, lint-free cloth (cotton) / absorbent household paper
- > distilled water
- > small quantity of 85% phosphoric acid (H₃PO₄) .
- > blind cover for sealing the circulation pipework (DN40)
- > protective clothing, incl. protective gloves and goggles



1



2

Unplugging the sensor cable

- 1 Moisture sensor with cable
- 2 Unplug connector



3



4

Dismounting the sensor

- 3 Loosen clamp
- 4 Remove sensor



5



6

Sealing pipework with blind flange

- 5 Put on blind cover
- 6 Attach flange clamp



7



8

Removing the protective cap

7 Unscrew carefully

8 Carefully remove the protective cap



Distilled water



9 + 10

Cleaning the sensor

9 Moisten sensor with distilled water

10 Carefully clean and dry sensor with the cloth



85% phosphoric acid H₃PO₄



11

Moistening the sensor

11 Moisten sensor completely with a thin coating of phosphoric acid.



Screw on the protective cap

12 Screw the protective cap back on

Maintenance work

Install the moisture sensor

The installation of the moisture sensor takes place in reverse order (see above, steps 1-6):

- ▶ Remove clamp and blind cover
- ▶ Insert sensor
- ▶ Fasten sensor with the clamp
- ▶ Plug in sensor plug

Operating hours reset moisture sensor

After cleaning the sensor, reset the operating hours:

- ▶ Call up [Maintenance of H2O sensor](#) from the [General Parameters](#) screen.

Service O2 sensor

01705

← "Operating hours" field

- ▶ Touch the Reset button

-
- ! After fresh moistening and an exposure to the ambient air, it can take two to six hours until the moisture sensor provides accurate measurement values about inert gas conditions again.
-

12.5.5 Box cooling / refrigerator (optional)

! Maintenance may only be performed by a trained HVAC technician!

12.5.6 Antechamber

▶ Check regularly:
▪ Sealing rings for soiling/damage/material fatigue
▪ Locking mechanism for easy running
▪ Connection of the vacuum pump: sealing rings
▪ Functionality of the valves

- ▶ Grease sticky antechamber doors slightly with vacuum grease
- ▶ Replace sealing rings

! Some areas must remain free of lubricants.

- Never use lubricants inside the box!

12.5.7 Vacuum pump

See supplier documentation

12.5.8 Gas purification purifier

Maintenance work on gas purification purifiers may only be performed by **MBRAUN** Service, especially

- Replacement of the purifier filling
- Replacement of the heater
- Replacement of the inlet/outlet valves

Maintenance work

12.5.9 Solvent filter LMF (Option)

Prerequisites:

! Heed the safety chapter 3 and the foregoing safety instructions in Chap. 12.2

Replacing the filter medium

MBRAUN recommends the replacement of the filter medium every 3-6 months. With frequent use of solvents, an earlier replacement may be necessary.



WARNING

Risk of personal injury and material and environmental damage due to remaining solvents/vapours during changing of the filter medium!

- ▶ Handle the replacement of the used filter medium with the greatest care
- ▶ Wear personal protective equipment (PPE): appropriate breathing protection full mask (with suitable filter), protective gloves and eye protection, clothing protection



- ▶ Inform your fire safety officer before changing the filter medium
 - ▶ Keep suitable extinguishing agents on hand
-



Active carbon LMF (absorption principle): Reliable operation of the solvent filter is only guaranteed with active carbon from **MBRAUN** (item no. 2182000).

Preparation:

Provide **MBRAUN** active carbon

Provide solvent-resistant container that can be sealed

Wear personal protective equipment

Changing the LMF filter medium:

1. Set valves: put solvent filter in bypass function

Setting the valves:

See valve scheme Gas purifier chapter 7.4.3

- ▶ Open valve 3

- ▶ Close valve 1
- ▶ Close valve 2
- ▶ Put valve 4 in "closed" position.

2. Replace filter medium

- ▶ Open flange for emptying on the solvent filter (OUT) and catch the used filter medium in a container. Then close the flange.
- ▶ Open the flange for filling (IN) and fill with 5 kg active carbon. Then close the flange.

3. Evacuate and refill the solvent filter

- ! ▶ Put valve 4 in the EVACUATE position and
 - ▶ leave in this position for 12+ hours
-
- ▶ After refilling, put the valve in the REFILL (REFILL) position until the manometer has reached the value "0"..
 - ▶ Put valve 4 in the CLOSED (CLOSED) position. The solvent filter can be put back into circulation operation (see chap. Gas purifier solvent filter (LMF)).

Completing maintenance – recommissioning

12.5.10 PLC controller

- ▶ Replace buffer battery (CR2032)
- ▶ Check tight fit of all clamps
- ▶ In case of error, it may be necessary to replace the controller: please contact **MBRAUN** Service.

12.6 Completing maintenance – recommissioning

Follow-up:	
1	Establish current connection
2	Switch system on
3	Function checks - with power supply: - Valves - Sensors
4	Perform leak test on the system

12.7 Function tests

12.7.1 Electrical test

After each change to the electrical systems / maintenance and repair, perform an electrical test.



Cyclical testing is due according to BGV A3 or in-house regulation.

- ▶ Document the test performed in your maintenance log.

12.8 Disposal of replaced components

- ! All replaced components must be disposed of properly according to local regulations without endangering health or the environment.

Solvent filter (active carbon)

The filter material of solvent filters (active carbon) can be contaminated by process chemicals and solvents.

- ▶ Heed the requirements from the safety data sheets (material data sheets) of the process materials used.
- ▶ Dispose of the filter material according to the locally-applicable national guidelines.

12.9 Return of components

Before parts can be sent to **MBRAUN**:

- ▶ Fill out the included "Decontamination declaration" form:
- ▶ First send the decontamination declaration to **MBRAUN**
- ▶ Await confirmation: **MBRAUN** Service will inform you whether the parts can be accepted
- ▶ **Only send parts after receiving confirmation**

- ! **MBRAUN** does not accept parts if
 - Parts are sent without filled-out "Decontamination declaration" form and there is no initial confirmation from Service
 - Contaminated parts are those that were in contact with substances that pose risks to health and the environment

Declaration about Decontamination

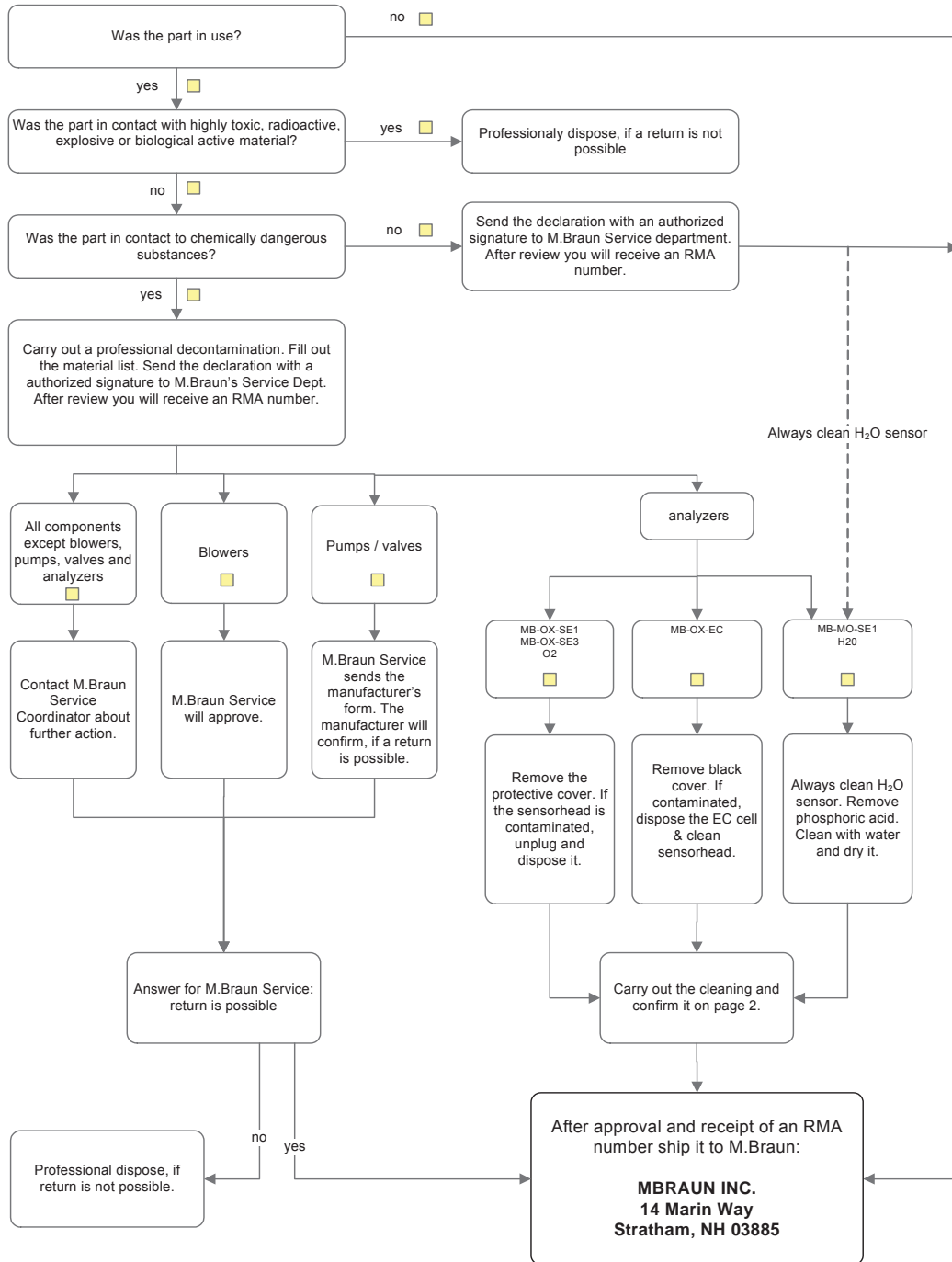

Legally binding declaration:

We hereby assure that the information in this statement is complete & accurate. The transportation of the contaminated products must be carried out in accordance with legal requirements. We realize that we are liable to the MBraun Inc. for damages caused by incomplete and incorrect information.

Name of the authorized person (Please print)	Date	Signature	Company stamp



Declaration about Decontamination

The service and repair of M.Braun glove boxes and their components can only be performed after presentation of this completed form. The completed declaration must have been checked by M.Braun Service before a part can be accepted. After review and approval of the declaration you will receive a return material authorization number (RMA number).
 Note: The shipment of contaminated parts may be a violation of national and international laws.

1. Project number / year of manufacturing	6. Company / institute
2. Type of component: blower, analyzer, ...	7. Address
3. Type / name / serial number	
4. Special equipment installed (e.g. LMIF)	
5. Reasons for return	

List of hazardous materials and certification of decontamination

Enter all hazardous materials which the component was in contact with. Please print:

Pos.	CAS-Nr.	Name of chemical	Chemical formula	Class of risk
1				
2				
3				
4				
5				
6				

Hereby we assure that the component has been cleaned and it is not contaminated.

Signature

Date

- 13.1 Gasreinigung / Gas Purifier / Purificateur de gaz** Error! Bookmark not defined.
- 13.1.1 Standard: Vorderansicht / Front View / Vue de face .. **Error! Bookmark not defined.**
 - 13.1.2 Rückansicht / Rear side / Vue arrière..... **Error! Bookmark not defined.**
 - 13.1.3 Option: Boxspülen / Box Purging / Purge de la boîte . **Error! Bookmark not defined.**
 - 13.1.4 Option: Lösungsmittelfilter / Solvent filter / Filtre à solvants **Error! Bookmark not defined.**
- 13.2 Inertgas-Box / Inertgas Box / Boîte à gants.** Error! Bookmark not defined.
- 13.2.1 Gehäuse und Beleuchtung / Chassis and light / Châssis et éclairage **Error! Bookmark not defined.**
 - 13.2.2 Partikelfilter / Particle Filter / Filtre à particules **Error! Bookmark not defined.**
 - 13.2.3 Handschuhe + Zubehör / Gloves and Accessoires / Gants et accessoires **Error! Bookmark not defined.**
 - 13.2.4 Messgeräte / Sensors / Capteurs de mesure **Error! Bookmark not defined.**
- 13.3 Schleuse / Antechamber / Sas** Error! Bookmark not defined.
- 13.3.1 Hauptschleuse / Main Antechamber / Sas principal 390 mm **Error! Bookmark not defined.**
 - 13.3.2 Minischleuse / Mini Antechamber / Mini Sas 150 mm **Error! Bookmark not defined.**
- 13.4 Vakuumpumpe / Vacuum Pump / Pompe à vide** Error! Bookmark not defined.
- 13.4.1 Standard..... **Error! Bookmark not defined.**
 - 13.4.2 Upgrade: Tri-Scroll-Vakuumpumpe / Vacuum pump / Pompe à vide **Error! Bookmark not defined.**
- 13.5 Steuerung / Controlling / Commande** Error! Bookmark not defined.
- 13.5.1 Bedienpanel / Operation Panel / Écran tactile..... **Error! Bookmark not defined.**
 - 13.5.2 Fußschalter / Foot Switch / Pédalier..... **Error! Bookmark not defined.**
- 13.6 Option : Kühlschrank / Refrigerator / Congélateur** Error! Bookmark not defined.

13 Ersatzteile / Spare Parts / Pièces détachées



Workstation
UNIlab Pro SP/DP



Workstation
UNIlab Plus SP/DP

! **MBRAUN** empfiehlt, einen Ersatzteil-Koffer mit den wichtigsten Ersatzteilen bereit zu halten: beispielsweise Ersatzhandschuhe, Außenverschlussdeckel, O₂- und H₂O-Sensoren.

MBRAUN recommends to held a spare part case with the main spare parts in stock, such as gloves, antechamber door, O₂ and H₂O-analyzer etc.

MBRAUN recommande d'avoir un lot de pièces détachées en stock, comme des gants, porte de sas, Sondes O₂ et H₂O

Übersicht / Overview / Vue d'ensemble



Pos	Beschreibung/ Description /Description	Siehe Kap /.See chapter /Voir chapitre
1	Gasreinigung / Gas Purifier / Purificateur De gaz	13.1
2	Inertgas-Box / Inertgas box / Boîte à gants	13.2
3	Schleuse / Antechamber / Sas	13.3
	<ul style="list-style-type: none"> ▪ Hauptschleuse / Main antechamber / Sas rond - 390 mm ▪ Mini-Schleuse / Mini antechamber / Mini sas - 150 mm 	
4	Vakuum-Pumpe / Vacuum pump / Pompe à vide (option)	13.4
5	Steuerungselemente / Controlling elements / Éléments de commande	13.5
	a) Bedienpanel / Touchpanel / Écran tactile	
	b) Fußschalter / Foot switch / Pédalier	
6	Zusatzkomponente (option): Kühlschrank Additional components (option) Refrigerator Composants Supplémentaires (option) : Congélateur	13.6

Gasreinigung / Gas Purifier / Purificateur de gaz

13.1 Gasreinigung / Gas Purifier / Purificateur de gaz

13.1.1 Standard: Vorderansicht / Front View / Vue de face

Vorderansicht / Front View / Vue de face



Nr.	Beschreibung Description Description	Merkmal Feature Caractéristique	Artikel-Nr. Item no. Article-no
1	Schaltschrank Electrical Cabinet Armoire électrique	(elektrische Komponenten siehe Schaltbild, Kap. 13) (electrical components see Wiring Diagram) (composant d'électrique voir Schéma de câblage)	
2	Hauptschalter Main switch Interrupteur principal	2polig, 16A,600V	2602675
3	Durchflussmesser komplett / Flowmeter complete Débitmètre complet	4..25 NI	2600027

13.1.2 Rückansicht / Rear side / Vue arrière

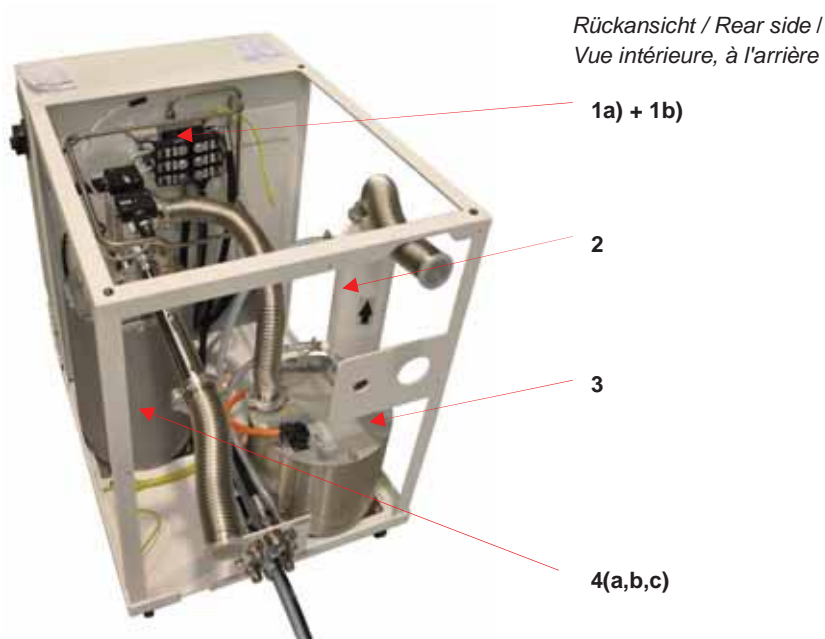

Nr.	Beschreibung Description Description	Merkmal Feature Caractéristique	Artikel-Nr. Item no. Article-no
1 a	Ventil-Set Valve set Kit de vannes	(Spule, Kern, Feder) (Core, spool, spring) (bobine, noyau, ressort)	2600793
1 b	Ventil-Block Valve Block- Distributeur	6-fach / 6 valves / 6 voies	4600978 *)
		10-fach / 10 valves / 10 voies	4600979 **)
2	Kühler Heat Exchanger Echangeur thermique	komplett / complete / complet	7016893 ***)
3	Gebläse Blower Turbine	MB-BL-01	9002832
4 a	Reaktor Gasreinigung, komplett Reactor Gas purification, complete Réacteur de purification de gaz, complet	H ₂ O / O ₂ , 230 V	9002043-KF
		H ₂ O / O ₂ , 115 V	9002044-KF
4 b	Kupferkatalysator Cu-Catalyst Catalyseur cuivre	4.5kg	2600839
4 c	Molekularsieb Molecular sieve Tamis moléculaire	5.5 kg	3240262

*) SP Version **) DP Version ***) option

Gasreinigung / Gas Purifier / Purificateur de gaz

Forts. Rückansicht / Rear side /
 Vue intérieure, à l'arrière

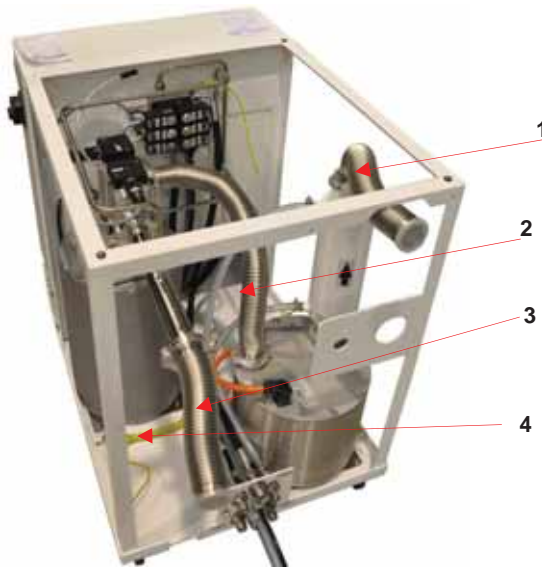

Nr.	Beschreibung Description Description	Merkmal Feature Caratéristique	Artikel-Nr. Item no. Article-no
1	Wellschlauch Flexline Tuyau annelé	DN40KFx350	3203000
2	"	DN40KFx500	3200072
3	"	DN40KFx250	3240545
4	Haupterdungsanschluss Main grounding connection Raccord de terre principal	10mm ² / 5meter	2603712
--	Erdungssatz für Groundig-Set for Kit de mise à la terre pour	UNILAB	2603711
--	"	Labmaster	2603710

13.1.3 Option: Boxspülen / Box Purging / Purge de la boite

Rückansicht / Rear side

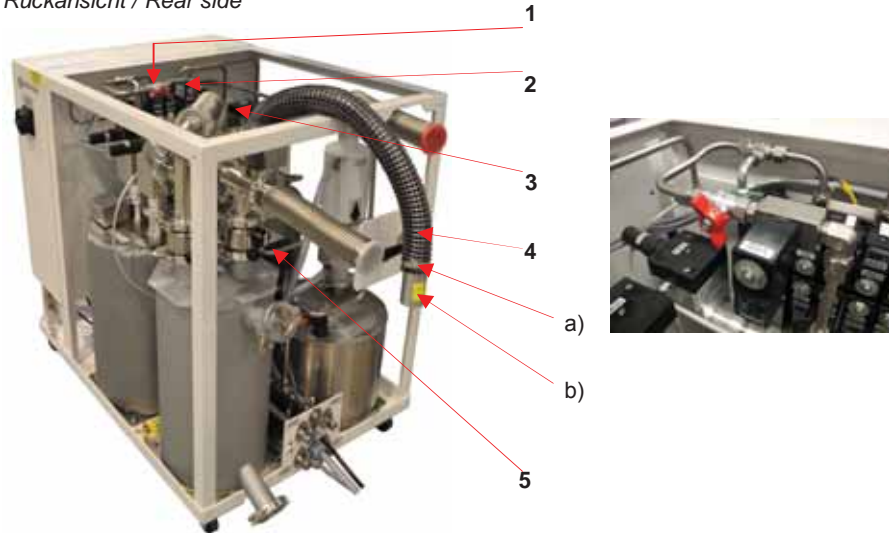

Pos	Beschreibung Description Description	Merkmal Feature Caractéristique	Artikel-Nr. Item no. Article-no
1	Kugelhahn 2-Wege 2-way ball valve Robinet à boisseau	3/8" V2A	3240521
	"	3/8" MS	5017016
2	Magnetventil Magnetic Valve Set Électrovanne	VSE	4600977
3	Eckventil HV Angle Valve Vanne à angle droit	MB-EPV-40 (Al)	9002531-K
	"	vernickelt, NI-plated, nickelée	9002533-K
4	PVC-Schlauch (Spülen Ausgang) PVC-Hose (Purging Outlet) Tuyau en PVC (sortie de purge)	800mm	2602195
a)	Schlauchklemme Hose clamp Collier pour tuyaux souples	32-50mm	2501116
b)	Al-Rohr 42x1 L=100mm Al-Tube Tube en Alu	42x1 L=100mm	2300221
5	Rückschlagventil komplett (Ausgangventil) Non-return valve (Purging out) Clapet anti-retour (vanne de sortie)	DN40 komplett	7024588

13.1.4 Option: Lösungsmittelfilter / Solvent filter / Filtre à solvants

Rückansicht / Rear side

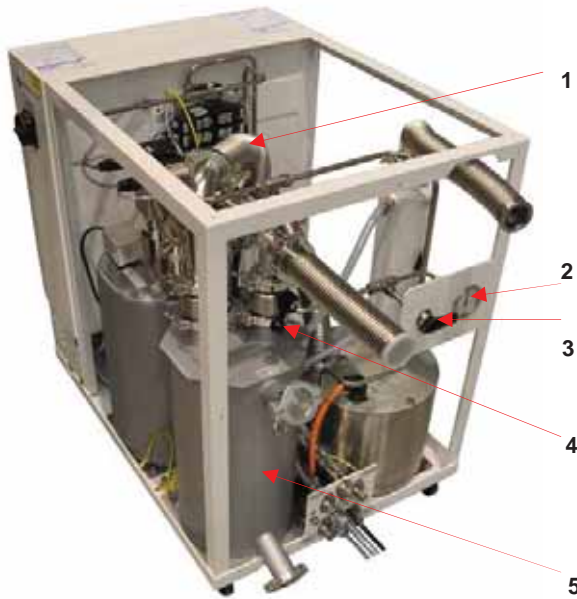

Pos	Beschreibung Description Description	Merkmal Feature Caractéristique	Artikel-Nr. Item no. Article-no
1	Wellschlauch Flexline Tuyau annelé	DN40KFx500	3200072
2	Manometer Manomètre	-1/+0,6bar -100/60kPa	3000072
3	3-Wege-Ventil 3-Way Ball Valve Vanne 3 voies	10mm MS 10mm BS 10mm MS	2200480
4	Handventil Manual valve Vanne manuelle	DN40KF VA DN40KF SS DN40KF VA	9004501
5	Lösungsmittelfilter Solvent Filter Colonne Filtre à solvants	LMF	9007091
--	Aktivkohle Activated Carbon Charbon actif	5.5kg	2182000

13.1.4.1 Option: Regenerierbarer LMF / Regenerable solvent filter / Filtre à solvants régénérable



Rückansicht / Rear side



Pos	Beschreibung Description Description	Merkmal Feature Caractéristique	Artikel-Nr. Item no. Article-no
1	Druckregler Pressure controller Régulateur de pression	1/8"	4601276
2	Durchflussmesser komplett Flowmeter complete Débitmètre complet	mit Rückschlagventil with non- return-valve avec clapet anti-retour	2600027
--	Reaktor regenerierbar Reactor regenerable Réacteur régénérable	H2O/ O2 - 230V 13A für / for / pour reg. LMF	7038320
--	Molekularsieb Molecular sieve Tamis moléculaire	13x 1/8 APG	3240262

13.1.5 Option: ECO Mode / Eco Mode /

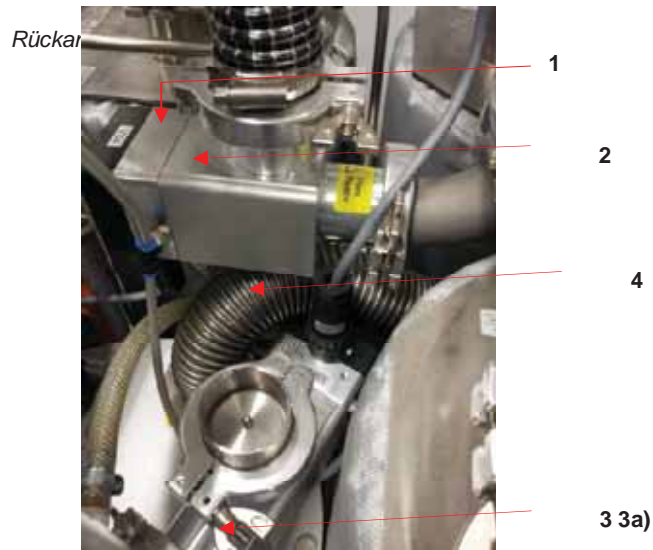

Pos	Beschreibung Description Description	Merkmal Feature Caractéristique	Artikel-Nr. Item no. Article-no
1	PVC-Schlauch (Spülen Ausgang) PVC-Hose (Purging Outlet) Tuyau en PVC (sortie de purge)	800mm	2602195
2	Schlauchklemme Hose clamp Collier pour tuyaux souples	32-50mm	2501116
3	Eckventil HV Angle Valve Vanne à angle droit "	MB-EPV-40 (Al)	9002531-K
		vernickelt, NI-plated, nickelée	9002533-K
3a	Rückschlagventil komplett (Ausgangventil) Non-return valve (Purging out) Clapet anti-retour (vannede sortie)	DN40 komplett	7024588
4	Wie 3 / same as 3 /	--	--

13.2 Inertgas-Box / Inertgas Box / Boîte à gants

13.2.1 Gehäuse MOD (Pro) und Beleuchtung / Chassis and light / Châssis et éclairage (Pro)

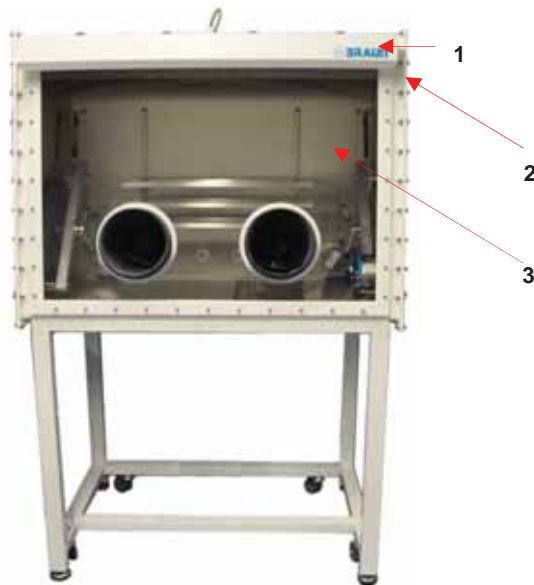

Pos	Beschreibung Description Description	Merkmal Feature Caractéristique	Artikel-Nr. Item no. Article-no
1	Beleuchtung komplett Lightening complete Éclairage complet	L1 - 1200/1250/1500	7070758
		L 2 - 1800/2000	7075061
2	Leuchtstofflampe - Tageslicht weiß Fluorescent lamp - cool white Tube fluorescent - lumière du jour blanche	L1 - 30W	2603476
		L2 - 58W	2603916
3	Scheibe Polycarbonat *) Window polycarbonate Vitre en polycarbonate	MOD-1250	7002195
		MOD-1500	7002448
		MOD-1800	7002443

*) Weitere Artikel bei **MBRAUN** erfragen
 For further articles ask **MBRAUN**
 Autres articles disponibles auprès de **MBRAUN**

Inertgas-Box / Inertgas Box / Boîte à gants

13.2.2 Gehäuse (Plus) und Beleuchtung / Chassis and light / Châssis et éclairage (Plus)



Pos	Beschreibung Description Description	Merkmal Feature Caractéristique	Artikel-Nr. Item no. Article-no
1	Beleuchtung komplett lighting complete éclairage complet	L1	7070758
		L2 / L3	7075061
2	Leuchtstofflampe Fluorescent lamp Lampe fluorescente	L1 30W	2603476
		L2 / L3 58W	2603916
3	Scheibe Polycarbonat Window polycarbonate Vitre en polycarbonate	L1	7002688
		L2	--
		L3	7011242
	Länge der Box Length of the box Longueur de la boîte	[mm]	L1 1200 L3 2000 --

13.2.3 Partikelfilter / Particle Filter / Filtre à particules



Pos	Beschreibung Description Description	Merkmal Feature Caractéristique	Artikel-Nr. Item no. Article-no
1	Partikelfilter Particlefilter Filtre à particules	MB-BF-L-03 (H13)	9004513

Inertgas-Box / Inertgas Box / Boîte à gants

13.2.4 Handschuhe + Zubehör / Gloves and Accessoires / Gants et accessoires

13.2.4.1 Handschuhe / Gloves / Gants



Pos	Beschreibung Description Description	Ø [mm]	Material Material Matériau	Stärke Strength Epaisseur [mm]	Größe Size Taille	Merkmal Feature Caractér.	Artikel-Nr. Item no. Article-no
1	Handschuhe Gloves Gants	220	Brom- Butyl	0,4 1)	Large	A	3000047
				0,4	Large	Y	3240567
				0,4	Medium	A	3000018
				0,8	Large	Y	3240568
				0,8	Large	A	3000048
			Hypalon	0,4	Medium	A	3005010
		0,4		Large	Y	3005009	
		160	Brom- Butyl	0,4	Large	Y	3000051
				0,4	Large	A	3000050
		Oval		0,4	Large	Y	3005008
	Legende Legend Légende	1) Standard Y beidhändig / ambidextrous / ambidextre A anatomisch / anatomical / anatomique					

Handschuhe ohne Talkum : Artikel-Nr. wie oben und – OT (z.B. 3000047-OT)

Gloves without talcum powder : Article No. as above shown and – OT (z.B. 3000047-OT)

Gants sans talc: Numéro d'article ci-dessus et –OT (p.ex. 3000047-OT)

13.2.4.2 Handschuh-Durchführung / Glove Feedthrough / Rond de gant

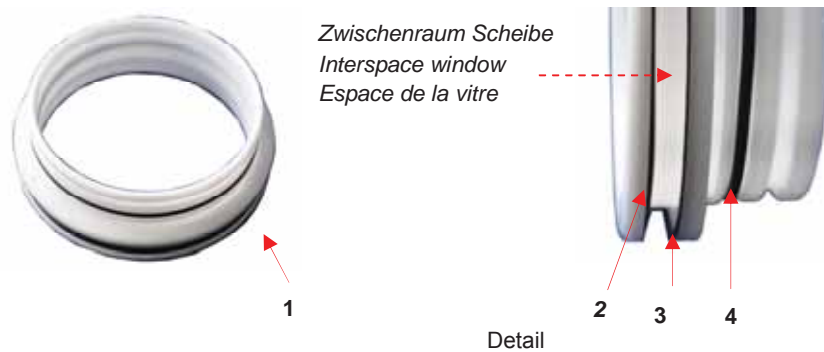

Pos	Beschreibung Description Description	Ø [mm]	Merkmal Feature Caractéristique	Artikel-Nr. Item no. Article-no	
1	Handschuhdurchführung kpl. Gloveport feedthrough cpl. Rond de gant cpl.	220	mit. O-Ringen with O-Rings avec joint toriques	7070842	
		160		9004667	
2	O-Ringe für O-rings for Joint torique	220	innere Handschuhdurchführung inner gloveport feedthrough Rond de gant intérieur	250x4	2400138
3	O-Ringe für O-rings for Joint torique		äußere Handschuhdurchführung outer gloveport feedthrough Rond de gant extérieure	239x7	2603048
4	O-Ringe für O-rings for Joint torique		Befestigung Handschuhe fixation of gloves Fixation de gant	180x6	2600239
		160		140x6	2600240

Weitere Handschuhtypen und O-Ringe können über die **MBRAUN** -Serviceabteilung bestellt werden

Other types of gloves and O-rings can be ordered through the **MBRAUN** Service Department.

D'autres types de gants et joints toriques peuvent être commandés auprès du Service Maintenance **MBRAUN**.

Inertgas-Box / Inertgas Box / Boîte à gants

13.2.4.3 Verschlussdeckel / Port cover / Couvercle

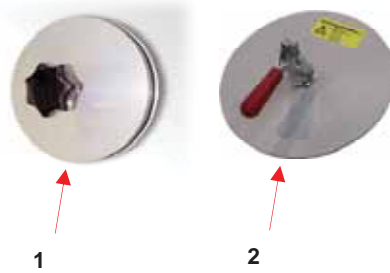

Pos	Beschreibung description description	Ø [mm]	Merkmal feature entité	Artikel-Nr. item no. article-no
1	Innenverschlussdeckel Inner glove port cover Couvercle intérieur pour rond de gant	160		7024831
		220		9002371
2	Außenverschlußdeckel Outer glove port cover Couvercle extérieur pour rond de gant	160		7024791
		220		7019882

13.2.5 Messgeräte / Sensors / Capteurs de mesure

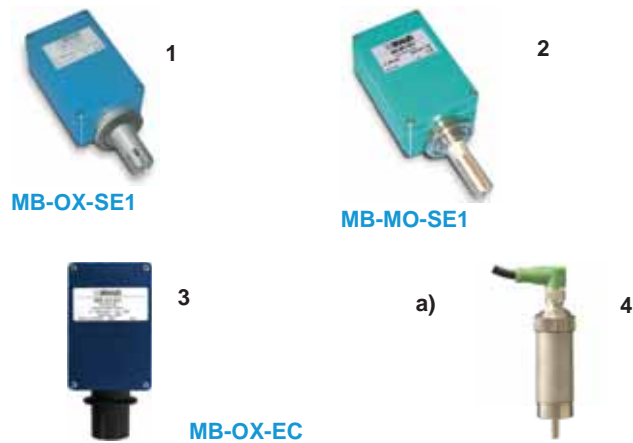

Pos	Beschreibung Description Description	Merkmal Feature Caractéristique	Artikel-Nr. item no. article-no
1	O2 Sensor O2 Sensor Capteur O2	0 – 1000 ppm O2	1500686
1a	blaues Anschlußkabel 10m blue Connection cable 10m	Blue RJ45	2604966-S
2	H2O Sensor H2O Sensor Capteur H2O	0 – 500 ppm H2O	1500685
2a	Grünes Anschlußkabel 10m green Connection cable 10m	Green RJ45	2604967-S
3	O2 Sensor O2 Sensor Capteur O2	0 – 1000 ppm O2	1500716
3a	blaues Anschlußkabel 10m blue Connection cable 10m	Blue RJ45	2604966-S
4	Boxdruck-Sensor Box pressure sensor Capteur de pression de la boîte	+/- 20mbar	4970009
4a)	Sensor-Kabel, geschirmt Actor cable, shielded Câble de raccordement, blindé	M12, 4-polig, 5 m	5008018

Schleusen / Antechambers / Sas

13.3 Schleusen / Antechambers / Sas

13.3.1 Hauptschleuse / Main Antechamber / Sas principal 390 mm

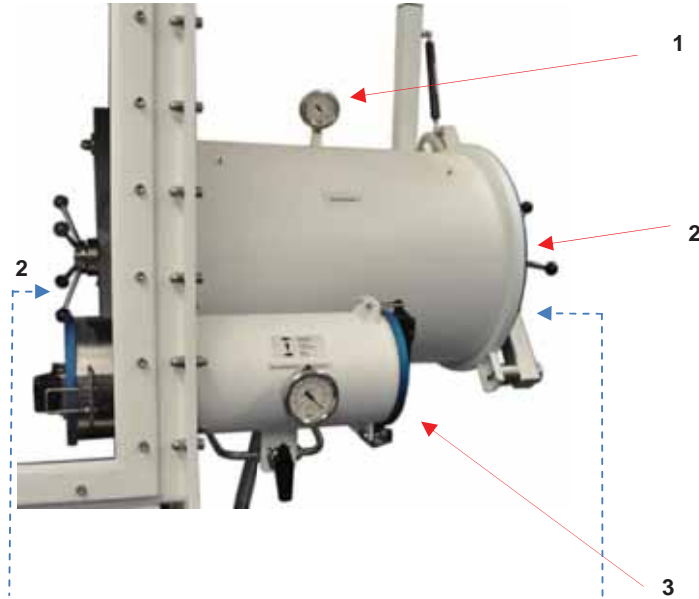

Schleusentür – linke Seite

Schleusentür – rechte Seite

Pos	Beschreibung Description Description	Merkmal Feature Caractéristique	Artikel-Nr. Item no. Article-no
1	Manometer Manomètre Manomètre	G1/4 - VA - 1/0 bar.-100/0 kPa	2405004
2	Schaltkreuz Antechamber door handle Poignée de porte	innen + außen inner + outer en dedans + extérieure	7040131
3	Minischleuse Mini antechamber Mini sas	<i>siehe / see / voir</i> 13.3.2	

Details Schleusendeckel - siehe nächst Seite

Details Antechamber cover - see following page

Détails de la porte du sas - voir page suivante

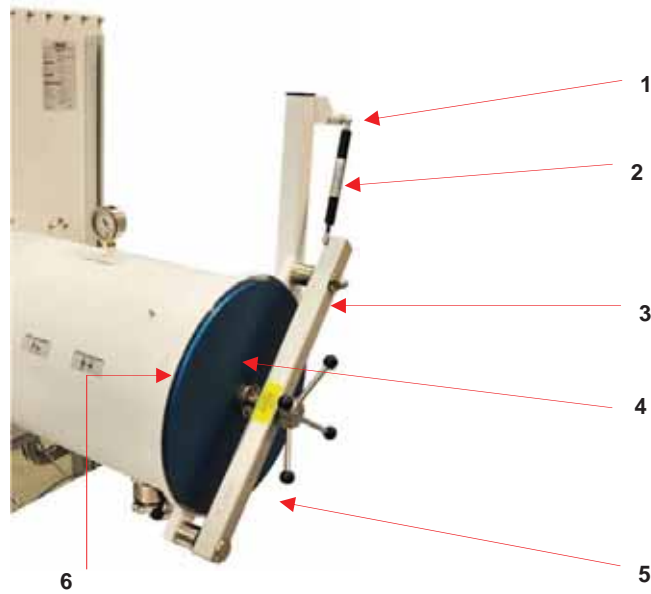

Pos	Beschreibung / Description Description	Merkmal Feature Caractéristique	Artikel-Nr. Item no. Article-no
1	Gewindebuchse / Door shock spacer Douille fileté		7003702
2	Gasdruckfeder 120mm Hub / Gaspiston for antechamber / Amortisseur à gaz	350N 300N (standard)	2179000 3240327
3	Schleusenbalken Türhalter Door arm complete Barre de sas support de porte "	rechts / right / côté droit	6000034
		links / left / côté gauche	6000035
4	Schleusendeckel / Antechamber door Porte de sas		7003674
5	Schleusendeckel komplett *) Antechamber door cover, complete *) Porte de sas complète *) *) mit Schleusendeckel, - balken + Gasdruckfeder *) with antechamber door, - door arm, Doors hock spacer *) avec Porte de sas , Barre de sas, Amortisseur à gaz	Rechts / right côté droit	9005225
		links left côté gauche	9005226
6	O-Ring für Schleusendeckel O-ring for Antechamber Door Joint torique pour porte de sas	Innen und außen Inner and outer intérieur et extérieur)	2400309

Schleusen / Antechambers / Sas

13.3.1.1 Hauptschleuse Handventile / Main antechamber hand valves / Sas principal vanne manuelle



Rückseite / Rear side / à l'arrière

Pos	Beschreibung Description Description	Merkmal Feature Caractéristique	Artikel-Nr. Item no. Article-no
1	Handventil (DN40 VA) Butterfly valve		9004501
2	2-Wege Kugelhahn 3/8" 2-way ball valve 3/8"		3240521
3	Vakuumschlauch Vacuum hose Tuyau à vide	l = 660mm, flexibel	7038898
4	Einschraub-Verschraubung Screwed insert	10mm x 3/8" ISOA konisch	2210047

13.3.1.2 Schleusenautomatik zeitgesteuert/ Automatic AC time-controlled / Sas automatique du temps

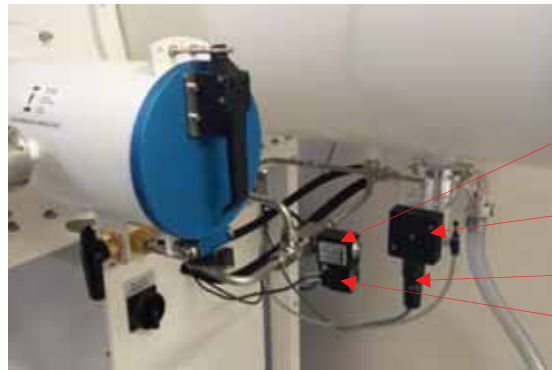

Rückseite / Rear side / à l'arrière

Pos	Beschreibung Description Description	Merkmal Feature Caractéristique	Artikel-Nr. Item no. Article-no
1	Magnetventil Magnetic valve Électrovanne	2/2-Wege / ways / à voies 0-8 bar	4600977
2	Eckventil Angel Valve Vanne à angle droit	MB-EPV-40 (Al)	9002531-K
	Eckventil Angel Valve Vanne à angle droit	MB-EPV-40 vernickelt / Ni-plated / nickelé	9002533-K
3	Ventilbuchsenstecker mit Kabel	7-pol. EPV40, l = 4m	5006151
4	Ventilsteckverbinder	2-pol, LED, l = 4,6m	5006097

Schleusen / Antechambers / Sas

13.3.1.3 Schleusenautomatik / Automatic AC / Sas automatique

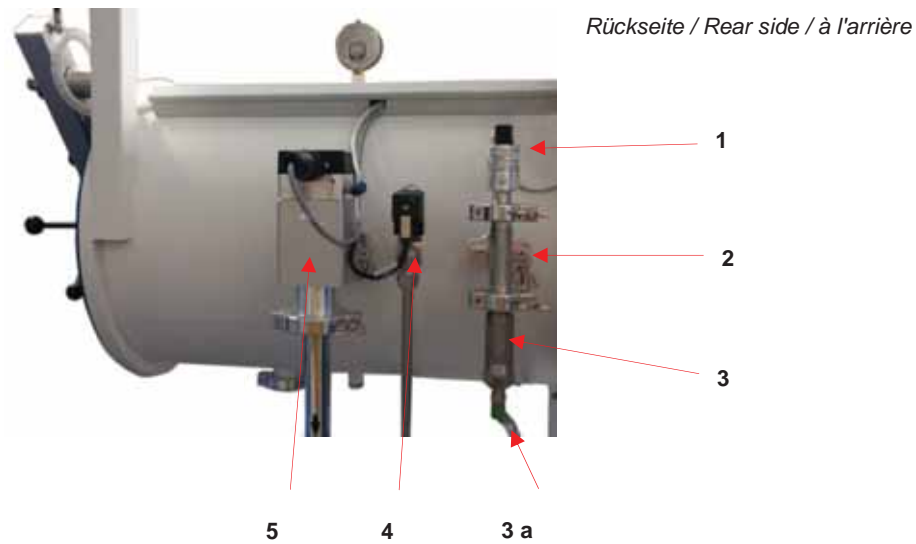

Pos	Beschreibung Description Description	Merkmal Feature Caractéristique	Artikel-Nr. Item no. Article-no
1	Pirani Messröhre Vacuum pirani sensor Jauge de mesure Pirani	0..1000 mbar	3226006
2	T-Stück T-Piece Raccord en T	DN16 ISO-KF Alu / Alloy / inox	3201024
	"	DN16 ISO-KF Edelstahl / Stainless steel /inox	3201050
3	Atmosphären-Drucksensor Atmospheric pressure sensor Capteur de pression atmosphérique	-1000..636 mbar, 1..10V	4970007
3 a	Anschlusskabel Connection cable Câble de raccordement	M12, 5 m	5008018
4	Magnetventil Magnetic valve Électrovanne	2/2-Wege / ways / à voies 0-8 bar	4600977
5	Eckventil Angel Valve Vanne à angle droit	MB-EPV-40 (Al)	9002531-K
5	Eckventil Angel Valve Vanne à angle droit	MB-EPV-40 vernickelt / Ni-plated / nickelé	9002533-K

13.3.2 Minischleuse / Mini Antechamber / Mini Sas 150 mm

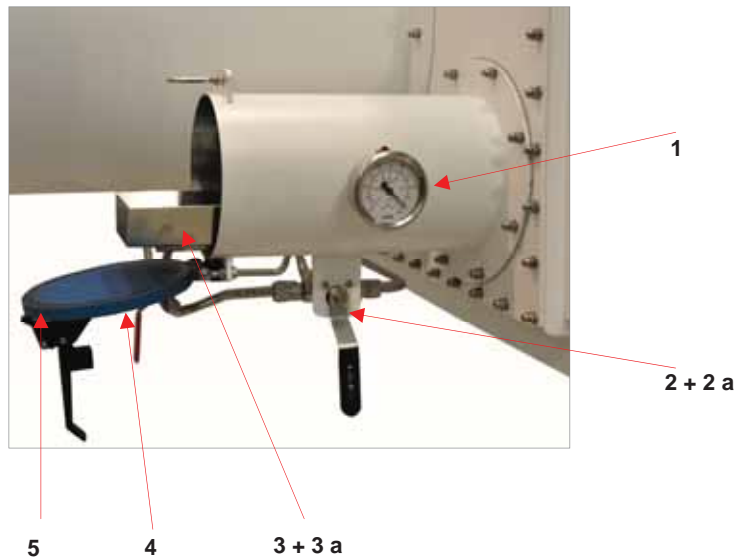

Pos	Beschreibung Description Description	Merkmal Feature Caractéristique	Artikel-Nr. Item no. Article-no
1	Manometer Manometer Manomètre	0/-1bar	3240762
2	3-Wege-Kugelhahn 3-Way Ball Valve Robinet à boisseau sphérique 3 voies	3/8 "	2210480
		<i>Unilab / Labstar:</i>	2603906
2a	Anlaufscheibe Washer disk Rondelle de friction		2602336
3	Tablett Tray Tiroir coulissant		7075485
3a	Teleskopschiene Rail, Telescopic Rail télescopique		7077301
4	Schleusendeckel Cover mini antechamber Porte de sas complète	komplett complete complet	7077293
5	Profildichtung Gasket Joint profilé	flach flat à plat	7077297

Vakuumpumpe / Vacuum Pump / Pompe à vide

13.4 Vakuumpumpe / Vacuum Pump / Pompe à vide

13.4.1 Standard

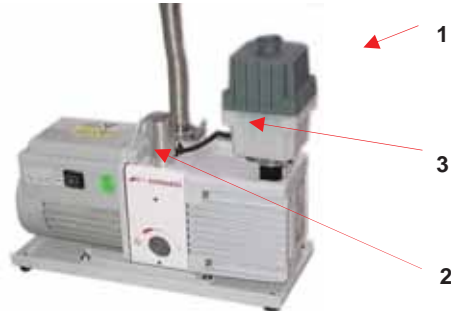

Pos	Beschreibung Description Description	Merkmal Feature Caractéristique	Artikel-Nr. Item no. Article-no
1	Vakuumpumpe Vacuum Pump Pompe à vide	RV12	3240487
2	Gasballast-Ölrückführung Gas ballast oil return Gaz ballast et retour d'huile	RV3-RV12	3240540
3	Ölfiter Oil Mist Filter Filtre à brouillard d'huile	EMF20	3240539

13.4.2 Upgrade: Tri-Scroll-Vakuumpumpe / Vacuum pump / Pompe à vide



Option: Spülkit / Purge Kit / Kit de purge
s. 13.4.2.1

Pos	Beschreibung Description Description	Merkmal Feature Caractéristique	Artikel-Nr. Item no. Article-no
1	Vakuumpumpe Vacuum Pump Pompe à vide	TriScroll PTS 310,1 1-phasig / single phase / monophasée	2193001
	"	3-phasig / three phases / triphasé	2193000

13.4.2.1 Tri-Scroll-Pumpe / pump / pompe: Spülkit / Purge kit / Kit de purge

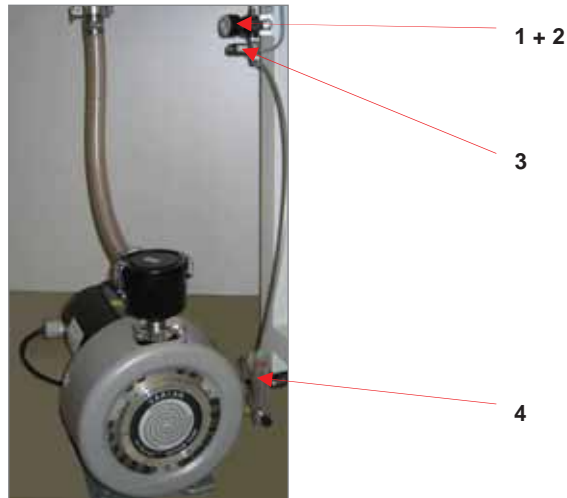

Beispiel / Example

Pos	Beschreibung Description Description	Merkmal Feature Caractéristique	Artikel-Nr. Item no. Article-no
1	Manometer Manomètre Manomètre	0..1 bar	4601278
2	Druckregler Pressure controller Régulateur de pression	1/8"; 0,1-0,7 bar entlüftend / de-airing / désaération	4601276
3	Magnetventil Magnetic Valve Électrovanne	A-02,4	3210017
4	Spülkit (Durchflußmesser + Anbauteile) Purge kit Kit de purge	für TriScroll-Pumpe for TriScroll Pump pour pompe TriScroll	3000053

Steuerung / Controlling / Commande

13.5 Steuerung / Controlling / Commande

13.5.1 Bedienpanel / Operation Panel / Écran tactile

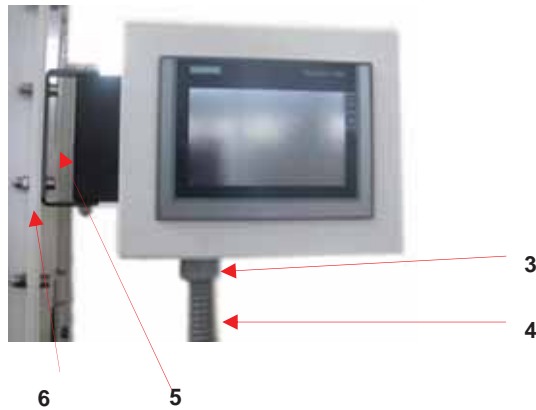

Pos	Beschreibung description description	Merkmal feature entité	Artikel-Nr. item no. article-no
1	Bedienpanel Touch Panel Ecran tactile	a) TP700 (Labmaster, MB20-200)	2605141
		b) TFT70 (Unilab, Labstar)	7107449
2	Gehäuse für Bedienpanel Cabinet for Touch panel Boîtier de panneau de commande	Rechts / Links Right/Left) à droite/à gauche	7023898
3	Schlauchverschraubung Straight grommet Raccord à vis pour tuyau		2600272
4	Kabelschuttschlauch Gray wire track Gaine de protection des câbles		5003044
5	Panelhalter Metallbügel Metal bracket Support du panneau		7070745
6	Panelhalter – Kunststoff Plastic OP bracket Pièce intermédiaire		7070761

13.5.2 Fußschalter / Foot Switch / Pédalier



Pos	Beschreibung Description Description	Merkmal Feature Caractéristique	Artikel-Nr. Item no. Article-no
1	Fußschalter Foot switch Pédalier		5007021

13.6 Option : Kühlschrank / Refrigerator / Congélateur

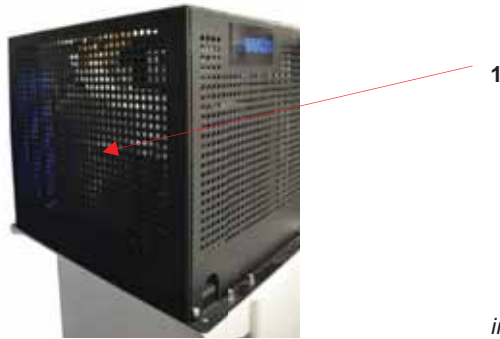

innen / inside / intérieur:

Pos	Beschreibung description description	Merkmal feature entité	Artikel-Nr. item no. article-no
1	Kompressor Compressor Compresseur	MB GS-35 - 230V 50Hz	2600996
	Nur für Nachrüstungen / Only for Upgrade Kits		
	Temperaturregler Temperature controller Régulateur de temperature	Kit Beta Elektronik Freistehende Einheit Stand-Alone-Unit Stand-Alone-Systeme	2600530

14.1 Overview.....14-2

Overview

14 Third Party Documentation

14.1 Overview

No.	Hersteller	Art.Nr. MBraun	Beschreibung	Typ	Sprache	PDF ¹⁾
1	BOC Edwards	3240487	Rotary Vane Pump	RV3/5/8/12 A652-01-882	English	x
2		3240539	Oil Mist Filters	EMF3, EMF10, EMF 20 A462-26-880	English	x
3		3240540	EMF Adjustable Gas Ballast Oil Drain Kit for RV3 to RV12 Pumps	A505-23-882	English	x
4		-----	Vacuum Leadthroughs and Accessories	Model 6EK25, 7EK10, 10EK25, TL8K25, Earth Electrical Leadthrough, Model 4RK 10, 8RK25, 12RK25 Rotary Shaft Vacuum Seal 6EK25, 10EK25 Extension Accessory, Type 10, 25 Blanking Plug E-100-99-880	English	x
5	Jumo	4970009	Pressure Sensor	24VDC +/- 20 mbar	Multilingual	x
6	MBRAUN SEW Eurodrive	2700636	Parameter Settings for Frequency Inverter	LTE-B 200-240V	English	x

1) PDF files see CD-ROM or USB-Stick (Annex)

15.1 Overview15-2

Overview

15 Certificates

15.1 Overview

N°	Manufacturer	Description	Type	Language
1	MBRAUN	CE-Declaration	UNIlab Pro/Plus sp/dp	English
2				
3				

16.1 Safety when handling the electrics of the system	16-2
16.1.1 <i>Basic rules</i>	16-2
16.1.2 <i>Control cabinet</i>	16-3
16.1.3 <i>Work on the electrical system</i>	16-3
16.1.4 <i>Electrical safety check</i>	16-3
16.2 Wiring Diagrams.....	16-4

16 Electrical system & wiring diagrams

16.1 Safety when handling the electrics of the system

**DANGER!**

Risk of personal injury due to electrical voltage in case of error: uncontrolled muscle reactions, crippling, burns or death can result!

- ▶ All work on the mains connection, the control cabinet and the electrical system may only be performed by a trained electrician.

In case of electrical shock, inform the emergency physician immediately

Emergency OFF

If components are integrated into the **MBRAUN** system and equipped with an EMERGENCY OFF switch, please follow the note below:

**DANGER**

Personal injury and environmental damage due to incorrect operation!

An EMERGENCY OFF of third-party components switches off only these components!

- ▶ In case of danger, switch off the main switch on the system's control cabinet!
-

16.1.1 Basic rules

- The system must be grounded at all times. If necessary, additional potential equalisation must be provided (see chap. Installation and wiring diagrams)
- The mains connection must be made according to local guidelines.
- Modifications to the electrical system must be made in agreement with **MBRAUN**
- Modifications to the electrical system must always be documented in the wiring diagram

16.1.2 Control cabinet



DANGER

Risk of personal injuries due to electrical voltage in case of error:

- The system may not be operated with an open control cabinet door!

- ▶ Only a trained electrician may open the control cabinet.

Before opening the control cabinet and starting work on the electrical system

- ▶ Switch off the main switch
- ▶ Or: remove the mains plug from the outlet or de-energise the mains connection!
- ▶ Secure it against being switched on again.

16.1.3 Work on the electrical system

Before working on the electrical system:

- ▶ Measure potential

The system must be de-energized!

16.1.4 Electrical safety check

After each change to the electrical systems / maintenance and repair, perform an electrical test.



Cyclical testing is due according to BGV A3 / national operational safety regulations or in-house regulations.

- ▶ Document the inspection performed in the **MBRAUN** maintenance log
- ▶ Compare the measured values with the data from the Initial test to evaluate the test result.

Wiring Diagrams

16.2 Wiring Diagrams

Included on CD supplied with system

Contact **MBRAUN** Service for assistance



M. Braun Inc.
14 Marin Way
Stratham, NH 03885

Tel.: +1 (603) 773-9333 • Fax: +1 (603) 773-0008
E-Mail: info@mbraunusa.com • Internet: www.mbraun.com