

**Model 600E Series
Electrochemical Analyzer/Workstation
User Manual**

 CH Instruments

CH Instruments Model 600E Series User Manual

© 2012 CH Instruments, Inc.

All rights reserved. No parts of this work may be reproduced in any form or by any means - graphic, electronic, or mechanical, including photocopying, recording, taping, or information storage and retrieval systems - without the written permission of the publisher.

Products that are referred to in this document may be either trademarks and/or registered trademarks of the respective owners. The publisher and the author make no claim to these trademarks.

While every precaution has been taken in the preparation of this document, the publisher and the author assume no responsibility for errors or omissions, or for damages resulting from the use of information contained in this document or from the use of programs and source code that may accompany it. In no event shall the publisher and the author be liable for any loss of profit or any other commercial damage caused or alleged to have been caused directly or indirectly by this document.

Printed: November 2012 in Austin, Texas.

Table of Contents

Chapter 1 General Information	1
1.1 Introduction	2
1.2 Electrochemical Techniques.....	4
1.3 Software Features.....	6
1.4 System Requirements.....	9
1.5 Hardware Specifications.....	10
Chapter 2 Getting Started	11
2.1 Installation	12
2.2 USB Driver Installation.....	16
2.3 Testing	19
2.4 Some Useful Tips.....	20
Chapter 3 File Menu	21
3.1 Open command.....	22
3.2 Save As command.....	24
3.3 Delete command.....	25
3.4 Retrieve command.....	26
3.5 Update Instrument Program command.....	27
3.6 List Data File command.....	28
3.7 Convert to Text command.....	29
3.8 Text File Format command.....	30
3.9 Import Text File command.....	33
3.10 Print command.....	34
3.11 Print Multiple Files command.....	35
3.12 Print Setup command.....	36
3.13 Exit command.....	37
Chapter 4 Setup Menu	39
4.1 Technique command.....	40
4.2 Parameters command.....	41
4.2.1 Cyclic Voltammetry Parameters dialog box	42
4.2.2 Linear Sweep Voltammetry Parameters dialog box	44
4.2.3 Staircase Voltammetry Parameters dialog box	46
4.2.4 Tafel Plot Parameters dialog box	47
4.2.5 Chronoamperometry Parameters dialog box	48
4.2.6 Chronocoulometry Parameters dialog box	50
4.2.7 Differential Pulse Voltammetry Parameters dialog box	52
4.2.8 Normal Pulse Voltammetry Parameters dialog box	53
4.2.9 Differential Normal Pulse Voltammetry dialog box	54

4.2.10	Square Wave Voltammetry Parameters dialog box	55
4.2.11	AC Voltammetry Parameters dialog box	56
4.2.12	2nd Harmonic AC Voltammetry Parameters dialog box	57
4.2.13	FT AC Voltammetry Parameters dialog box	58
4.2.14	Amperometric i-t Curve dialog box	59
4.2.15	Differential Pulse Amperometry dialog box	60
4.2.16	Double Differential Pulse Amperometry dialog box	61
4.2.17	Triple Pulse Amperometry Parameters dialog box	63
4.2.18	Integrated Pulsed Amperometric Detection Parameters dialog box	65
4.2.19	Bulk Electrolysis with Coulometry Parameters dialog box	67
4.2.20	Hydrodynamic Modulation Voltammetry Parameters dialog box	68
4.2.21	Sweep Step Function Parameters dialog box	69
4.2.22	Multi-Potential Steps Parameters dialog box	70
4.2.23	A.C. Impedance Parameters dialog box	71
4.2.24	Impedance - Time Parameters dialog box	73
4.2.25	Impedance - Potential Parameters dialog box	74
4.2.26	Chronopotentiometry Parameters dialog box	75
4.2.27	Chronopotentiometry with Current Ramp Parameters dialog box	77
4.2.28	Multi-Current Steps Parameters dialog box	78
4.2.29	Potentiometric Stripping Analysis Parameters dialog box	79
4.2.30	Parameters for Electrochemical Noise Measurement dialog box	80
4.2.31	Parameters for Open Circuit Potential vs Time dialog box	81
4.3	System command.....	82
4.4	Hardware Test command.....	85

Chapter 5 Control Menu 87

5.1	Run Experiment command.....	88
5.2	Pause / Resume command.....	89
5.3	Stop Run command.....	90
5.4	Reverse Scan command.....	91
5.5	Zero Current command.....	92
5.6	Zero Time command.....	93
5.7	Run Status command.....	94
5.8	Repetitive Runs command.....	97
5.9	Multiplexer command.....	98
5.10	Macro Command command.....	100
5.11	Open Circuit Potential command.....	107
5.12	iR Compensation command.....	108
5.13	Filter Setting command.....	110
5.14	Cell command.....	112
5.15	Step Functions command.....	115
5.16	Preconditioning command.....	116
5.17	Rotating Disk Electrode command.....	117
5.18	Other command.....	118
5.19	Stripping Mode command.....	119

Chapter 6 Graphics Menu	121
6.1 Present Data Plot command.....	122
6.2 Overlay Plots command.....	126
6.3 Add Data to Overlay command.....	127
6.4 Parallel Plots command.....	128
6.5 Add Data to Parallel command.....	129
6.6 Zoom In command.....	130
6.7 Manual Results command.....	131
6.8 Peak Definition command.....	132
6.9 X-Y Plot command.....	133
6.10 Peak Parameter Plot command.....	135
6.11 Semilog Plot command.....	136
6.12 Special Plot command.....	137
6.13 Graph Options command.....	138
6.14 Color and Legend command.....	141
6.15 Font command.....	143
6.16 Copy to clipboard command.....	144
Chapter 7 DataProc Menu	145
7.1 Smoothing command.....	146
7.2 Derivatives command.....	148
7.3 Integration command.....	149
7.4 Semiinteg and Semideriv command.....	150
7.5 Interpolation command.....	151
7.6 Baseline Fitting & Subtraction command.....	152
7.7 Linear Baseline Correction command.....	154
7.8 Data Point Removing command.....	155
7.9 Data Point Modifying command.....	156
7.10 Background Subtraction command.....	157
7.11 Signal Averaging command.....	158
7.12 Mathematical Operation command.....	159
7.13 Fourier Spectrum command.....	160
Chapter 8 Analysis Menu	161
8.1 Calibration Curve command.....	162
8.2 Standard Addition command.....	164
8.3 Data Report command.....	166
8.4 Time Dependence command.....	168
8.5 Special Analysis command.....	170

Chapter 9 Sim Menu	171
9.1 Mechanism command.....	172
9.1.1 Digital Simulation dialog box	173
9.1.2 Potentials and Rate Constants dialog box	176
9.1.3 Concentration and Diffusion Coefficients dialog box	177
9.1.4 Surface Concentration dialog box	178
9.1.5 Concentration at Equilibrium dialog box	179
9.1.6 Simulation Variables dialog box	180
9.2 CV Simulate command.....	181
9.3 AC Impedance Simulator and Fitting Program	182
9.4 CV Fitting command.....	186
Chapter 10 View Menu	189
10.1 Data Information command.....	190
10.2 Data Listing command.....	192
10.3 Equations command.....	193
10.4 Clock command.....	194
10.5 Toolbar command.....	195
10.6 Add or Remove Buttons command.....	196
10.7 Status Bar command.....	197
Chapter 11 Help Menu	199
11.1 Help Topics command.....	200
11.2 About command.....	201
Chapter 12 Appendix	203
12.1 Cables and Connections.....	204
12.2 Firmware Update Instructions.....	206
12.3 Troubleshooting.....	207
12.4 Maintenance and Service.....	208
12.5 Limited Warranty.....	209
12.6 Safety	210
12.7 Abbreviations of Electrochemical Techniques.....	212
12.8 Model 400B Series Time-Resolved Electrochemical Quartz Crystal Microbalance.....	213
12.9 Model 600E Series Electrochemical Analyzer Techniques.....	215
12.10 Model 700E Series Bipotentiostat Techniques.....	216
12.11 Model 800C Series Electrochemical Detector Techniques.....	217
12.12 Model 920D Scanning Electrochemical Microscope.....	218
12.13 Model 1000C Series Multi-Potentiostat.....	220
12.14 Model 1100C Series Power Potentiostat / Galvanostat.....	222
12.15 Model 1200B Series Handheld Potentiostat / Bipotentiostat.....	224

12.16	Pico-Liter Solution Dispenser.....	225
12.17	Picoamp Booster/Faraday Cage and Multiplexer.....	227
12.18	Amp Booster and Liquid/Liquid Interface Adapter.....	229
12.19	Accessories.....	230

Chapter 1 General Information

This chapter contains general information about your instrument.

- Introduction
- Electrochemical
Techniques
- Software Features
- System Requirements
- Hardware Specifications

1.1 Introduction

The model 600E series instrument is a computerized general purpose potentiostat / galvanostat. The Figure below shows the block diagram of the instrument. The system contains a fast digital function generator, a direct digital synthesizer for high frequency ac waveforms, high-speed dual-channel data acquisition circuitry, a potentiostat and a galvanostat (select models). The potential control range is $\pm 10\text{V}$ and the current range is $\pm 250\text{mA}$. The instrument is capable of measuring current down to picoamperes. The instrument is very fast. The function generator can update at a 10 MHz rate. Two high speed and high resolution data acquisition channels allow both current and potential (or an external voltage signal) to be sampled simultaneously at a rate of 1 MHz, with 16-bit resolution. The instrument provides a very wide dynamic range of experimental time scales. For instance, the scan rate in cyclic voltammetry can be up to 1000V/s with a 0.1 mV potential increment or 5000 V/s with a 1 mV potential increment. The potentiostat / galvanostat uses a 4-electrode configuration, allowing it to be used for liquid/liquid interface measurements, and eliminating the effect of the contact resistance of connectors and relays for high current measurements. The data acquisition systems also allow an external input signal (such as spectroscopic) to be recorded simultaneously during an electrochemical measurement.

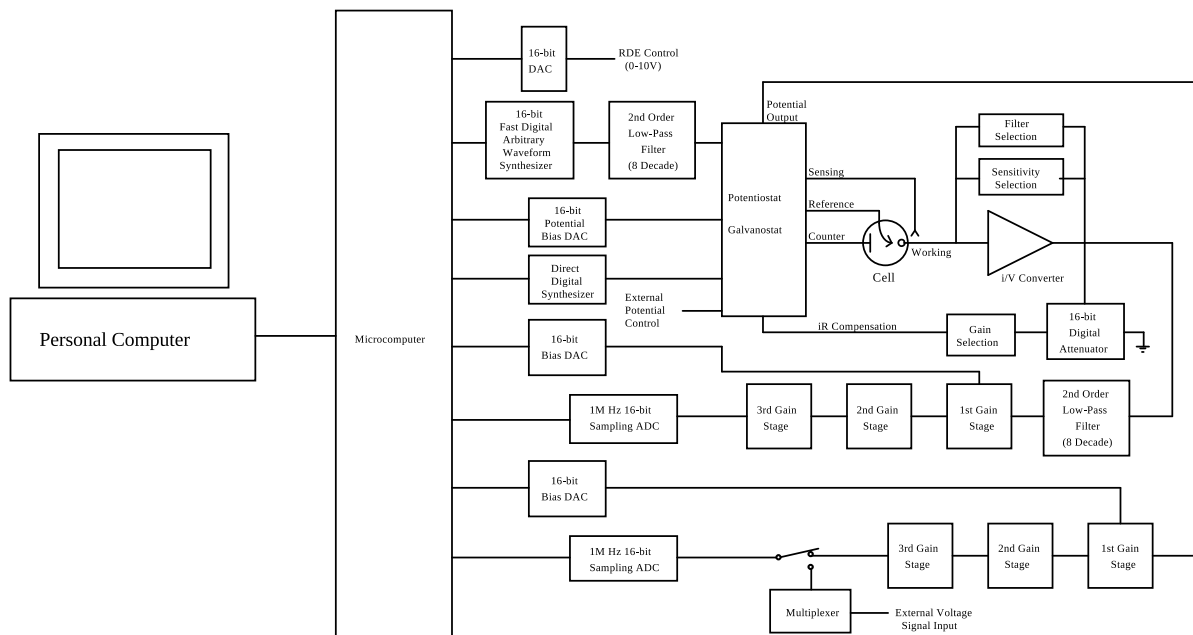

The multiplexed data acquisition system of the instrument allows an external input, such as a spectroscopy signal, to be recorded simultaneously with electrochemical data. The instrument will also automatically re-zero both potential and current to compensate for hardware drift due to temperature and time, making periodic re-calibration of the instrument unnecessary.

The instrument can be controlled by any PC running Windows 98 or higher. It is easy to install and use. The user interface uses the classic Microsoft design, so if you are familiar with Windows applications, you can likely use the software without referring at all to this user manual or the comprehensive, context-sensitive help files that are included with the instrument software. The commands, parameters, and options have been written using terminology that most chemists are familiar with. A customizable toolbar allows quick access to the most commonly used commands.

The instrument provides many powerful functions, such as straightforward file handling, extensive experimental control, flexible graphics, various data analyses, and efficient digital simulation. Additional features include macro commands, working electrode conditioning, color, legend and font

selection, data interpolation, visual baseline correction, data point removal, visual data point modification, signal averaging, Fourier spectrum, and a convenient technique-specific electrochemical equation viewer.

This model series includes a USB port (default) and a serial port for data communication with the PC, with hot-switching capabilities available on the rear panel of the instrument. Firmware is now stored in flash memory, and as a result, instrument firmware upgrades can be downloaded electronically and installed immediately, instead of the inconvenient shipment and installation of EPROM chips.

Highly stable 16-bit bias circuitry is used for current and potential bias, allowing a wider dynamic range in AC measurements. This can also be used to re-zero the DC current output.

The major improvements in the 600E series are very stable and accurate potential and current control, and dual channel data acquisition at high speed.

This model series also includes a true integrator for chronocoulometry, and is capable of waveform update at 10 MHz and data acquisition at 1 MHz with 16-bit resolution and low noise.

The model 600E series can be upgraded to the corresponding 700E series model bipotentiostat with an add-on board that includes circuitry for the second channel's potential control, current measurement (including sensitivity switching), two low-pass filters, three gain stages, and channel selection. It is therefore identical to the 600E series when used for single-channel measurements. When it is used as a bipotentiostat, the second channel can be controlled at a independent constant potential, to scan or step at the same potential as the first channel, or to scan with a constant potential difference with the first channel. The second channel is available for many voltammetric and amperometric techniques.

1.2 Electrochemical Techniques

Sweep Techniques

- Cyclic Voltammetry
- Linear Sweep Voltammetry
- Rotating Disk Electrode Voltammetry
- Tafel Plot
- Sweep-Step Functions

Step Techniques

- Chronoamperometry
- Chronocoulometry
- Staircase Voltammetry
- Fast Polarography
- Differential Pulse Voltammetry and Polarography
- Normal Pulse Voltammetry and Polarography
- Differential Normal Pulse Voltammetry and Polarography
- Square Wave Voltammetry
- Sweep-Step Functions
- Multi-Potential Steps

A.C. Techniques

- A.C. Voltammetry and Polarography
- Phase-selective A.C. Voltammetry and Polarography
- Second Harmonic A.C. Voltammetry and Polarography
- A.C. Impedance Spectroscopy
- A.C. Impedance versus Time
- A.C. Impedance versus Potential

Stripping Techniques

- Linear Sweep Stripping Voltammetry
- Differential Pulse Stripping Voltammetry
- Normal Pulse Stripping Voltammetry
- Square Wave Stripping Voltammetry
- A.C. Stripping Voltammetry
- Phase-selective A.C. Stripping Voltammetry
- Second Harmonic A.C. Stripping Voltammetry

Controlled-Current Techniques

- Chronopotentiometry
- Chronopotentiometry with Current Ramp
- Multi-Current Steps
- Potentiometric Stripping Analysis

Amperometric Detection Techniques

- Amperometric i - t Curve
- Differential Pulse Amperometry
- Double Differential Pulse Amperometry
- Triple Pulse Amperometry
- Integrated Pulse Amperometric Detection

Other Techniques

- Bulk Electrolysis with Coulometry

- Hydrodynamic Modulation Voltammetry
- Electrochemical Noise Measurement
- Open Circuit Potential - Time

1.3 Software Features

User Interface

- *Unicode tabbed-document application*: compatible with 32- and 64-bit Windows
- *monolithic architecture*: minimal installation footprint and portable design bypasses the Windows registry
- *multiple instances*: control multiple instruments by simply duplicating the program
- *customizable toolbar*: quick access to your most frequently used commands
- *complete, intuitive environment*: run experiments, analyze data, and generate plots all in the same window
- *dockable toolbar*: quick graphical access to the most commonly used commands
- *status bar*: technique, file status, and command prompt
- *WYSIWYG graphics*
- *comprehensive context-sensitive help*

File Management

- *Unicode support*: international file and folder names
- *open data files*: read directly from binary or plain-text files
- *save data file*: binary, plain-text formats for exporting data (e.g., to spreadsheet)
- *list data file*
- *convert to text files*: for exporting multiple data files
- *text file format*
- *print present data*
- *print multiple data files*
- *print setup*

Experimental Setup

- *technique*: a large repertoire of electrochemical techniques
- *experimental parameters*: extremely wide dynamic range
- *system setup*: line frequency, potential/current axis polarities
- *hardware test*: digital and analog circuitry diagnostic test

Instrument Control

- *run experiment*: real time data display in most cases
- *pause/resume during run*
- *stop running experiment*
- *reverse CV scan direction during run*
- *repetitive runs*: automatic data save, signal averaging, delay or prompt
- *run status*: stir, purge, smooth after run, iR compensation, RDE and SMDE control status
- *macro commands*: edit, save, read, and execute any series of commands
- *open circuit potential measurement*
- *working electrode conditioning before running experiment*
- *analog filter settings*: automatic or manual setting of i/V converter, potential, and signal filters
- *stripping mode*: enable/disable, deposition potential and time, stir and purge conditions
- *cell control*: purge, stir, cell on, SMDE drop collection, pre-run drop knock, and stabilizing capacitor
- *rotating disk electrode (select models)*: rotation speed, on/off control during deposition, quiescent time, run, and between runs
- *step functions*: multiple cycles of step function generator, for electrode cleaning or other purposes
- *iR compensation*: automatic and manual compensation, solution resistance, double layer capacitance and stability test

Graphical Display

- *present data plot*: data plot with header, filename, parameters, and results

- *re-scaling and labeling*: axis expression, re-scaling, and text insertion
- *overlay plots*: plot multiple data sets on the same graph for comparison
- *parallel plots*: plot multiple data sets side by side for comparison
- *zoom in*: visually selected zoom area
- *manual results*: visually selected baseline
- *peak definition*: shape, width, and report options
- *X-Y Plot*: import arbitrary data sets
- *peak parameter plot*: $ip \sim v$, $ip \sim v^{1/2}$, $Ep \sim \log(v)$ plots
- *semilog plot*: current-potential semilog plot
- *graph options*: display or printer options, axis, parameters, baseline, results, grids, axis inversion, axis freeze, axis titles, data sets, XY scales, reference electrode, header, and notes
- *color and legend*: background, axis, grid, curves, legend size, thickness, and display intervals
- *font*: font, style, size, and color of axis labels, axis titles, header, parameters, and results
- *copy to clipboard*: for pasting graphics in third-party applications (word processors, etc.)
- *3d plotting (NEW)*: interactive visualization of impedance data

Data Processing

- *smoothing*: 5-49 point least square and Fourier transform
- *derivatives*: 1st - 5th order, 5-49 point least square
- *numerical integration*
- *convolution*: semi-derivative and semi-integral
- *interpolation*: $2\times$ - $64\times$ data interpolation
- *baseline fitting and subtraction*: selectable fitting function, polynomial order and potential range for best fitting and baseline subtraction; particularly useful for trace analysis
- *linear baseline correction*: visually selected baseline, slope, and DC level compensation
- *data point removal*
- *data point modification*: visual data point modification
- *background subtraction*: difference between two data sets
- *signal averaging*: averaging multiple sets of data
- *mathematical operations*: both X and Y data arrays
- *Fourier spectrum*

Analysis

- *calibration curves*: calculate the unknown concentration and the slope, intercept, and correlation of the curve; plot the calibration curve; save and read the calibration data
- *standard addition*: calculate the unknown concentration and the slope and correlation of the standard addition curve; plot the standard addition curve; save and read the standard addition data
- *data file report*: calculate the unknown concentration from saved data files based on user-defined peak potential range, species, and calibration information; generate analytical report in text format; up to four species of interest
- *time dependence*: calculate the unknown concentration as a function of time from saved data files based on user-defined peak potential range and calibration information; report and/or plot concentration as a function of time
- *corrosion rate calculation*

CV Simulation and Fitting

- *fast implicit finite difference algorithm*
- *reaction mechanisms*: 10 predefined mechanisms; any combination involving electron transfer, first- and second-order chemical reactions
- *system*: diffusive or adsorptive
- *maximum equations*: 12
- *maximum species*: 9
- *simulation parameters*: standard redox potential, rate of electron transfer, transfer coefficient,

concentration, diffusion coefficient, forward and reverse chemical reaction rate constants, temperature, electrode area, and experimental parameters

- *save simulation parameters*
- *read simulation parameters*
- *real-time display of simulation data, concentration profiles*
- *dimensionless current*
- *equilibrium data*
- *automatic detection and calculation of over-determined equilibrium constants*

AC Impedance Simulation and Fitting

- *visually equivalent circuit input*
- *automatic equivalent circuit parameters fitting*

View

- *data information:* date, time, filename, data source, instrument model, data processing performed, header and notes
- *data listing:* data information and numerical data array
- *equations:* convenient compilation of general and technique-specific equations
- *clock*
- *toolbar*
- *status bar*

Help

- *comprehensive context-sensitive HTML help*
- *on-the-fly switching between HTML help and legacy WinHelp*
- *using help*
- *about the application*

1.4 System Requirements

Operating System: Windows 98 / NT / Me / 2000 / XP / Vista / 7 / 8

Communication between PC and instrument: USB or RS-232 serial port

Output device: any printer or plotter supported by Windows

1.5 Hardware Specifications

Potentiostat, Galvanostat (select models)

Potential: ± 10 V

Current: ± 250 mA

Compliance Voltage: ± 12 V

Potentiostat rise time: < 1 μ s

Four-Electrode Configuration

Input Impedance of Reference Electrode: 10^{12} Ω

Minimum Potential Increment in Sweep Techniques: 100 μ V

Potential Update Rate: 10 MHz

Potential Scan Rate: $10,000$ V/s

Maximum Sampling Rate: 1 MHz (16-bit)

Current Measurement Range: 10^{-12} - 0.1 A/V in 12 ranges

True integrator for chronocoulometry

Input Bias Current: below 20 pA

Low Current Measurability: below 1 pA

Automatic Re-zeroing: both potential and current against drift

Cell Control: purge, stir, and knock

RDE Rotation Rate Control: 0 - 10 V voltage output for 0 - 10000 rpm

Instrument Dimensions: 14.2 " (W) \times 9.2 " (D) \times 4.6 " (H)

Weight: ~ 12 lb.

Chapter 2 Getting Started

This chapter contains information about how to get started using your instrument.

Installation

Testing

Some Useful Tips

USB Driver Installation

2.1 Installation

Important Note

After you unpack the instrument, please check the contents of the shipment carefully. You should find the instrument, USB cable, electrode leads, software CD-ROM, and a printed copy of this User Manual. Electrodes and other accessories are sold separately; if you ordered electrodes and accessories, please thoroughly check the shipment and compare its contents with the packing list. If anything is missing, please search thoroughly inside the container, since the missing items may have been mixed with the packing material over the course of shipping. Please report any missing or damaged items immediately and do not throw away the shipping materials, as these may be used for return shipping.

Software

The instrument can be controlled by any PC running Windows 98 / NT / Me / 2000 / XP / Vista / 7 / 8. A free USB port or serial port is required for communication between the instrument and the PC. Refer to your Windows system documentation to gain familiarity with Windows operation.

Windows Vista can control the instrument properly, but will sometimes can experience graphical glitches. The program may paint single pixel dots incorrectly or leave entire areas of the screen blank. Choose other legends (such as circle, square, triangle or line) to plot data correctly. These glitches appear endemic to Vista and do not occur in versions of Windows older or newer than Vista.

The software in-program documentation has been upgraded to compressed HTML (.chm) files, which provide comprehensive context-sensitive help via the Shift+F1 keyboard shortcut and in dialog boxes. Legacy documentation is also available in Microsoft's old WinHelp (.hlp) file format, and the program can switch dynamically between .chm and .hlp files when the latter are available. This is particularly useful when using newer software versions with older instrument models. However, our old WinHelp files may be out of date, and their use is discouraged. Moreover, starting with Windows Vista, Microsoft has also dropped out-of-the-box support for 32-bit .hlp files (although strangely, 16-bit .hlp files from the Windows 3.x era are still supported). This issue can be resolved by installing WinHlp32.exe from the Microsoft website; refer to article KB917607 for more information.

To install the software, insert the software CD. Double-click the "set####.exe" file on the CD to extract the files to your hard drive. The default extraction directory is C:\CHI. The installation simply copies all files to the extraction directory. After installation, you should find chi####.exe (the program executable), chi####.chm (HTML help file), and some test data files (*.bin) in this directory. Administrative rights are not required to run the program, and UAC permissions introduced in Vista should not be an issue. If the executable is copied or moved (say, to D:\My.Prog.exe) it must be accompanied by a help file with the same name (say, D:\My.Prog.chm) for the comprehensive context-sensitive help to be available.

The program has been designed with ease of use in mind. It is self-contained and portable.

Double-click chi####.exe to start the program. The only file required to run the software and control the instrument is chi####.exe, which can be placed in any directory for which you have write and execute permission. This can be particularly useful in restricted user settings (teaching labs, portable installations on removable media, etc.)--simply copy the .exe file and .chm file to, say, the user's home directory.

The first time it is run, the program will automatically generate a binary configuration file (chi####.cfg) containing (virtually) all user preferences and settings. This configuration file will have the same name and location as the executable, and multiple instruments can be controlled using multiple copies of the executable, each with its own configuration file (e.g., chi660d1.exe + chi660d1.cfg and chi660d2.exe + chi660d2.cfg). Newer versions of the software will also generate chi####.ini, which harkens back to a kinder, gentler time when ini files ruled the electronic earth, untrammled by the unreliable tyranny of

the registry. Even now, our software avoids the registry completely, storing all settings in the .cfg and .ini files, streamlining the transfer of user settings between directories or computers to a simple file copy operation.

In previous versions of the software, the auto-generated configuration files would be stored in the C:\CHI directory, and if this directory was not found, the configuration files would be annoyingly spread everywhere. This behavior should not occur in the current software version, and it should be safe to extract the program to any directory on any drive or partition for which you have write and execute permission.

To uninstall the software, simply delete all program files: the executable (.exe), help (.chm and .hlp if present), and configuration (.cfg and .ini). Since no settings are stored on the registry, an uninstaller is unnecessary.

The software CD also contains a hyperlinked, electronic copy of this User Manual and the USB Driver.

Hardware

System hardware installation is also easy and simple. **After unpacking the instrument, you should check your power lines. The AC voltage of the instrument was preset in the factory and is indicated in the serial number label on the back panel.** If the AC voltage is correct, connect the instrument to the power with the power cord.

The instrument communicates with the PC through a USB port (default) or RS-232 serial port (but not both). To use a USB port for data communication, you must first install the USB driver (included on the software CD; also available from www.chinstruments.com). If your computer has a free serial port (9-pin male connector), it can directly communicate with the instrument without installing any drivers using a 9F-25M serial cable (not included).

First, select serial or USB communication using the sliding switch on the rear panel indicated by the arrow in the picture below. The left position is for USB and the right position is for serial port communication. You can use a flat screwdriver to slide the switch.

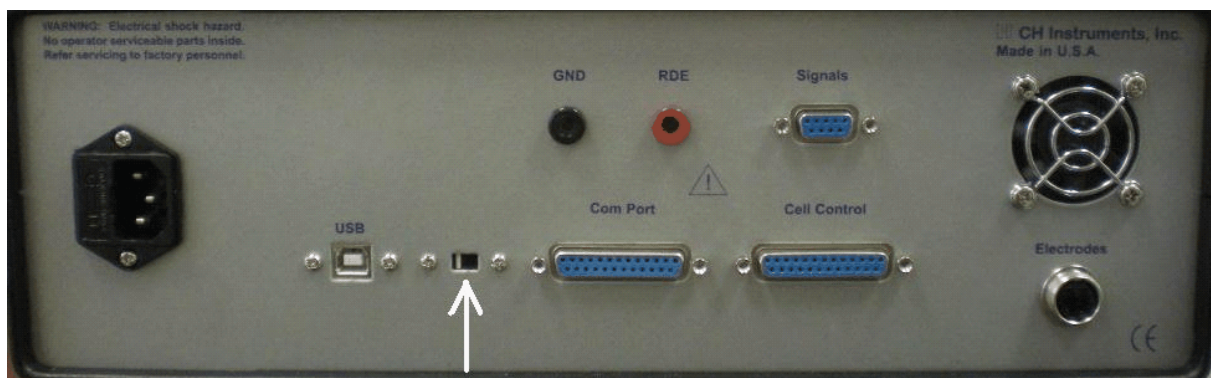

Serial port or USB port switch selection by means of the sliding switch on the rear Panel indicated by the arrow. The setting shown above is for USB (default).

To use a USB port for data communication, you must first install the USB driver (included on the software CD. The USB driver comes with the software CD-ROM. Or you can download it from our website <www.chinstruments.com>. Downloading the driver from the USB chip manufacturer's website is not recommended, as their driver has suffered regressions in the past, and certain newer versions have been known to fail when used with our instrument. The versions available on our website have been thoroughly tested to work properly with our instruments.

To enable USB communication, please use the following procedure:

1. Connect the instrument to the computer using the included USB cable and turn the instrument on.
2. Install the USB driver (included on the software CD). You may need to install more than once. Follow all prompts carefully (find further instructions at the end of this chapter).
3. Open Device Manager (right-click on [My] Computer on the Desktop or Start Menu and click Properties; then click Hardware [if applicable] and Device Manager). Double-click on the category "Ports (COM & LPT)" and see what is listed. You should see a device named "CP2101 USB-Serial bridge" with a corresponding port number (e.g., COM4). If no such device is listed, the driver was not installed properly. Repeat step 2 until you can see the device.
4. Start the instrument program. Using the System command under the program Setup menu, assign the COM port number found in Step 3 and click OK.
5. You are now ready to use the instrument. You may want to try Hardware Test under the Setup menu first.

Note that to use USB communication, you need to turn the instrument on before you start the program. USB is not a resident device. If you do not turn the instrument on first, the program will not see the USB or register the port, and it will issue a "Link Failed" message.

USB communication is achieved using a USB-to-serial chip built into the instrument, allowing serial communication to occur through the USB port using drivers provided by the chip vendor. It therefore provides no specific advantages over the serial port besides the difference in physical connectivity.

To use the serial port for communication, connect the Com Port 25-pin connector on the rear panel to the serial port of your PC using a 9F-25M serial cable (available online, e.g., www.newegg.com or www.monoprice.com). You need to check the settings of the serial port you use. Open Device Manager (right-click on [My] Computer on the Desktop or Start Menu and click Properties; then click Hardware [if applicable] and Device Manager). Double-click on the category "Ports (COM & LPT)" and see what serial (COM) ports are available on your PC.

Use the System command under the program Setup menu to assign the COM port number to match what is listed in Device Manager.

If you consistently encounter "Link Failed" messages, try a different PC. The instrument we delivered was turned on for a week and tested. In nearly all cases, consistent "Link Failed" messages are caused by the PC, either by port settings or problems.

You may occasionally notice unreliable data communication. This could be due to background tasks that generate interrupts, since serial port data communication is interrupt-based. In recent versions, Microsoft Windows has lowered the priority of the serial port interrupt. Other devices, such as disk access, screen saver, virus scan, internet connection, etc. will all generate interrupts that could interfere with the serial port data communication. Please disable your screen saver, disconnect from the internet, disable any virus scanners, and try again.

You should also not use a network card, which will generate a background interrupt that interferes with data transfer between the PC and the instrument. Disconnect the connector to the network card.

If you continue to encounter get "Link Failed" messages after all these efforts, please try a different computer.

Once the instrument and PC can communicate properly, you can connect the electrode leads to the rear panel. The green clip is for the working electrode, white is for reference, and red is for counter. The black clip is a sensing electrode. Please refer to the Appendix of this User Manual for a description of 4-electrode configuration and sensing electrode usage.

The Cell Control port on the rear panel can be used to control purge, stir, and mercury drop dislodge. It can also be used to control external adapters, such as the CHI200B Picoamp Booster, CHI680 Amp Booster, CHI684 Multiplexer, etc. Please refer to the Appendix for more information.

Select models of this instrument are also capable of controlling a Pine Instrument AFMSRX or AFMSREC Rotator for RDE. Two banana jacks on the rear panel will provide a voltage of 0 - 10 V, corresponding to a rotation rate of 0 - 10,000 rpm.

You are now ready to use the instrument.

2.2 USB Driver Installation

Part 1: Driver Installation

System Requirements

- Windows XP / Vista / 7 / 8
- CH Instruments Software version 12.04 or newer

If your system does not meet the requirements above, please visit our website for instructions and downloads for all versions of Windows, starting from Windows 98.

Installation Procedure

1. Do not connect the instrument to the computer yet.
2. Double-click the USB Driver installer on your software CD.
3. Follow the on-screen instructions, accepting all default options in the affirmative.
 - Make sure the "Launch the CP210x VCP Driver Installer" option is checked, when it appears.
 - This should install files in two locations.
 - Restart your computer if prompted to do so.
4. Finally, power on and connect your instrument to your computer. Windows should now recognize the instrument automatically.
5. Please note that the latest driver requires our software version 12.04 or newer.

Part 2: Instrument Installation

Installation Procedure

1. Complete the USB Driver Installation Procedure from Part 1 above.
2. Disconnect the instrument from your PC, if applicable.
3. Connect the instrument to your PC and turn the power on.
4. Wait for any automatic system installation tasks to complete.
5. Open Device Manager (right-click [My] Computer > Manage > Device Manager).
6. Double-click the category "Ports (COM & LPT)" to display:

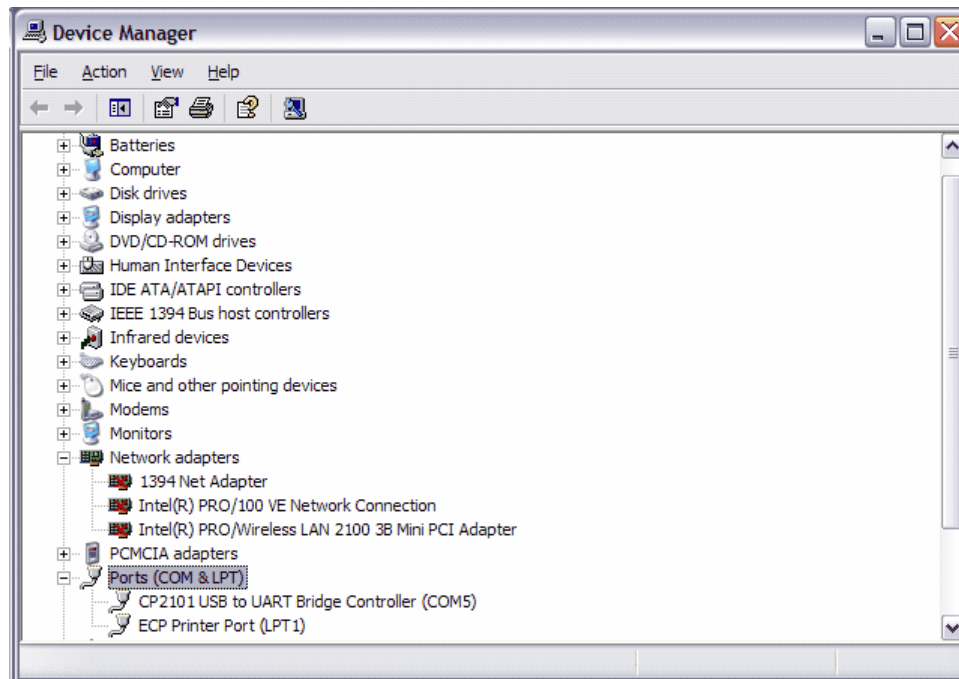

7. Determine the COM number for the newly installed "CP2101 USB to UART Bridge Controller" or similarly named device.
 - In the figure above, this is COM5.
8. Assign this COM number using the System command under the Setup menu in our software.
9. Run the Hardware Test command under the Setup menu to confirm that the instrument and computer are communicating properly.

This completes instrument installation.

Part 3: Additional Information

In the future, if you encounter the "Can not open com port" message when starting the program, please check Device Manager again and see what com port number is currently assigned to the instrument. If the com port number assignment has changed, you need to set the com port number using the System command accordingly. If you do not see the CP2101 device listed in under Ports (COM & LPT), please make sure your instrument is turned on and the USB cable is properly connected.

The USB driver needs to be installed only once on your computer. Multiple instruments can be connected to the same computer, and Windows automatically assign them to different COM ports.

USB communication is achieved using a USB-serial port converter chip inside the instrument. Our software will behave as if this device is connected to a serial port, even though the physical connection is by USB. Thus, you need to use Device Manager as described above to determine what serial port number is assigned to this device.

You can double-click on the "CP210x USB to UART Bridge Controller" item in Device Manager to display various status information: driver version number, whether the driver is functioning correctly, etc.

If you have a free serial port available on your PC, we recommend its use over a USB port. This is because we implement USB connectivity using a USB-to-serial chip on the instrument, allowing serial communication to occur through the USB port using drivers provided by the chip vendor. USB

therefore provides no specific advantages over the serial port besides the difference in physical connectivity, and both the instrument and the PC will interact as if connected by a serial connection. The reason we include USB support is that most computers sold today do not include a serial port, and it may be impractical or even impossible to add a serial port card.

However, the supplied third-party USB-serial port drivers may not be perfect. We have tested them on several computers in our office and they all seem to work, but if problems occur, since the Windows drivers are closed-source, we have no way to modify, let alone debug them. Our only recourse in that scenario would be to file a support ticket with the chip vendor, and it may prove more expedient to buy a USB to Serial Adapter cable and a DB-25 male to DB-9 female cable (each ~\$10 USD at the time of this writing).

For more information, please visit <www.chinstruments.com/downloads.shtml>.

2.3 Testing

The instrument was thoroughly tested by our quality assurance team before it was shipped. The "*.bin" files included on the software CD are the data actually acquired with the particular instrument you received.

To test communication between the computer and the instrument, start the software and turn the instrument on. Use the Hardware Test command under the Setup menu. If a "Link Failed" error appears, should check the connection and port settings. Use the System command under the program Setup menu to see if the port setting matches the port in use.

If hardware test results appear on the screen, the PC-instrument communication is working properly. The hardware test results will provide further details regarding the status of your instrument.

To test hardware performance, you can use (say) a 100K ohm resistor as a dummy cell. Short the reference (white) and counter (red) electrode leads and connect the 100K ohm resistor between the red/white clips and working (green) electrode clip. Select the potential range to be 0.5 V to -0.5 V using the Parameters command under the Setup menu. The sensitivity can be set to 1e-6 A/V. Run the experiment using the Run command under the Control menu. You should observe a straight line with current from -5e-6 A to +5e-6 A.

To test software performance, open a data file using the Open command under the File menu to open the test data files included on the software CD. ***These are the actual test results for this particular instrument.*** To open the files, select the files and click OK, or double-click the filename. After reading them in, you can display or process the data. Try the commands under the Graphics and DataProc menus. To revert to the original data and undo all unsaved changes, simply close the file and reload the data with the Open command.

2.4 Some Useful Tips

If you are comfortable with Windows applications, you may not have any problem using the instrument. Most of the following tips are intended for users who do not have much experience with Windows, but may still be useful even for experienced users.

1. Familiarize yourself with the toolbar (the bar with many buttons under the main menu bar), which provides quick access to the most commonly used commands. Hover the mouse cursor over a button without clicking to display a descriptive comment in the lower-left corner of the main window.
2. To select multiple filenames for multiple file printing, overlay plots, parallel plots, etc., left-click on the name of the first file you want to select and drag the mouse while holding the left button to select multiple files. If the files you want are scattered in the directory (i.e., non-consecutive), you can select them by holding down the Ctrl key and clicking on each filename.
3. If the Y axis title is oriented in the wrong direction, use the Font command under the Graphics menu to change the rotation angle of the Y axis for printing.
4. To select a file or technique, you can double-click the item. This is equivalent to clicking the item and then click OK.
5. To change parameters in a dialog box, you can use the Tab key to cycle through its fields. Text in the edit box will become highlighted, and you can type directly to replace the highlighted text. This can sometimes be much more convenient and faster than using the mouse. Advanced users should also consider memorizing frequently used keyboard shortcuts (press the Alt key to move focus to the menu bar, then type underlined letters to enter menus and run commands).
6. The internal noise of the instrument is quite low. The most common and most serious source of noise is the line frequency (60 Hz or 50 Hz). The instrument contains analog low-pass filters to reduce this noise. At a scan rate of 0.1 V/s, the automatic filter cutoff setting is 150 or 320 Hz, which does not cover the line frequency, but at a scan rate of 0.05 V/s, the cutoff frequency of the filter is 15 or 32 Hz, and the line frequency noise can be effectively reduced. Line frequency noise can also be reduced if the sampling interval is set to a multiple of the period of the power line. For small signals or relatively fast experiments, use of a Faraday cage is strongly recommended.
7. Use the Graph Options command under the Graphics menu to adjust the way data is displayed; see Chapter 6 for more information on the wide variety of options available.

Chapter 3 File Menu

The **File** menu offers the following commands:

New	Creates a new document.
Open	Opens an existing document or text file.
Close	Closes an opened document.
Save As	Save current document; can convert to plain text, csv.
Delete	Delete existing data files permanently (legacy command).
Retrieve	Retrieve lost experimental data.
Update Instrument Prog.	Update instrument firmware.
List Data File	Display an existing data file in text format.
Convert to Text	Convert multiple existing data files to text files.
Text File Format	Choose text file formatting options.
Import Text File	Import text file (legacy command superseded by Open).
Print	Prints a document.
Print Multiple Files	Print multiple documents.
Print Preview	Displays the document on the screen as it would appear printed.
Print Setup	Selects a printer and printer connection.
Send...	Sends the active document through electronic mail.
Most Recently Used	Open the most recently used documents quickly.
Exit	Exits the program.

3.1 Open command

This command opens the File Open dialog box.

Use this command to open one or more existing documents each in a new window. You can open multiple documents at once. The program displays the File Open dialog box so you can select the files you want to convert.

Binary data files and text files saved from the program can both be read directly by this command, which fully supersedes the Import Text File command.

When a file is read, the program places its data in memory and updates the display, technique, and experimental parameters (some of which are only available in binary data files). You can only open files generated by this or an older version of the software.

Use the **Window** menu to switch among the multiple open documents. See Window 1, 2, ... command . You can create new blank documents with the New command.

This command has a toolbar button:



The Open command presents this dialog box.

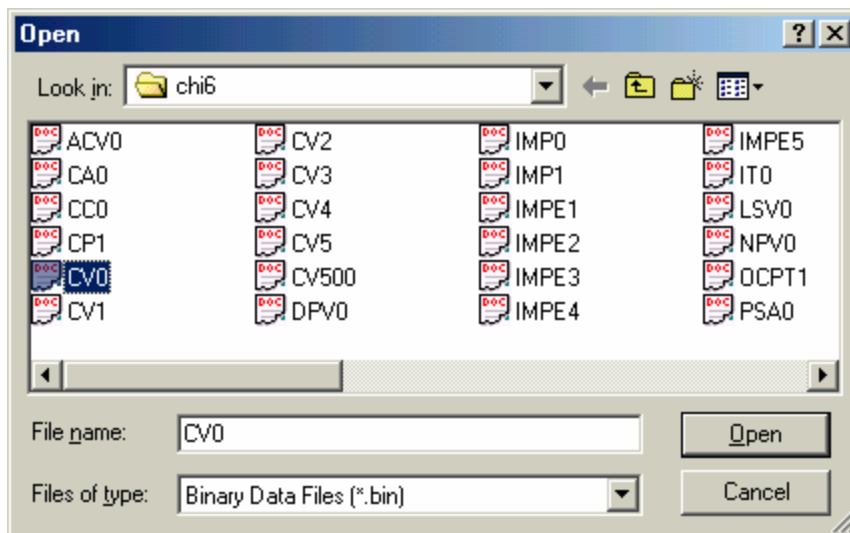

Binary data files and text files saved from the program can both be read directly by the Open command, which fully supersedes the Import Text File command.

The following options allow you to specify which file to open:

File name

Type or select the name of the file(s) to be opened. The box above lists files with the extension you select in the "Files of type" box. You don't have to type the extension; the program will automatically attach the selected extension in the "Files of type" box to the filename (or the default ".bin" if All Files (*.*) is selected). Multiple file names in the "File name" field are enclosed by quotation marks and separated by spaces, for example, "CV0" "CV1".

Files of type

Specifies the type of file you want to open (by default, all files are displayed):

Extension	Description
.bin	Binary data files
.txt	Plain text files
.csv	Comma-separated value files

3.2 Save As command

This command opens the File Save As dialog box.

Use this command to save and name the active document. The program displays the Save As dialog box so you can name your document.

When a non-binary file type is selected, this command allows you to perform the Convert to Text operation on the currently active data file without having to navigate to the file.

This command has a toolbar button:



The Save As command presents this dialog box.

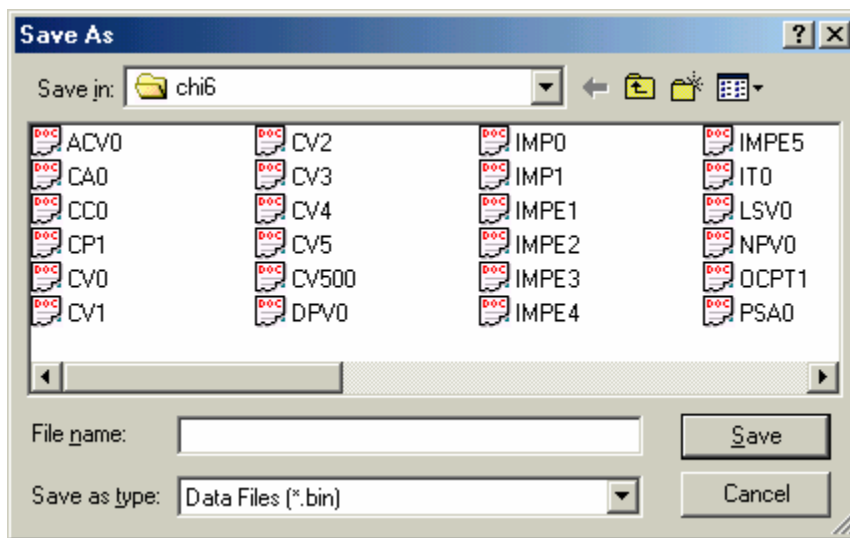

The following options allow you to specify the name and location of the file you're about to save:

File name

Specifies a file name to save the current data and system variables with a different name. You don't have to type the extension; the program will automatically add the extension you specify in the "Save as type" box. If an existing filename is used, the system will display a confirmation prompt before proceeding.

Save as type

Specifies the type of file you want to save as. When saving in the ".txt" or ".csv" formats, a corresponding ".bin" file will be generated unless a binary file is currently open. The use of binary files is encouraged, since they contain many system parameters that are not stored in other formats.

Extension Description

.bin	Binary data files (recommended)
.txt	Plain text files (compatible with most other programs)
.csv	Comma-separated value files (useful for spreadsheet programs)

For a macro file, the extension is ".mcr". For a simulation file, the extension is ".sim". Other extensions are not allowed.

3.3 Delete command

Use this deprecated command to delete files permanently via the File Delete dialog box.

The Delete command bypasses the Recycle Bin that has been available starting with Windows 95, and its use is discouraged for all but the audacious and the accustomed.

To send one or more files to the Recycle Bin (unless it has been disabled in your Windows system settings), in the CHI program environment, select the desired file(s) in the, say, Open or Save As dialog box and press the Del key. Windows will then prompt you for confirmation to send the file(s) to the Recycle Bin. To delete files permanently in the same manner, press Shift+Del instead of Del.

The deprecated Delete command presents this dialog box.

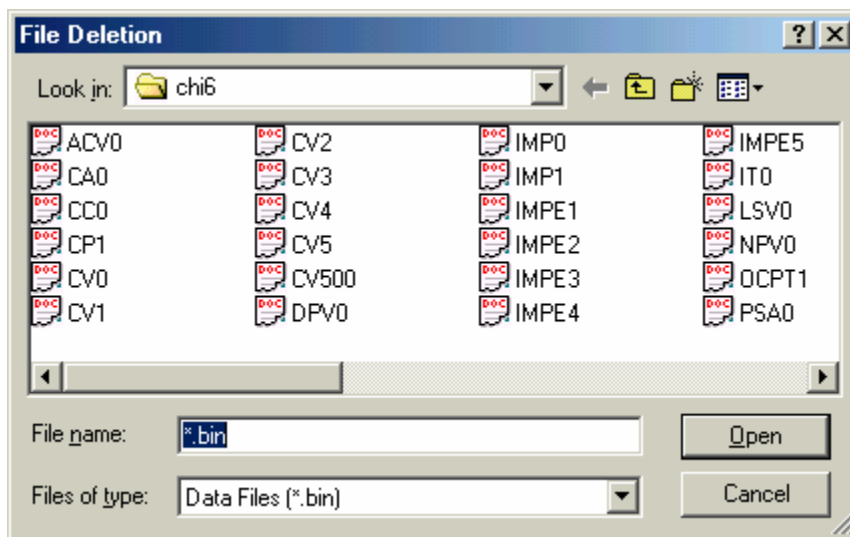

The following options allow you to specify the name and location of the file you're about to delete permanently:

File name

Type or select the filename(s) you want to delete permanently. You don't have to type the extension; the system will automatically attach the selected extension in the "Files of type" box to the filename. The box above lists files with the extension you select in the "Files of type" box. To delete multiple files permanently, point the mouse cursor to the files you want to select and click the left mouse button while holding down the Ctrl key.

You will be prompted for confirmation before the files are deleted permanently.

Files of type

Select the type of file you want to delete permanently.

3.4 Retrieve command

Use this command to retrieve data saved on the PC hard drive during an experimental run. In case your experiment does not run to completion, e.g., due to external interference, interruption, or missed communication, data can be recovered partially. This is useful for very slow experiments; hours of experimental data can be recovered.

For performance reasons, this command is not enabled by default. For fast experiments, it may prove more expedient to simply re-run the experiment instead of using the Retrieve command. In order to enable the Retrieve command, use the System command under the Setup menu and check the "Save retrieve data during run" option.

Data from the previous run must be retrieved before starting a new run. Once a new run has started, the saved data for the last run will be lost and cannot be recovered.

3.5 Update Instrument Program command

This command opens the Firmware Update dialog box.

Control of the instrument control is accomplished by two interacting components: the software that resides on the PC, and the firmware that resides on the instrument. This command, available in all of our newer models with flash memory, allows the user to install firmware updates, which are issued occasionally by CH Instruments, Inc.. For more information about software and firmware updates, please consult the Appendix of this User Manual or contact info@chinstruments.com.

3.6 List Data File command

This command opens the List Data File dialog box.

Use this command to display a saved data file in text mode. Formatting options are available in the Text File Format command.

The current data remains unchanged when this command is executed. To view the current data similarly, use the Data Listing command under View menu.

The List Data File command presents this dialog box.

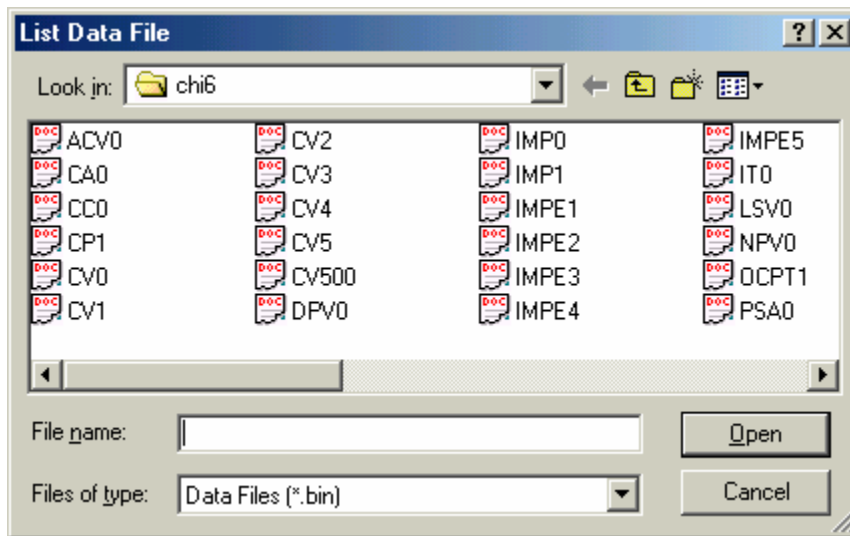

The following options allow you to specify the name and location of the file you're about to display in text mode:

File name

Type or select the filename you want to display. The box above lists files with the extension you select in the "Files of type" box.

You don't have to type the extension. The system will automatically attach an extension of ".bin" to the filename. Other extensions are not allowed.

Files of type

Select the type of file you want to list. Only ".bin" files (binary data) are available.

3.7 Convert to Text command

This command opens the File Conversion dialog box.

Use this command to convert one or more binary data files to text (the format can be altered with the Text File Format command in the File menu). The program displays the File Conversion dialog box so you can select the files you want to convert.

The resulting text file can be read by other software, such as commercial spreadsheet or database handlers.

The Convert to Text command presents this dialog box.

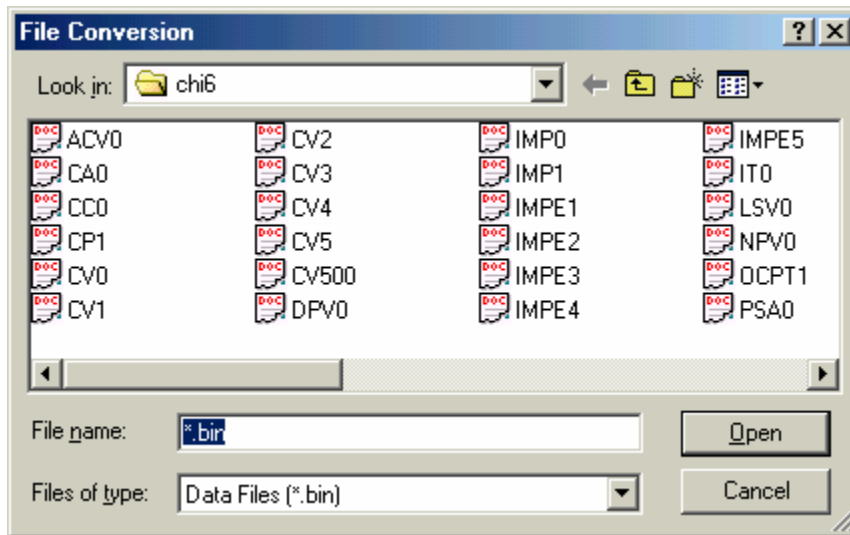

To select multiple files for conversion, point the mouse cursor to the filenames you want to select and click the left mouse button while holding the Ctrl key, or left-click on two files while holding the Shift key to select a range of files, or left-click and drag. To quickly convert the currently active file, use the Save As command instead.

The following options allow you to specify the name and location of the binary file(s) that will be converted to text format:

File name

Type or select the filename(s) you want to convert. The box above lists files with the extension you select in the "Files of type" box.

Multiple files can be selected for conversion.

You don't have to type the extension. The program will automatically attach an extension of ".bin" to the filename. Other extensions are not allowed.

Files of type

Select the type of file you want to convert. Only the ".bin" type (binary data file) will be available.

3.8 Text File Format command

This command opens the Text File Format dialog box.

Use this command to specify text formatting options for non-binary files generated by the Save As and File Conversion commands.

The Text File Format command presents this dialog box.

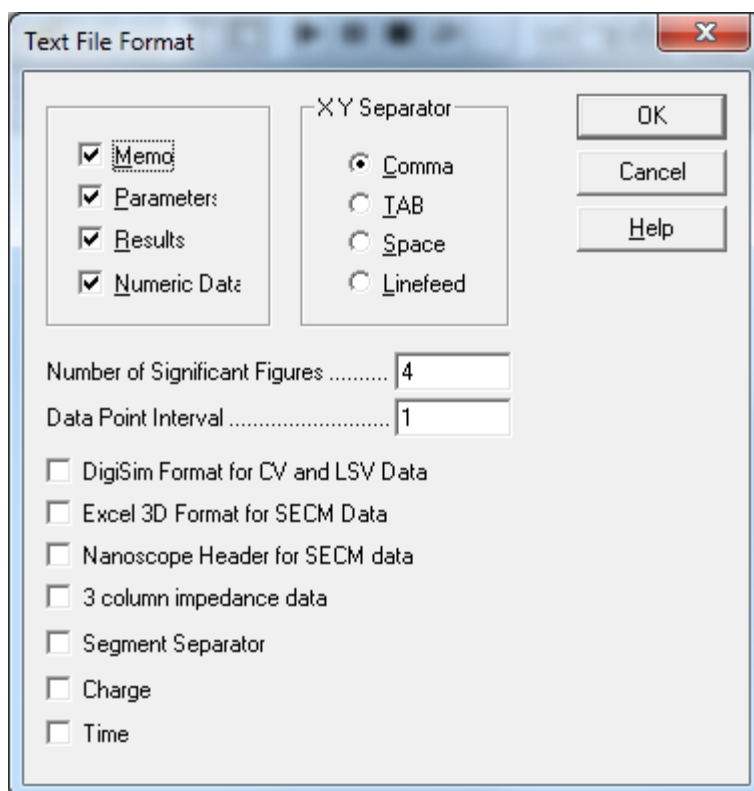

Memo

Check this box to include date, time, technique name, labels, and notes in the output text file.

Parameters

Check this box to include experimental parameters in the output text file.

Results

Check this box to include experimental results such as peak/wave potential, current, and electrode area in the output text file. To select the item to be displayed on screen when an experiment is complete, execute the Peak Definition command in the Graphics menu.

Numeric Data

Check this box to include numeric data points in the output text file.

Separator

Select the separator (comma, TAB, space, or linefeed) to be used between data columns. For two data points X and Y, the resulting output will be:

Separator	Output
Comma	X, Y
TAB	X Y
Space	X Y
Linefeed	X Y

This allows you to make the data format compatible with other commercial software, such as spreadsheet or database handlers.

Number of Significant Figures

This option allows you to set the data precision of the text file up to a maximum of 10 significant digits (figures). A larger number of significant digits will of course result in larger data files. The default setting of 4 significant digits is sufficiently precise for most applications.

Data Point Interval

This option allows you to store or display a subset of the data points. For example, when the value is changed to 3, only every 3rd data point will be stored or displayed. This option is useful for quick examination of data or file size reduction. However, some details might be lost.

DigiSim Format for CV and LSV Data

This option applies only to CV and LSV data. When this box is checked, the text data file will be directly readable by DigiSim (© Bioanalytical Systems, West Lafayette, IN) software.

Excel 3D Format

This option applies only to SECM image data (CHI 900 series). When this box is checked, the output text data file can be read directly by Excel (© Microsoft Corp., Redmond, WA) to generate a 3D surface plot.

To generate Excel 3D surface plots, follow these instructions:

1. Start the Excel Program.
2. Open the target text data file created by the CHI900/CHI900A/CHI900B program.
3. The "Text Import Wizard - Step 1 of 3" dialog box will appear. Click "Next".
4. The "Text Import Wizard - Step 2 of 3" dialog box will appear. Change the Delimiters setting to match the data separator used in the output text file. Click "Finish". A spreadsheet containing the data will appear.
5. Select all data points in the spreadsheet.
6. Click the "Chart" command in the "Insert" menu.
7. The "ChartWizard - Step 1 of 4" dialog box will appear. Choose "Surface" and click "Next".
8. The "ChartWizard - Step 2 of 4" dialog box will appear. Choose "Rows" and click "Next".
9. The "ChartWizard - Step 3 of 4" dialog box will appear. Enter descriptive labels and change graph options as desired. Click "Finish" when done.
10. A 3D surface plot will appear in the spreadsheet data area. You can resize the plot by left-clicking and dragging on the edges of the plot.
11. Copy and paste the graph into a word processor for further usage or printing. Exporting the graph to a picture format like JPEG or PNG (e.g., by pasting in Paint) and inserting the resulting picture into a word processor document will generally reduce the final file's size, but will also lower the resolution of the plot.

If the data density is so high that the lines between data points cannot be seen clearly, set the data point interval to more than 1 as described above.

Nanoscope Header

This option applies only to SECM image data (CHI 900 series). When this box is checked, the output text data file will be directly readable by Nanoscope (© Veeco Instruments Inc., Santa Barbara, CA) software to create a 3D image. However, as Veeco Instruments frequently updates their Nanoscope software, your generated text file may not be readable if your version of Nanoscope is older than the CHI 900B series software.

3.9 Import Text File command

This deprecated command opens the Import Text File dialog box.

Use the Import Text File command to import text files; CHI and BAS text file formats are both supported.

For CHI text files, this command will only succeed if Memo and Parameter fields are present.

For BAS text files, parameters will be converted to be CHI format.

This command can only import one text file at a time; to import multiple files, use the Open command instead.

The Import Text File command presents this dialog box.

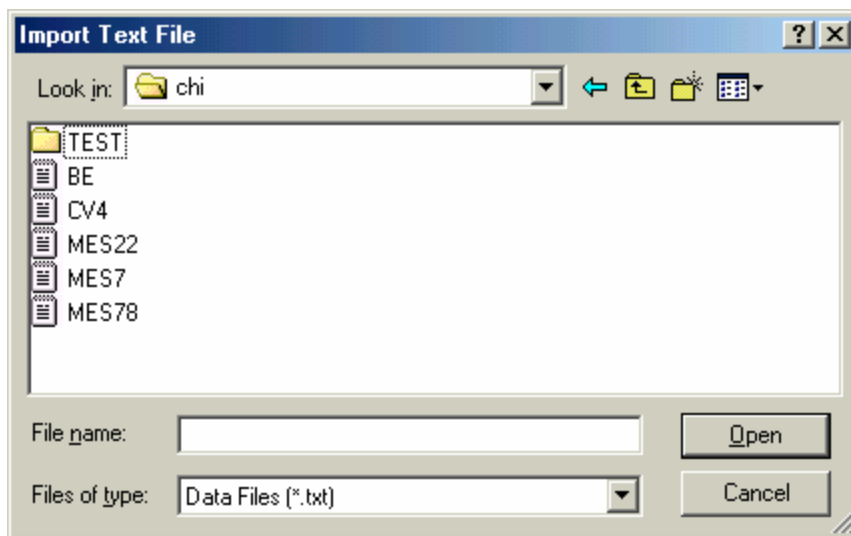

3.10 Print command

Use this command to print a document.

The printer output is identical to what is displayed on the screen (What You See Is What You Get). Use the Graph Option command in the Graphics menu to customize the print output.

The paper orientation must be set to landscape. If a warning pops up, use the Print Setup command to set the paper orientation to landscape.

This command has a toolbar button:



3.11 Print Multiple Files command

This command opens the Multiple File Print dialog box. Printer output is identical to what is displayed on the screen (What You See Is What You Get). Use the Graph Option command under the Graphics menu to customize the print output.

Use this command to print multiple data files.

The Print Multiple Files command presents this dialog box.

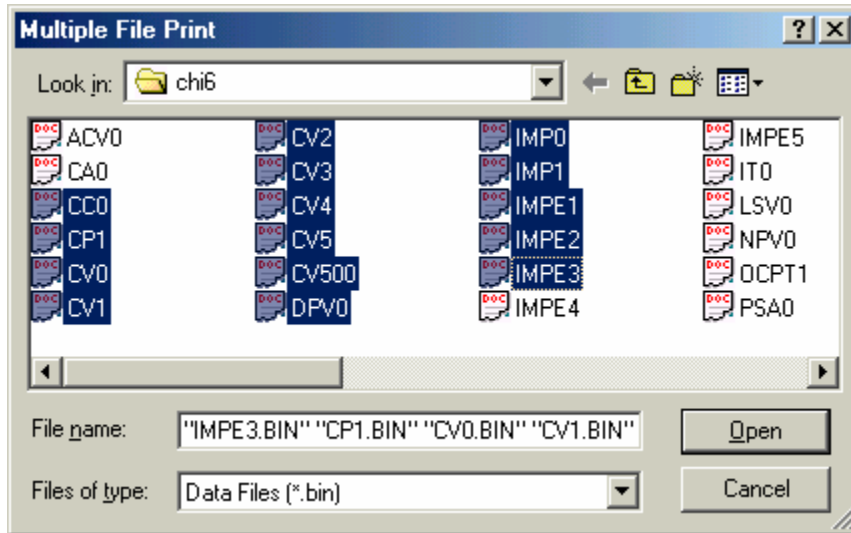

The following options allow you to specify the name and location of the binary data files you're about to print:

File name

Type or select the filename(s) you want to print. The box above lists files with the extension you select in the "Files of type" box. To select multiple files, hold down the Ctrl key and left-click on the desired files.

You don't have to type the extension, the system will automatically attach a ".bin" extension to the filename. Other extensions are not allowed.

Files of type

Select the type of file you want to print. Only ".bin" files (binary data) are available.

3.12 Print Setup command

This command opens the Print Setup dialog box. Use this command to select a printer and a printer connection. This command presents a Print Setup dialog box, where you specify the printer and its connection.

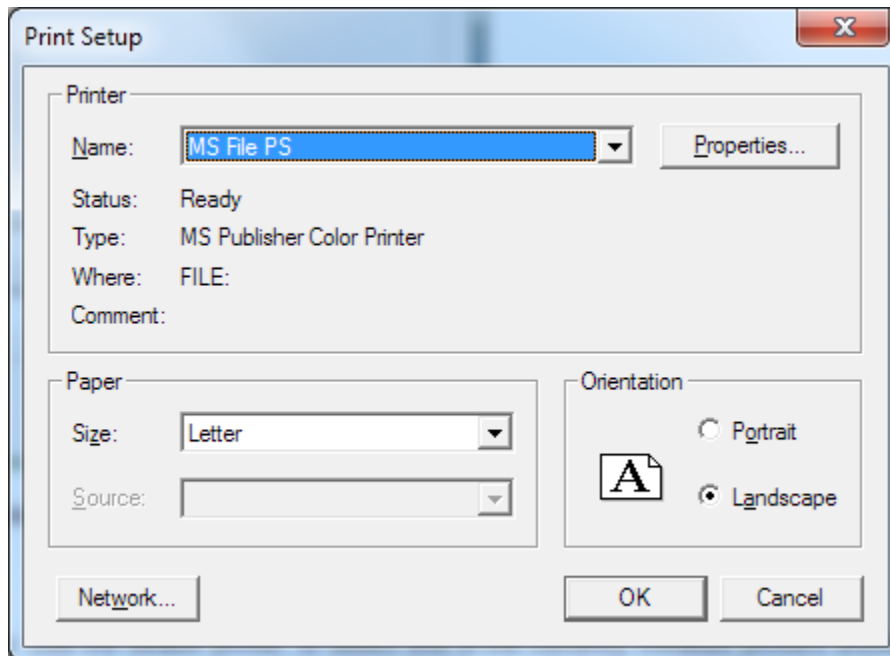

Printer Name

Specifies the printer you want to use. Use the default printer, or select one of the currently installed printers shown in the box. You can install printers and configure ports using the Windows Control Panel.

Printer Properties

Displays a dialog box where you can make additional choices about printing, specific to the type of printer you have selected.

Orientation

Specifies Portrait or Landscape. The paper orientation should be set to landscape in the CHI program environment. If you choose Portrait and try to print, a warning may pop up, and you will have to use the Print Setup command to set the paper orientation back to landscape.

Paper Size

Specifies the size of paper that the document is to be printed on.

Paper Source

Specifies the paper source, because some printers offer multiple trays for different paper sources.

Network

Click this button to connect to a network location, assigning it a new drive letter.

3.13 Exit command

Use this command to end your program session. The program prompts you to save documents with unsaved changes. Upon exiting, settings including directory, system setup, control status, macros, data processing, simulation, and graphics options, color, and font will be saved.

Chapter 4 Setup Menu

The **Setup** menu offers the following commands:

Technique	Select one of many electrochemical techniques.
Parameters	Choose experimental parameters.
System	Set system defaults.
Hardware Test	Test system hardware.

4.1 Technique command

This command opens the Electrochemical Techniques dialog box.

Use this command to select an electrochemical technique. This frequently used command is the fountainhead from whence all experiments spring forth.

This command has a toolbar button:



The Technique command presents this dialog box, which lists all electrochemical techniques available on your instrument.

Technique Selection

Double-click the desired technique, or single-click, adjust the Polarographic Mode option, and then click OK.

Polarographic Mode

Check this box to enable polarographic mode, allowing the mercury drop to grow and be dislodged for every data point.

Polarographic mode is available only for the following techniques:

- Staircase Polarography (SCP)
- Differential Pulse Polarography (DPP)
- Normal Pulse Polarography (NPP)
- Differential Normal Pulse Polarography (DNPP)
- A.C. Polarography (ACP)
- Second Harmonic A.C. Polarography (SHACP)

Enabling polarographic mode will automatically disable stripping mode. To re-enable stripping mode, the Polarographic Mode option must be unchecked.

4.2 Parameters command

This command opens a dialog box to set experimental parameters for the technique currently selected in the Electrochemical Techniques dialog box.

This command has a toolbar button:



The following parameter dialog boxes available for your instrument series are listed below. For details about each technique, please refer to the description of each dialog box.

- Parameters for Cyclic Voltammetry
- Parameters for Linear Sweep Voltammetry
- Parameters for Staircase Voltammetry
- Parameters for Tafel Plot
- Parameters for Chronoamperometry
- Parameters for Chronocoulometry
- Parameters for Differential Pulse Voltammetry
- Parameters for Normal Pulse Voltammetry
- Parameters for Differential Normal Pulse Voltammetry
- Parameters for Square Wave Voltammetry
- Parameters for A.C. Voltammetry
- Parameters for 2nd Harmonic A.C. Voltammetry
- Parameters for FT A.C. Voltammetry
- Parameters for Amperometric i-t Curve
- Parameters for Differential Pulse Amperometry
- Parameters for Double Differential Pulse Amperometry
- Parameters for Triple Pulse Amperometry
- Parameters for Integrated Pulse Amperometric Detection
- Parameters for Bulk Electrolysis with Coulometry
- Parameters for Hydrodynamic Modulation Voltammetry
- Parameters for Sweep-Step Functions
- Parameters for Multi-Potential Steps
- Parameters for A.C. Impedance
- Parameters for Impedance - Time
- Parameters for Impedance - Potential
- Parameters for Chronopotentiometry
- Parameters for Chronopotentiometry with Current Ramp
- Parameters for Multi-Current Steps
- Parameters for Potentiometric Stripping Analysis
- Parameters for Electrochemical Noise Measurement
- Parameters for Open Circuit Potential - Time

4.2.1 Cyclic Voltammetry Parameters dialog box

In Cyclic Voltammetry (CV), the potential is linearly swept from Init E to High E (or Low E, depending on the Init P/N polarity parameter). The potential is then swept back in the reverse direction. The following diagram shows the applied potential waveform as a function of time. Current is recorded as a function of potential.

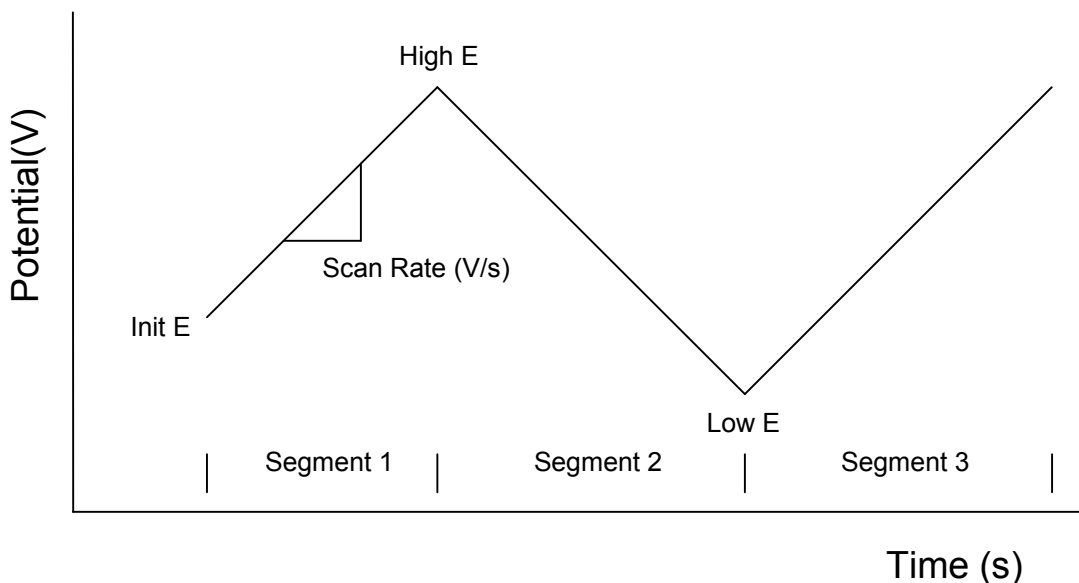

Parameter	Range	Description
Init E (V)	-10 - +10	Initial potential
High E (V)	-10 - +10	Upper limit of potential scan
Low E (V)	-10 - +10	Lower limit of potential scan
Init P/N	Pos. or Neg.	Initial scan direction
Scan Rate (V/s)	1e-6 - 10000	Potential scan rate
Sweep Segments	1 - 1000000	Sweep segments (each is half cycle)
Sample Int. (V)	0.001 - 0.064	Data sampling interval
Quiet Time (sec)	0 - 100000	Quiescent time before potential scan
Sensitivity (A/V)	1e-12 - 0.1	Sensitivity scale
Auto Sens	Check or Uncheck	Automatic sensitivity switching during run
Enable Final E	Check or Uncheck	Allow potential scan to end at Final E
Aux. Signal Rec.	Check or Uncheck	Record external signal

Notes

- The potential increment is 0.1 mV when the scan rate is below 1000 V/s, 1 mV at 5000 V/s, and 2 mV at 10000 V/s.
- High E and Low E should be at least 0.01 V apart.
- If unreasonably values for High E or Low E are entered, the system will automatically readjust them.
- Depending on the Init E, High E, and Low E values, the system will automatically readjust the initial scan direction.
- The maximum potential scan range is 13.1V.
- The sampling interval can be 1 mV when the scan rate is below 1000 V/s, 2 mV below 2000 V/s, 5 mV below 5000 V/s, and 10 mV below 10000 V/s. The data sampling interval will be automatically increased at high scan rates.
- When a large number of sweep segments is involved, the data sampling interval will be automatically increased up to 0.02 V. If the scan rate is higher than 0.5 V/s (or 3 V/s using fast com

port speed), the number of sweep segments will be limited by the instrument memory size (64K points). If the scan rate is lower than 0.5 V/s (or 3 V/s using fast com port speed), the maximum data length specified by the System command will take effect. When the scan rate is low, the specified sweep segments will be executed, but only a limited number of segments will be stored. Large sweep segments can be useful for, say, electrode conditioning.

- When the scan rate is below 0.01 V/s, the sensitivity scale during the run can be automatically adjusted according to the current level. When Auto Sens is enabled, the value of the Sensitivity field will have no effect on the measurement. However, the smallest available automatic sensitivity will be 1e-8 A/V instead of 1e-12 A/V. The Picoamp Booster will not work either. In order to specify smaller sensitivities, the automatic sensitivity switching option must be disabled.
- The Enable Final E option will allow you to scan complete cycles when the number of Sweep Segments is odd and Initial E is different from High E and Low E. Check the Enable Final E box and set Final E equal to Initial E, and the last segment will stop at Initial E instead of High E or Low E.
- It is possible to record external voltage signals (e.g., spectroscopic signals) simultaneously with the voltammogram (maximum scan rate may be limited). Use the 9-pin D-connector on the rear panel for signal input. Consult the User's Manual for the pin-out and signal level requirements.

4.2.2 Linear Sweep Voltammetry Parameters dialog box

In Linear Sweep Voltammetry (LSV), the potential is scanned from Init E toward Final E. The following diagram shows the potential waveform applied as a function of time. Current is recorded as a function of potential.

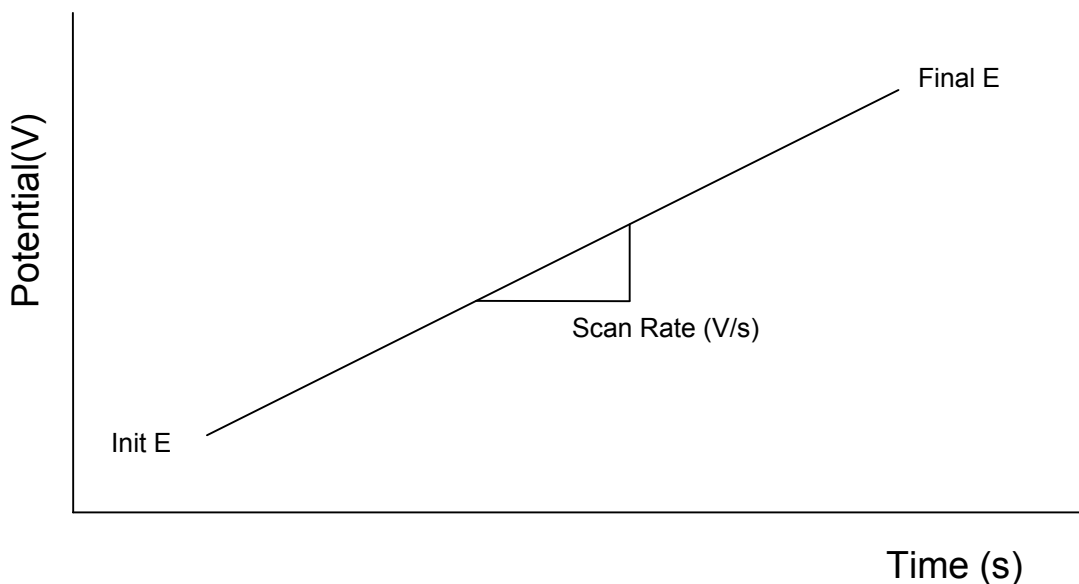

Parameter	Range	Description
Init E (V)	-10 - +10	Initial potential
Final E (V)	-10 - +10	Final potential
Scan Rate (V/s)	1e-6 - 20000	Potential scan rate
Sample Int. (V)	1e-6 - 0.064	Data sampling interval
Quiet Time (sec)	0 - 100000	Quiescent time before potential scan
Sensitivity (A/V)	1e-12 - 0.1	Sensitivity scale
Auto Sens	Check or Uncheck	Automatic sensitivity switching during run if scan rate \leq 0.01 V/s
Aux. Signal Rec.	Check or Uncheck	Record external signal when scan rate $<$ 0.25 V/s

Notes

- Init E and Final E should be at least 0.01 V apart.
- The maximum potential scan range is 13.1 V.
- When the scan rate is high, the data sampling interval will be automatically increased.
- When the scan rate is below 0.01 V/s, the sensitivity scale during the run can be automatically adjusted according to the current level. When Auto Sens is enabled, the value of the Sensitivity field will have no effect on the measurement. However, the smallest available automatic sensitivity will be 1e-8 A/V instead of 1e-12 A/V. The Picoamp Booster will not work either. In order to specify smaller sensitivities, the automatic sensitivity switching option must be disabled.
- Linear polarization resistance plots can be generated using the Special Plots command under the Graphics menu.
- The potential increment is 0.1 mV when the scan rate is below 1000 V/s, 1 mV at 5000 V/s, and 4 mV at 20000 V/s.
- The sampling interval can be 1 mV when the scan rate is below 1000 V/s, 2 mV at 2000 V/s, 5 mV at 5000 V/s, and 20 mV at 20000 V/s. The data sampling interval will be automatically increased at high scan rates.
- If the scan rate is below 0.25 V/s, it is possible to record external voltage signals (e.g., spectroscopic signals) simultaneously with the voltammogram. The input full scale range is +/-10V. Use the 9-pin

D-connector on the rear panel for signal input. Consult the User Manual for the pin-out and signal level requirements.

4.2.3 Staircase Voltammetry Parameters dialog box

In Staircase Voltammetry (SCV), the potential is incremented from Init E toward Final E, and it may be scanned back. The following diagram shows the potential waveform applied as a function of time. Current is sampled after every potential increment and recorded as a function of potential.

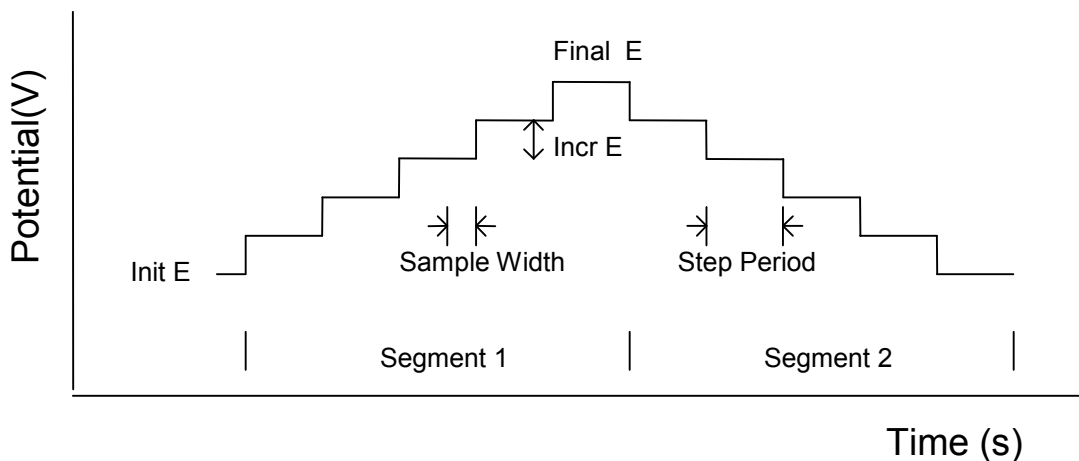

Parameter	Range	Description
Init E (V)	-10 - +10	Initial potential
Final E (V)	-10 - +10	Final potential
Incr E (V)	1e-3 - 0.05	Increment potential of each step
Segments	1 - 1000	Number of scan segments
Sampling Width (s)	1e-4 - 50	Data sampling width for each point
Step Period (s)	0.001 - 50	Potential step period or dropping time
Quiet Time (sec)	0 - 100000	Quiescent time before potential scan
Sensitivity (A/V)	1e-12 - 0.1	Sensitivity scale

Notes

- Init E and Final E should be at least 0.01 V apart.
- Sampling Width should be no more than half of Step Period; otherwise the system will automatically readjust the former.
- Data sampling always occurs at the end of each step.

4.2.4 Tafel Plot Parameters dialog box

In the Tafel Plot technique (TAFEL), the potential is scanned from Init E toward Final E. The potential may be held there and then scanned back. The following diagram shows the potential waveform applied as a function of time. The logarithm of current is recorded as a function of potential.

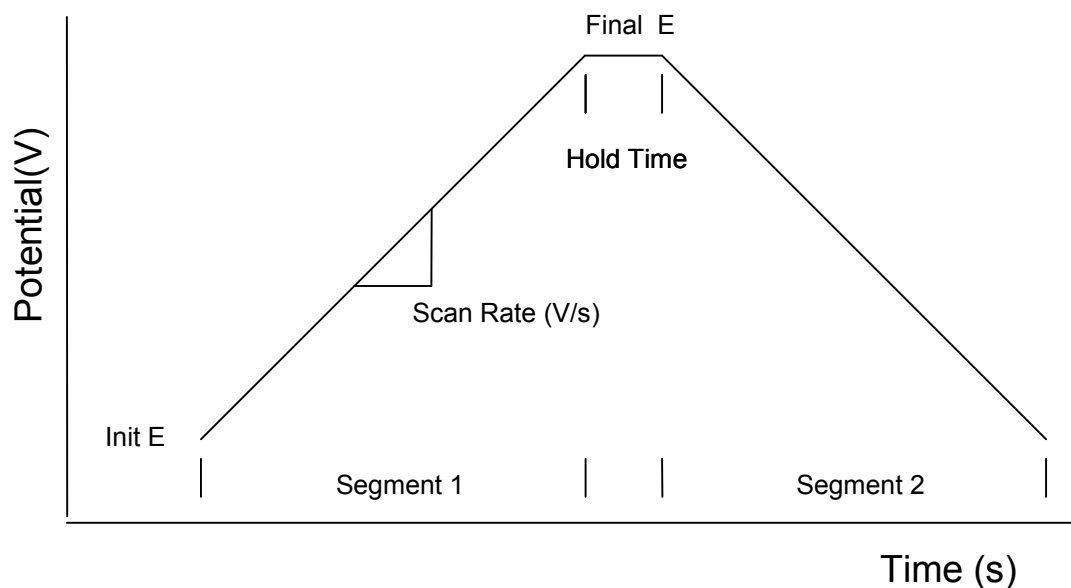

Parameter	Range	Description
Init E (V)	-10 - +10	Initial potential
Final E (V)	-10 - +10	Final potential
Incr E (V)	1e-3 - 0.05	Increment potential of each step
Sweep Segments	1 - 2	Sweep segments; each segment is half cycle
Scan Rate (V/s)	1e-6 - 0.01	Potential scan rate
Quiet Time (sec)	0 - 100000	Quiescent time before potential scan
Sensitivity (A/V)	1e-12 - 0.1	Sensitivity scale
Auto Sens	Check or Uncheck	Automatic sensitivity switching during run

Notes

- Init E and Final E should be at least 0.01 V apart.
- Corrosion rate calculations can be performed using the Special Analysis command under the Analysis menu.

4.2.5 Chronoamperometry Parameters dialog box

In Chronoamperometry (CA), the potential is stepped from Init E to either High E or Low E depending on the Init P/N and may then be stepped back. The following diagram shows the potential waveform applied as a function of time. Current is recorded as a function of time.

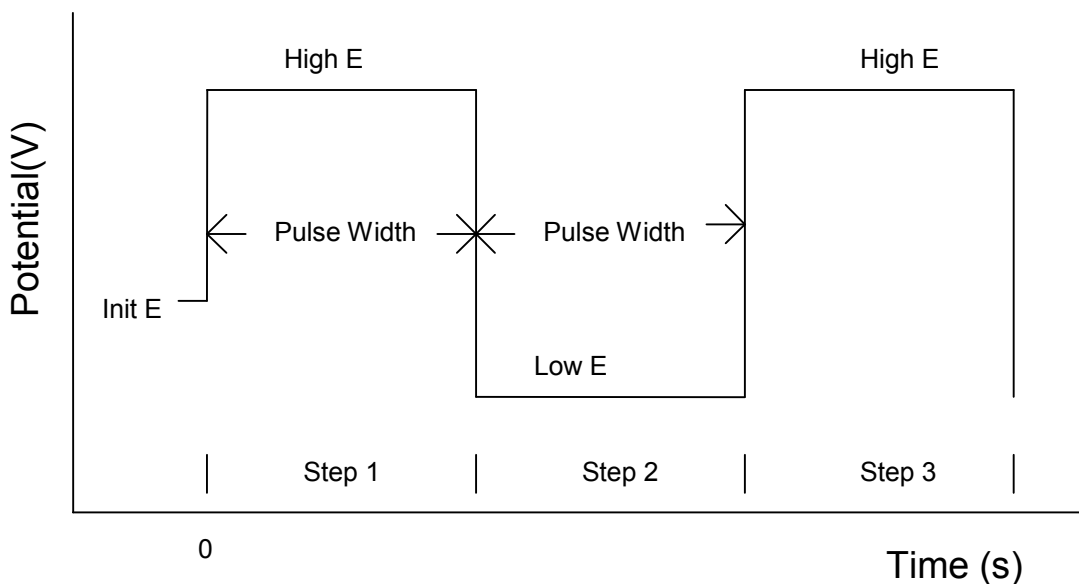

Parameter	Range	Description
Init E (V)	-10 - +10	Initial potential
High E (V)	-10 - +10	Upper limit of potential step
Low E (V)	-10 - +10	Lower limit of potential step
Init P/N	Pos. or Neg.	Initial step direction
Number of Steps	1 - 320	Number of potential steps
Pulse Width (s)	1e-4 - 1000	Potential pulse width
Sample Interval (s)	1e-6 - 10	Data sampling interval
Quiet Time (s)	0 - 100000	Quiescent time before potential step
Sensitivity (A/V)	1e-12 - 0.1	Sensitivity scale
Aux. Signal Rec.	Check or Uncheck	Record external signal when sample interval >= 0.005s

Notes

- High E and Low E should be at least 0.01 V apart.
- If unreasonable values for High E or Low E are entered, the system will automatically readjust them.
- Depending on the Init E, High E, and Low E values, the system will automatically readjust the initial scan direction.
- The maximum potential scan range is 13.1V.
- A shorter sampling interval will increase data density but also reduce the signal-noise ratio. If earlier transient data points are important, a shorter sampling interval is recommended. If later data points are of interest, a longer sampling interval is recommended. However, a minimum of 100 points per step is required.
- If the sampling interval is shorter than 0.002s (or 0.0005s with fast com port speed), data will not be transferred in real time, but rather after the experiment is completed. The cell is turned off during data transfer unless the Cell On between Run option has been enabled using the Cell command. The total number of data points will be limited by the instrument memory size (64K points). The sampling interval may be automatically adjusted to fit the data points in a reasonable range.
- If the sampling interval is longer than 0.002s (or 0.0005s with fast com port speed), data will be transferred in real time during the experiment. The number of data points for each step will be

limited by the instrument memory size (64K points). The sampling interval may be automatically adjusted to fit the data points in a reasonable range.

- If the sampling interval is greater than 0.005s, it is possible to record external voltage signals (e.g., spectroscopic signals) simultaneously with the voltammogram. Use the 9-pin D-connector on the rear panel for signal input. Consult the User's Manual for the pin-out and signal level requirements.

4.2.6 Chronocoulometry Parameters dialog box

In Chronocoulometry (CC), the potential is stepped from Init E to Final E and may then be stepped back. The following diagram shows the potential waveform applied as a function of time. The charge passing through the working electrode is recorded as a function of time.

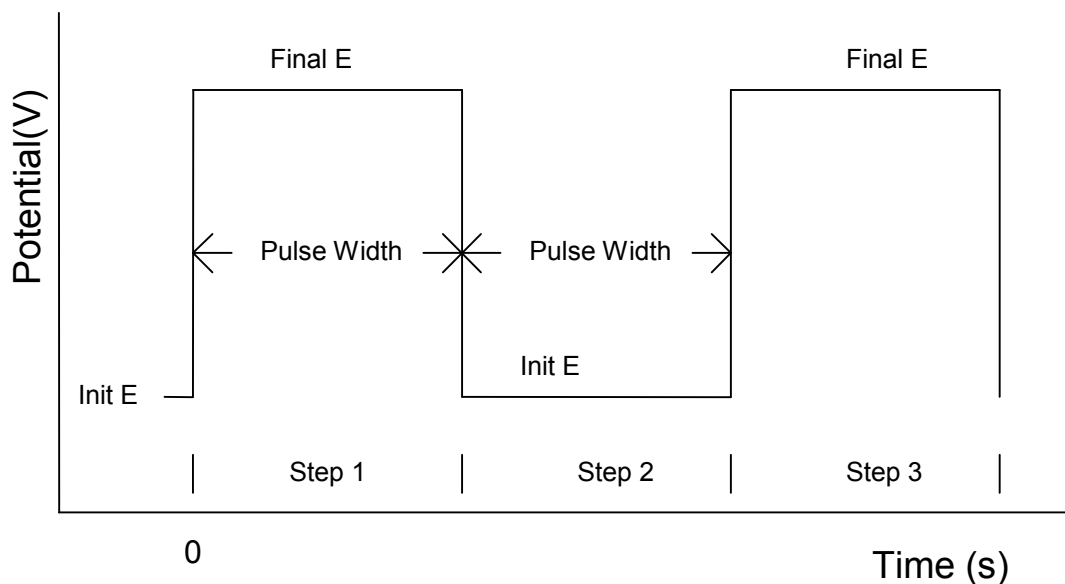

Parameter	Range	Description
Init E (V)	-10 - +10	Initial potential
Final E (V)	-10 - +10	Final potential
Number of Steps	1 - 320	Number of potential steps
Pulse Width (s)	1e-4 - 1000	Potential pulse width
Sample Interval (s)	1e-6 - 10	Data sampling interval
Quiet Time (s)	0 - 100000	Quiescent time before potential step
Sensitivity (A/V)	1e-12 - 0.1 or 1e-9 - 1e-6 C/V	Sensitivity scale

Notes

- Init E and Final E should be at least 0.01 V apart.
- The maximum potential step range is 13.1 V.
- A true integrator (charge-to-voltage converter) can be employed, in which case the sensitivity is 1e-9 to 1e-6 C/V. If charge exceeds 8e-6 coulombs, the capacitor of the integrator will be discharged and the new charge will be added to the previous value. This allows higher charge to be measured with the integrator. There may be discontinuities in the charge-time curve due to this capacitor discharge. These discontinuities should be negligible, but if they turn out to have a significant effect on the measurement, you can use the current-to-voltage converter instead and use the software integrator to convert current to charge.
- A current-to-voltage converter is not ideal for chronocoulometry, particularly if early transient data are important as in double layer capacitance or surface reactions. A charge-to-voltage converter (true integrator) is a better choice.
- If the current-to-voltage converter is employed due to high total charge, a shorter sampling interval will increase data density but also reduce the signal-to-noise ratio. If earlier transient data are important, a shorter sampling interval is recommended. If later data points are of interest, a longer sampling interval is recommended. However, a minimum of 1000 points per step is required unless the sampling rate does not allow it.
- If the sampling interval is shorter than 0.002s (or 0.0005s with fast com port speed), data will not be

transferred in real time, but rather after the experiment is completed. The cell is turned off during data transfer unless the Cell On between Run option has been enabled using the Cell command. The total number of data points will be limited by the instrument memory size (64K points). The sampling interval may be automatically adjusted to fit the data points in a reasonable range.

- If the sampling interval is longer than 0.002s (or 0.0005s with fast com port speed), data will be transferred in real time during the experiment. The number of data points for each step will be limited by the instrument memory size (64K points). The sampling interval may be automatically adjusted to fit the data points in a reasonable range.
- If the current-to-voltage converter is employed, during the run, an “Overflow” warning may appear. This is caused by the current transient immediately following the potential step. If the intercept (which gives information about double layer capacitance and adsorption) of the Anson plot ($Q-t^{1/2}$ plot) is not your primary interest, you need not worry about this. However, if data distortion can be observed visually, you should lower the sensitivity scale.
- In some cases, you may want to use the i/E converter filter to slow the system down, but make sure that the time constant of the filter ($1/\text{cutoff freq}$) is much shorter than the pulse width.
- In order to reduce noise and enhance measurement accuracy, it is recommended to use the highest sensitivity scale possible.

4.2.7 Differential Pulse Voltammetry Parameters dialog box

In Differential Pulse Voltammetry (DPV), the base potential is incremented from Init E toward Final E. A potential pulse is applied. Current is sampled before the potential pulse and at the end of the pulse. The difference between these two current samples is recorded as a function of potential. The following diagram shows the potential waveform applied as a function of time and the current sampling scheme.

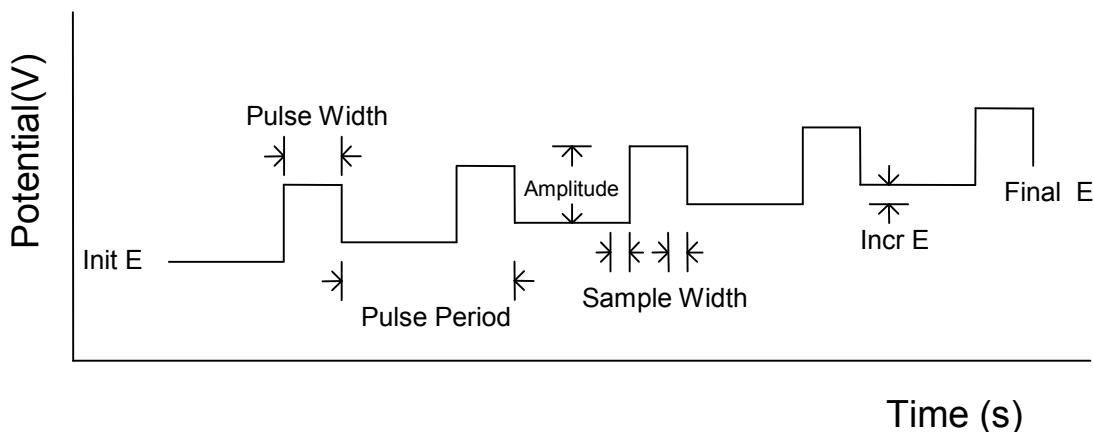

Parameter	Range	Description
Init E (V)	-10 - +10	Initial potential
Final E (V)	-10 - +10	Final potential
Incr E (V)	0.001 - 0.05	Increment potential of each pulse
Amplitude (V)	±0.001 - ±0.5	Potential pulse amplitude
Pulse Width (s)	1e-3 - 10	Potential pulse width
Sample Width (s)	1e-4 - 10	Data sampling width
Pulse Period (s)	0.01 - 50	Potential pulse period or dropping time
Quiet Time (s)	0 - 100000	Quiescent time before potential pulses begin
Sensitivity (A/V)	1e-12 - 0.1	Sensitivity scale

Notes

- Init E and Final E should be at least 0.01 V apart.
- Pulse Width should be no more than half of Pulse Period; otherwise the system will automatically readjust Pulse Width.
- Sample Width should be no more than half of Pulse Width; otherwise the system will automatically readjust Sample Width.
- When Amplitude is negative, the pulse direction will in the opposite direction of the potential scan.

4.2.8 Normal Pulse Voltammetry Parameters dialog box

In Normal Pulse Voltammetry (NPV), the base potential is held at Init E, and a sequence of potential pulses with increasing amplitude is applied. The current at the end of each potential pulse is sampled and recorded as a function of the pulse potential. The following diagram shows the potential waveform applied as a function of time and the current sampling scheme.

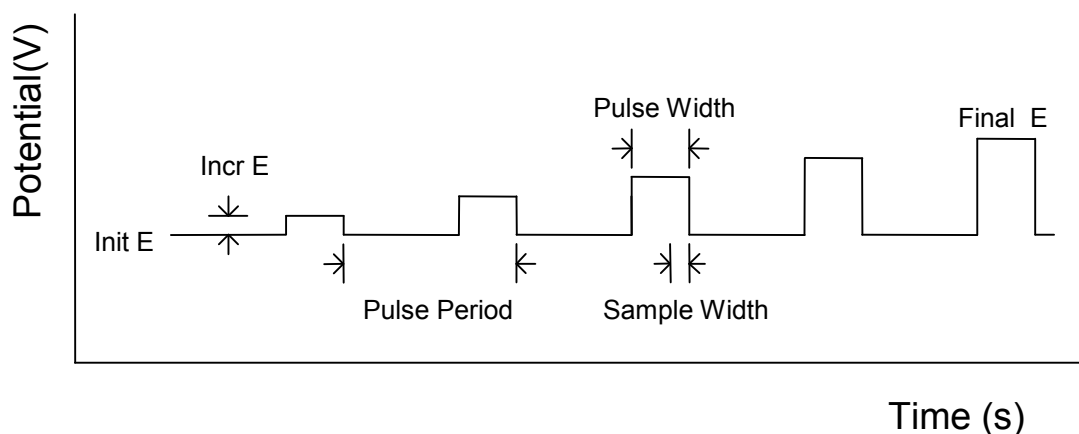

Parameter	Range	Description
Init E (V)	-10 - +10	Initial potential
Final E (V)	-10 - +10	Final potential
Incr E (V)	0.001 - 0.05	Increment potential of each pulse
Pulse Width (s)	1e-3 - 10	Potential pulse width
Sampling Width (s)	1e-4 - 10	Data sampling width
Pulse Period (s)	0.01 - 50	Potential pulse period or dropping time
Quiet Time (s)	0 - 100000	Quiescent time before potential pulses begin
Sensitivity (A/V)	1e-12 - 0.1	Sensitivity scale

Notes

- Init E and Final E should be at least 0.01 V apart.
- Pulse Width should be no more than half of Pulse Period; otherwise the system will automatically readjust Pulse Width.
- Sample Width should be no more than half of Pulse Width; otherwise the system will automatically readjust Sample Width.

4.2.9 Differential Normal Pulse Voltammetry dialog box

In Differential Normal Pulse Voltammetry (DNPV), the base potential is held at Init E, and a sequence of dual potential pulses is applied. The magnitude of the first pulse increments after every iteration, and the second pulse has a constant amplitude relative to the first. Current is sampled at the end of both potential pulses, and the difference of these two values is recorded as a function of the first pulse potential. The following diagram shows the potential waveform applied as a function of time and the current sampling scheme.

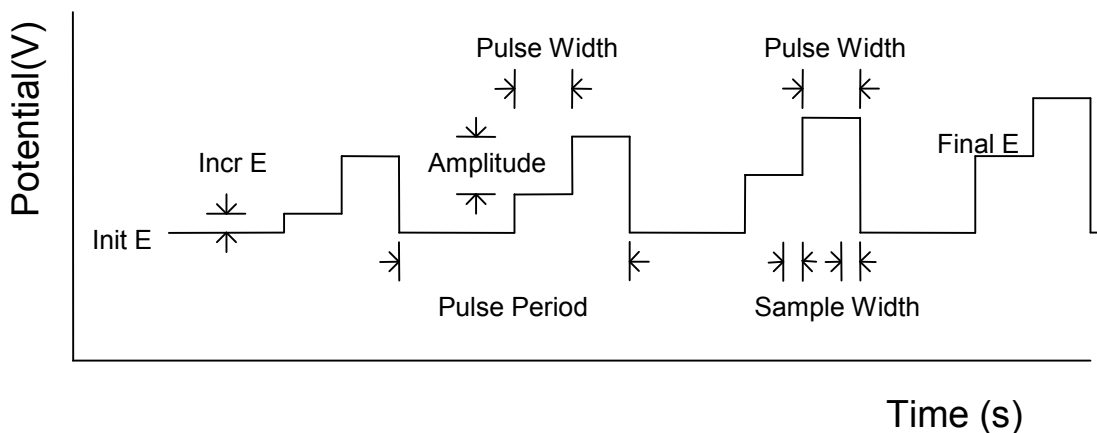

Parameter	Range	Description
Init E (V)	-10 - +10	Initial potential
Final E (V)	-10 - +10	Final potential
Incr E (V)	0.001 - 0.05	Increment potential of each pulse
Amplitude (V)	0.001 - 0.5	Potential pulse amplitude
1st Pulse Width (s)	0.001 - 0.02	First potential pulse width
2nd Pulse Width (s)	0.001 - 0.02	Second potential pulse width
Sampling Width (s)	0.001 - 0.5	Data sampling width
Pulse Period (s)	0.05 - 50	Potential pulse period or dropping time
Quiet Time (s)	0 - 100000	Quiescent time before potential pulses begin
Sensitivity (A/V)	1e-12 - 0.1	Sensitivity scale
Open Circuit	Check or Uncheck	Hold Step 1 at open circuit or constant potential

Notes

- Init E and Final E should be at least 0.01 V apart.
- Pulse Width should be no more than half of Pulse Period; otherwise the system will automatically readjust Pulse Width.
- Sample Width should be no more than half of Pulse Width; otherwise the system will automatically readjust Sample Width.
- In Differential Normal Pulse Voltammetry, consists of three steps (constant potential levels) per cycle. The potential of the first step is normally held at Initial E, where no electrochemical reaction will occur. The second step and third steps are incremented by Incr E every cycle, with the third step always more positive (negative) for a positive (negative) scan than the second potential by Amplitude. Current samples are taken every cycle at the end of the second and third steps, and the difference between the two current samples is reported as a function of the second potential.

4.2.10 Square Wave Voltammetry Parameters dialog box

In Square Wave Voltammetry (SWV), the base potential is incremented from Init E towards Final E. A square wave potential is superimposed onto the base potential, which increments after each cycle of the square wave. Current is sampled at the end of the forward and reverse steps and recorded as a function of the base potential. During the experiment, only the difference between the two current samples is displayed. After the experiment, the forward and reverse currents will also be available for display. The following diagram shows the potential waveform applied as a function of time and the current sampling scheme.

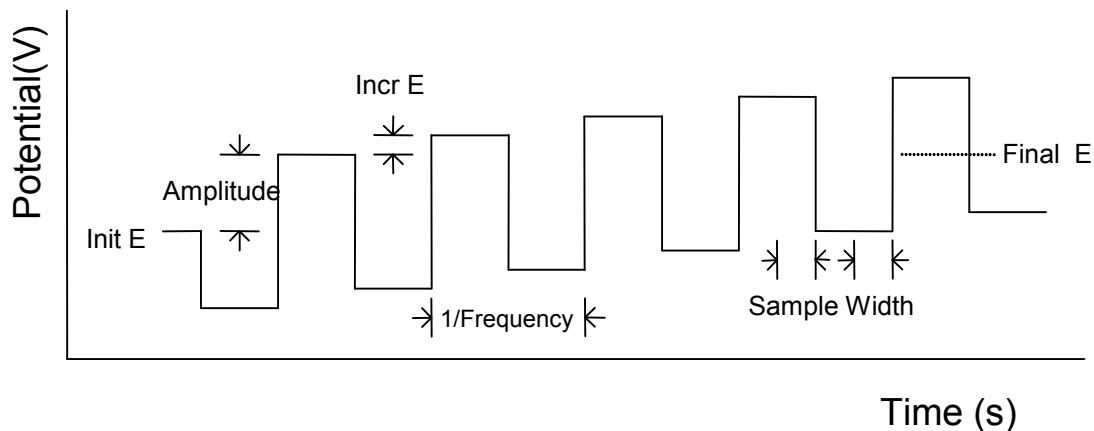

Parameter	Range	Description
Init E (V)	-10 - +10	Initial potential
Final E (V)	-10 - +10	Final potential
Incr E (V)	0.001 - 0.05	Increment potential of each pulse
Amplitude (V)	0.001 - 0.5	Square wave amplitude
Frequency (Hz)	1 - 100000	Square wave frequency
Quiet Time (s)	0 - 100000	Quiescent time before potential pulses begin
Sensitivity (A/V)	1e-12 - 0.1	Sensitivity scale

Notes

- Init E and Final E should be at least 0.01 V apart.
- Forward, reverse, and difference currents are recorded. Use the Graph Option command under the Graphics menu to specify data display options.

4.2.11 AC Voltammetry Parameters dialog box

In [Second Harmonic] AC Voltammetry ([SH]ACV), the base potential is incremented from Init E toward Final E, and a sequential sine waveform is superimposed. Current is sampled when the AC signal is applied, and its second harmonic component is analyzed using a software lock-in amplifier. During the experiment, only the absolute [second harmonic] AC current is displayed. After the experiment, the phase-selective [second harmonic] current at any phase angle will also be available for display. The following diagram shows the potential waveform applied as a function of time.

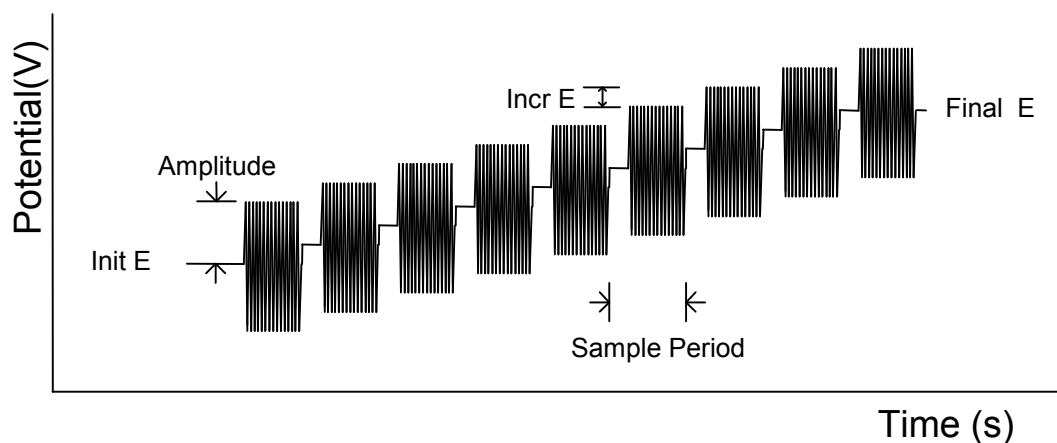

Parameter	Range	Description
Init E (V)	-10 - +10	Initial potential
Final E (V)	-10 - +10	Final potential
Incr E (V)	0.001 - 0.05	Increment potential of each pulse
Amplitude (V)	0.001 - 0.5	AC amplitude
Frequency (Hz)	0.1 - 10000	AC frequency
Sample Period (s)	0.1 - 50	Data sampling period or dropping time
Quiet Time (s)	0 - 100000	Quiescent time before potential pulses begin
Sensitivity (A/V)	1e-12 - 0.1	Sensitivity scale
Bias DC Current	off - range - on	Enable DC current bias during run
Auto Sens	Check or Uncheck	Automatic sensitivity switching during run

Notes

- Init E and Final E should be at least 0.01 V apart.
- Depending on the frequency range, it may not be possible to generate the requested AC frequency; in this case, the closest available frequency will be applied.
- When the AC frequency is 2 Hz or lower, the Sample Period parameter should be at least 2 seconds; if not, the system will automatically readjust the Sample Period.
- Both absolute current and phase-selective current are available. Use the Graph Option command under the Graphics menu to specify data display options.
- When DC current is high and AC current is low, sensitivity cannot be increased because the DC current will overflow. This problem is more serious when the frequency is relatively low. The application of a DC current bias allows higher AC signal amplification. A 16-bit DAC is used for this purpose. On the other hand, if the DC current is not expected to be large and the frequency is high, a DC current bias may be unnecessary.

4.2.12 2nd Harmonic AC Voltammetry Parameters dialog box

In [Second Harmonic] AC Voltammetry ([SH]ACV), the base potential is incremented from Init E toward Final E, and a sequential sine waveform is superimposed. Current is sampled when the AC signal is applied, and its second harmonic component is analyzed using a software lock-in amplifier. During the experiment, only the absolute [second harmonic] AC current is displayed. After the experiment, the phase-selective [second harmonic] current at any phase angle will also be available for display. The following diagram shows the potential waveform applied as a function of time.

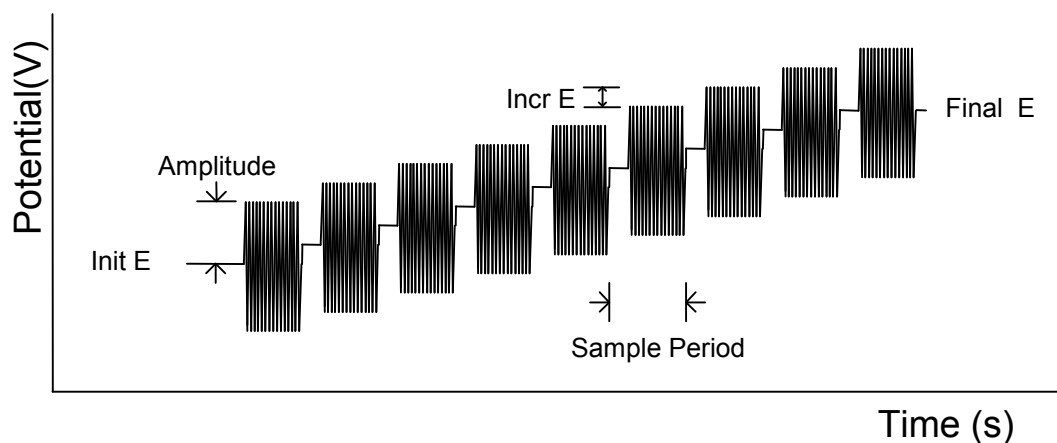

Parameter	Range	Description
Init E (V)	-10 - +10	Initial potential
Final E (V)	-10 - +10	Final potential
Incr E (V)	0.001 - 0.05	Increment potential of each pulse
Amplitude (V)	0.001 - 0.5	AC amplitude
Frequency (Hz)	0.1 - 5000	AC frequency
Sample Period (s)	0.1 - 50	Data sampling period or dropping time
Quiet Time (s)	0 - 100000	Quiescent time before potential pulses begin
Sensitivity (A/V)	1e-12 - 0.1	Sensitivity scale
Bias DC Current	off - range - on	Enable DC current bias during run
Auto Sens	Check or Uncheck	Automatic sensitivity switching during run

Notes

- Init E and Final E should be at least 0.01 V apart.
- Depending on the frequency range, it may not be possible to generate the requested AC frequency; in this case, the closest available frequency will be applied.
- When the AC frequency is 2 Hz or lower, the Sample Period parameter should be at least 2 seconds; if not, the system will automatically readjust the Sample Period.
- Both absolute current and phase-selective current are available. Use the Graph Option command under the Graphics menu to specify data display options.
- When DC current is high and AC current is low, sensitivity cannot be increased because the DC current will overflow. This problem is more serious when the frequency is relatively low. The application of a DC current bias allows higher AC signal amplification. A 16-bit DAC is used for this purpose. On the other hand, if the DC current is not expected to be large and the frequency is high, a DC current bias may be unnecessary.

4.2.13 FT AC Voltammetry Parameters dialog box

In Fourier Transform AC Voltammetry (FTACV), the DC potential is scanned from Init E to Final E in increments of 0.3 mV. On top of this DC scan, a sine waveform is superimposed, applied continuously without interruption. The resulting current is sampled and displayed directly at all times (cf. ACV). Once the experiment is complete, data analysis by Fourier transform yields the absolute AC current, DC current, first, second, third, and fourth harmonic components, as well as the complete response spectrum. Hence, a very rich set of information can be obtained from a single measurement.

Parameter	Range	Description
Init E (V)	-10 - +10	Initial potential
Final E (V)	-10 - +10	Final potential
Frequency (Hz)	0.1 - 50	AC frequency
Amplitude (V)	0.001 - 0.5	AC amplitude
Total Data Point	8192 - 65536	Total number of data points sampled
Data Points Per Sine	4 - 256	Number of data points per AC waveform period
Sweep Segments	1 - 2	Single or cyclic DC potential scan
Quiet Time (s)	0 - 100000	Quiescent time before potential scan
Sensitivity (A/V)	1e-12 - 0.1	Sensitivity scale

Notes

- Init E and Final E should be at least 0.01 V apart.
- For a given frequency, the more data points per sine wave, the faster the sampling rate will be. Faster sampling will result in less noise (more signal averaging), but lower data density. If the specified sampling rate exceeds 3 KHz, data will be displayed at the end of the experiment instead of in real time.
- The total measurement time in seconds is equal to the total number of points / points per sine wave / frequency.
- The potential scan rate in turn is equal to the specified potential range divided by the total measurement time.
- The absolute AC current, DC current, first, second, third, and fourth harmonic components, and the complete response spectrum can be plotted using the Graph Option command under the Graphics menu.

4.2.14 Amperometric i-t Curve dialog box

In the Amperometric i-t Curve technique (i-t), a constant potential is applied, and current is recorded as a function of time. The following diagram shows the potential waveform applied as a function of time and the current sampling scheme.

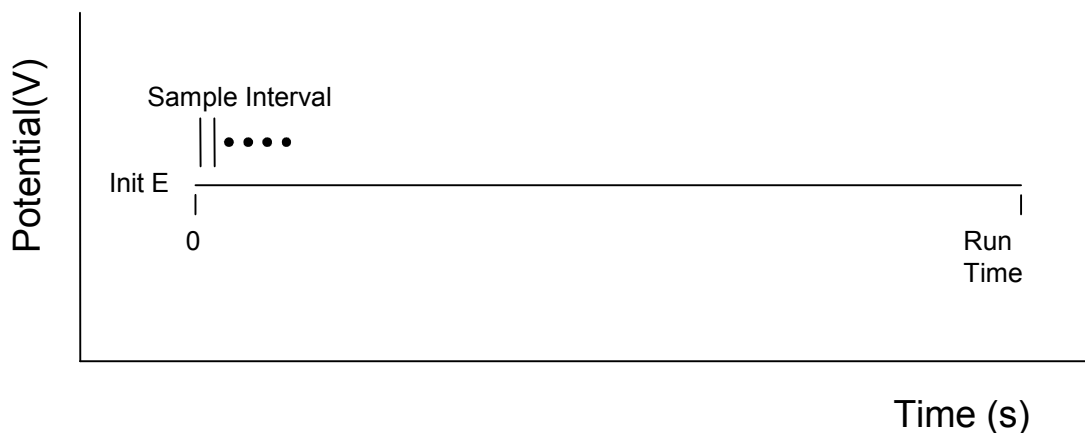

Parameter	Range	Description
Init E (V)	-10 - +10	Initial potential
Sample Interval (s)	1e-6 - 50	Data sampling interval
Run Time (s)	0.001 - 500000	Total measurement time
Quiet Time (s)	0 - 100000	Quiescent time before potential step
Scales During Run	1, 2, 3	Number of current display scales
Sensitivity (A/V)	1e-12 - 0.1	Sensitivity scale
Aux. Signal Rec.	Check or Uncheck	Record external signal when sample interval > 0.005 s

Notes

- The data sampling interval should be chosen according to the length of the experiment. The longer the experiment, the longer the sampling interval should be. A longer sampling interval results in more signal averaging and less noise.
- During an experiment, whenever the data exceed the maximum allowed points, the data storage interval will be doubled automatically. Therefore, data points will not overflow for an unexpectedly long experiment.
- If the sampling interval is greater than 0.005s, it is possible to record external voltage signals (e.g., spectroscopic signals) simultaneously with the amperometric i-t response. Use the 9-pin D-connector on the rear panel for signal input. Consult the User's Manual for the pin-out and signal level requirements.
- When only 1 current scale is displayed during a run, the data will be automatically scaled to fit. When 2 current scales are displayed during a run, they will be 1/100 and 1/10 of full scale. When 3 current scales are displayed, they will be 1/100, 1/10, and 1/1 of full scale.

4.2.15 Differential Pulse Amperometry dialog box

In Differential Pulse Amperometry (DPA), a cleaning potential can be applied for electrode conditioning, during which current is not sampled. Two potential pulses are applied after the cleaning step, and the current at the end of each pulse is recorded as a function of time. During the experiment, only the difference between the two current samples is displayed. After the experiment, the current responses to the two potential pulses will also be available for display. The following diagram shows the potential waveform applied as a function of time and the current sampling scheme.

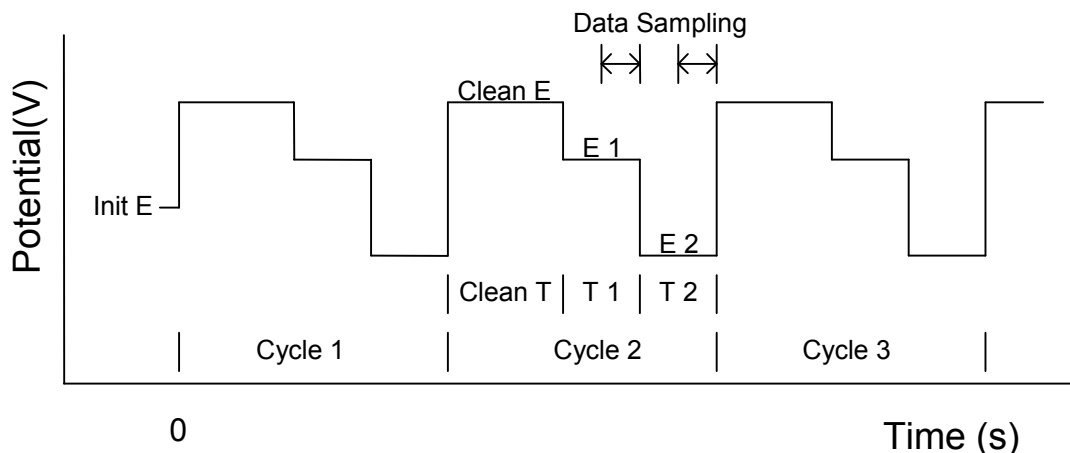

Parameter	Range	Description
Init E (V)	-10 - +10	Initial potential
Cleaning E (V)	-10 - +10	Electrode cleaning potential
Cleaning Time (s)	0 - 32	Electrode cleaning time
Pulse E1 (V)	-10 - +10	First pulse potential
Pulse T1 (s)	0.01 - 32	First pulse time
Pulse E2 (V)	-10 - +10	Second pulse potential
Pulse T2 (s)	0.01 - 32	Second pulse time
Number of Cycles	10 - 100000	Number of Repetitive Cycles
Quiet Time (s)	0 - 100000	Quiescent time before potential pulses begin
Scales During Run	1, 2, 3	Number of current display scales
Sensitivity (A/V)	1e-12 - 0.1	Sensitivity scale
Open Circ. Clean.	Check or Uncheck	Cleaning step held at constant or open circuit potential

Notes

- The experimental sequence consists of a cleaning step, the first pulse, and the second pulse. This sequence is repeated until the total number of cycles is reached or the experiment is interrupted by the user. There is no data acquisition during the cleaning step; if the cleaning time is zero, this step will be ignored. Data are sampled for first and second pulses and the difference is reported.
- Data sampling occurs during the second half-period of pulses 1 and 2. The longer the pulse width, the longer the sample interval will be, resulting in better signal averaging and less noise.
- During an experiment, whenever the data exceed the maximum allowed points, the data storage interval will be doubled automatically. Therefore, data points will not overflow for an unexpectedly long experiment.
- When only 1 current scale is displayed during a run, the data will be automatically scaled to fit. When 2 current scales are displayed during a run, they will be 1/100 and 1/10 of full scale. When 3 current scales are displayed, they will be 1/100, 1/10, and 1/1 of full scale.

4.2.16 Double Differential Pulse Amperometry dialog box

Double Differential Pulse Amperometry (DDPA) alternates between two instances of differential pulse amperometry, with two sets of data recorded and displayed. In each instance, a cleaning potential can be applied for electrode conditioning, during which current is not sampled. Two potential pulses are applied after the cleaning step, and the current at the end of each pulse is recorded as a function of time. During the experiment, only the difference between the two current samples is displayed. After the experiment, the current responses to the two potential pulses will also be available for display. The following diagram shows the potential waveform applied as a function of time and the current sampling scheme.

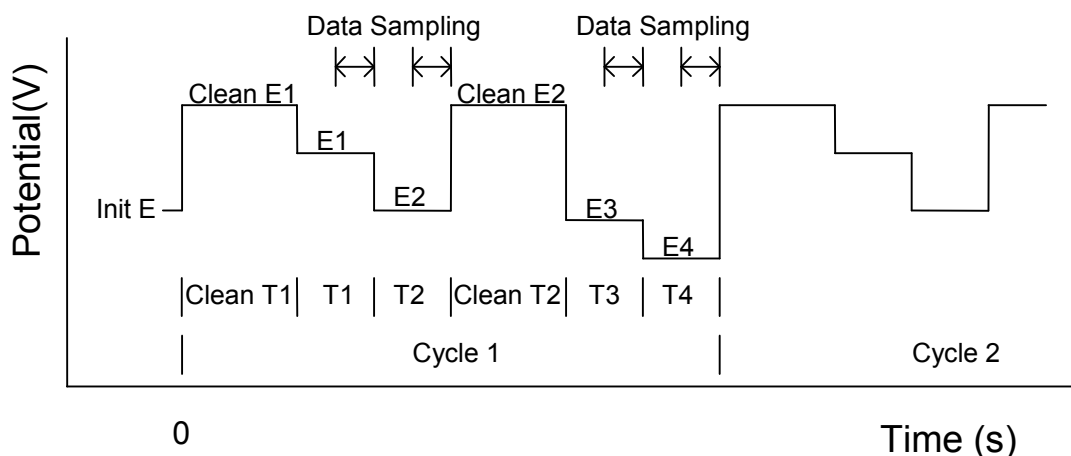

Parameter	Range	Description
<i>First DPA:</i>		
Cleaning E1 (V)	-10 - +10	Electrode cleaning potential
Cleaning Time (s)	0 - 32	Electrode cleaning time
Pulse E1 (V)	-10 - +10	First pulse potential
Pulse T1 (s)	0.01 - 32	First pulse time
Pulse E2 (V)	-10 - +10	Second pulse potential
Pulse T2 (s)	0.01 - 32	Second pulse time
Open Circ. Clean.	Check or Uncheck	Cleaning step held at constant or open circuit potential
<i>Second DPA:</i>		
Cleaning E2 (V)	-10 - +10	Electrode cleaning potential
Cleaning Time (s)	0 - 32	Electrode cleaning time
Pulse E1 (V)	-10 - +10	First pulse potential
Pulse T1 (s)	0.01 - 32	First pulse time
Pulse E2 (V)	-10 - +10	Second pulse potential
Pulse T2 (s)	0.01 - 32	Second pulse time
Open Circ. Clean.	Check or Uncheck	Cleaning step held at constant or open circuit potential
Init E (V)	-10 - +10	Initial potential
Number of Cycles	10 - 100000	Number of Repetitive Cycles
Quiet Time (s)	0 - 100000	Quiescent time before potential pulses begin
Scales During Run	1, 2, 3	Number of current display scales
Sensitivity (A/V)	1e-12 - 0.1	Sensitivity scale

Notes

- The experimental sequence consists of the first DPA cleaning, a first pulse, and a second pulse, followed by a second DPA cleaning, a third pulse, and a fourth pulse. This sequence is repeated until the total number of cycles is reached or the experiment is interrupted by the user. There is no data acquisition during the cleaning steps; if the cleaning time is zero, the cleaning step will be

ignored. Data are sampled for first and second pulses and the difference is reported.

- Data sampling occurs during the second half-period of pulses 1 and 2. The longer the pulse width, the longer the sample interval will be, resulting in better signal averaging and less noise.
- During an experiment, whenever the data exceed the maximum allowed points, the data storage interval will be doubled automatically. Therefore, data points will not overflow for an unexpectedly long experiment.
- When only 1 current scale is displayed during a run, the data will be automatically scaled to fit. When 2 current scales are displayed during a run, they will be 1/100 and 1/10 of full scale. When 3 current scales are displayed, they will be 1/100, 1/10, and 1/1 of full scale.
- To specify options to display data for the first or second DPA or both, use the Graph Option command under the Graphics menu.

4.2.17 Triple Pulse Amperometry Parameters dialog box

In Triple Pulse Amperometry (TPA), three potential pulses are applied. The first two pulses are for electrode conditioning or cleaning. Current is sampled at the end of the third potential pulse and recorded as a function of time. The third potential pulse can be constant or incremented after each cycle. The following diagram shows the potential waveform applied as a function of time and the current sampling scheme.

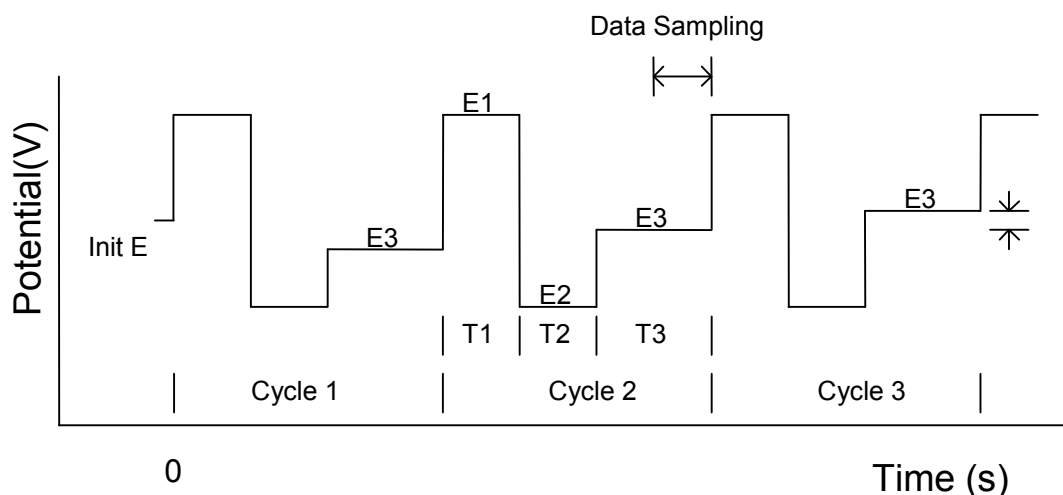

Parameter	Range	Description
E1 (V)	-10 - +10	First pulse potential
Duration 1 (s)	0 - 32	First pulse duration
Open Circuit	Check or Uncheck	Hold step 1 at open circuit or constant potential
E2 (V)	-10 - +10	Second pulse potential
Duration 2 (s)	0 - 32	Second pulse duration
E3 (V)	-10 - +10	Third pulse potential
Duration 3 (s)	0.01 - 32	Third pulse duration
Incr E (V)	0 - 0.02	Increment potential for third step
Init E (V)	-10 - +10	Initial potential during quiescent time
Final E (V)	-10 - +10	Final potential for scan
Number of Cycles	10 - 100000	Number of Repetitive Cycles
Quiet Time (sec)	0 - 100000	Quiescent time before taking data
Scales During Run	1, 2, 3	Number of current display scales
Sensitivity (A/V)	1e-12 - 0.1	Sensitivity scale

Notes

- The experimental sequence consists of three pulses. This sequence is repeated until the total number of cycles is reached or the experiment is interrupted by the user. There is no data acquisition during the first two pulses, which are used for electrode cleaning purposes; data are sampled only for the third pulse. If the first or second pulse time is zero, the corresponding step will be ignored.
- If the increment potential is non-zero, the experiment will start at E3 and end at Final E. E3 and Final E should be at least 0.01 V apart. The number of cycles will have no effect.
- Data sampling occurs during the second half-period of pulse 3. The longer the pulse width, the longer the sample interval will be, resulting in better signal averaging and less noise
- During an experiment, whenever the data exceed the maximum allowed points, the data storage

interval will be doubled automatically. Therefore, data points will not overflow for an unexpectedly long experiment.

- When only 1 current scale is displayed during a run, the data will be automatically scaled to fit. When 2 current scales are displayed during a run, they will be 1/100 and 1/10 of full scale. When 3 current scales are displayed, they will be 1/100, 1/10, and 1/1 of full scale.

4.2.18 Integrated Pulsed Amperometric Detection Parameters dialog box

In Integrated Pulse Amperometric Detection (IPAD), six segments of potential sweeps or steps are applied. Current is sampled and integrated during the first four segments. Electrode conditioning or cleaning occurs during the last two steps. The integrated current is averaged and recorded as a function of time. The following diagram shows the potential waveform applied as a function of time and the current sampling scheme.

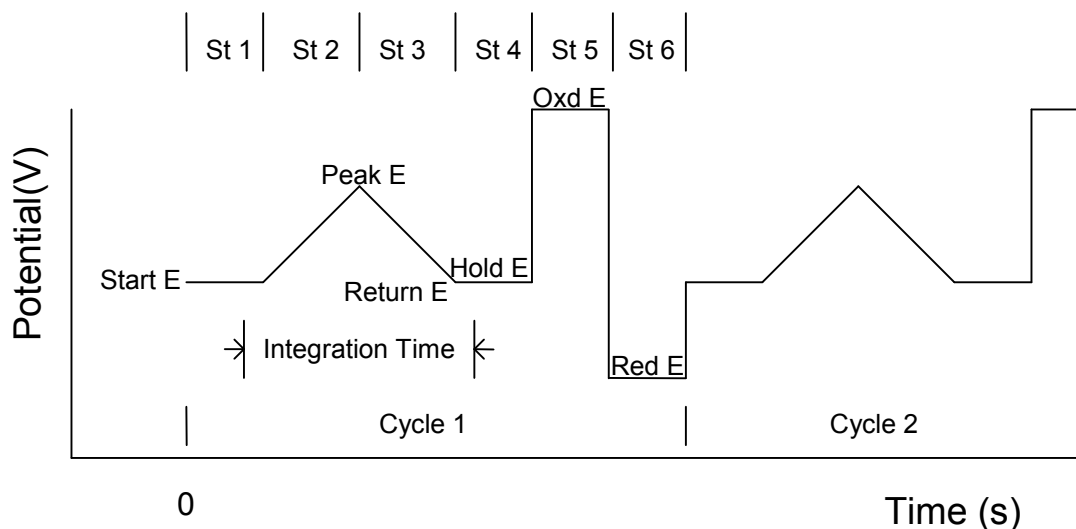

Parameter	Range	Description
Step 1: Start		
Start E (V)	-3.276 - +3.276	Start potential (constant)
Hold Time (s)	0.05 - 1	Start potential duration (current integration for last 10 ms)
Step 2: For. Scan		
Peak E (V)	-3.276 - +3.276	Potential is scanned Start E to Peak E
Scan Time (s)	0.15 - 1	Potential scan time (current integration continues)
Step 3: Rev. Scan		
Return E (V)	-3.276 - +3.276	Potential is scanned Peak E to Return E (often Start E)
Scan Time (s)	0.15 - 1	Potential scan time (current integration continues)
Step 4: Hold		
Hold E (V)	-3.276 - +3.276	Hold potential (constant)
Hold Time (s)	0.05 - 1	Hold potential duration (current integration for first 10 ms)
Step 5: Oxidation		
Oxd E (V)	-3.276 - +3.276	Oxidation potential for electrode treatment
Oxd Time (s)	0.05 - 1	Oxidation time duration
Step 6: Reduction		
Red E (V)	-3.276 - +3.276	Reduction potential for electrode treatment
Red Time (s)	0.05 - 1	Reduction time duration
Number of Cycles	5 - 65535	Number of cycles through six steps
Quiet Time (s)	0 - 100000	Quiescent time before potential scan
Sensitivity (A/V)	1e-12 - 0.1	Sensitivity scale

Notes

- The experimental sequence consists of a constant starting potential, forward potential scan, reverse potential scan, hold potential, oxidation potential, and reduction potential. This sequence will be repeated until the total number of cycles is reached or interrupted by the user.
- Current is sampled during the last 10 msec of the start potential, forward scan, reverse scan, and the first 10 msec of the hold potential. The current are integrated and reported.
- During an experiment, whenever the data exceed the maximum allowed points, the data storage interval will be doubled automatically. Therefore, data points will not overflow for an unexpectedly long experiment.

4.2.19 Bulk Electrolysis with Coulometry Parameters dialog box

In Bulk Electrolysis with Coulometry (BE), a constant potential is applied and the integrated charge is recorded as a function of time. The following diagram shows the potential waveform applied as a function of time and the sampling scheme.

A preelectrolysis step can be applied to reduce interference and background current.

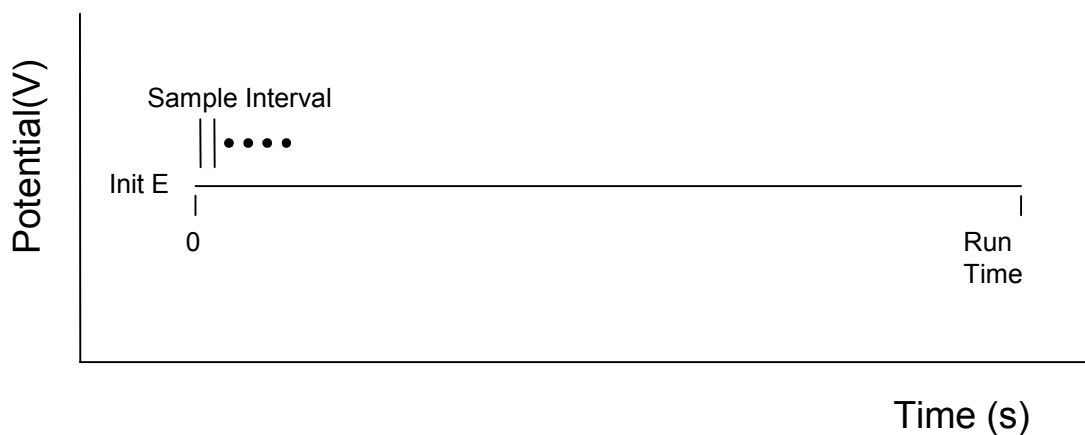

Parameter	Range	Description
Electrolysis E (V)	-10 - +10	Electrolysis potential
End Current Ratio	0 - 100%	Upper limit of potential step
Data Stor. Int. (s)	0.01 - 100	Data display and storage interval
Preelec. E (V)	-10 - +10	Preelectrolysis potential
Preelec. T. (s)	0 - 1000000	Preelectrolysis time

Notes

- Before electrolysis, a preelectrolysis step can be performed, which is useful for reducing residual current. Any current at the end of preelectrolysis will be regarded as residual current and be subtracted from the total charge to give the net charge. If preelectrolysis time is set to zero, this step is ignored. You can stop preelectrolysis at any time by invoking the Stop command, and the regular electrolysis will follow immediately.
- The sensitivity scale will be switched automatically during the experiment.
- The current ratio is reported relative to the initial current. If the data storage interval is 1 second, the initial current is the average current of the first second after electrolysis begins.
- If the specified end current ratio is zero, electrolysis will continue forever. In order to stop the experiment, the Stop command should be invoked.
- During the experiment, the data will be updated at the same rate that data storage occurs (i.e., will be dictated by the data storage interval).
- The data sampling interval should be chosen according to the length of the experiment. The longer the experiment, the longer the sampling interval should be. A longer sampling interval results in more signal averaging and less noise. However, for a thin layer cell, a short data storage time should be chosen in order to observe the electrolysis process in detail.
- During an experiment, whenever the data exceed the maximum allowed points, the data storage interval will be doubled automatically. Therefore, data points will not overflow for an unexpectedly long experiment.

4.2.20 Hydrodynamic Modulation Voltammetry Parameters dialog box

In Hydrodynamic Modulation Voltammetry (HMV), the potential is incremented from Init E toward Final E. The following diagram shows the potential waveform applied as a function of time. At each potential, the rotating speed of the RDE is modulated. The resulting alternating current is sampled and analyzed using a software lock-in amplifier. During the experiment, only the absolute AC current is displayed. After the experiment, the phase-selective current at any phase angle will also be available for display. The AC current is sampled at every potential increment and recorded as a function of potential.

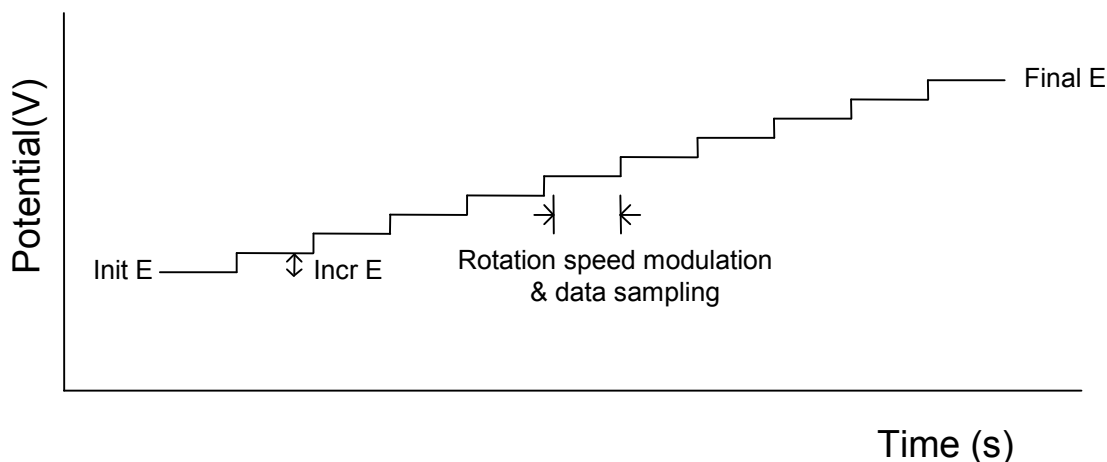

Parameter	Range	Description
Init E (V)	-10 - +10	Initial potential
Final E (V)	-10 - +10	Final potential
Incr E (V)	0.001 - 0.02	Increment potential of each step
Rot. Rate (rpm)	0 - 10000	Center rotation rate
Modul Freq. (Hz)	1 - 5	Modulation frequency
Modul Amp. (rpm)	0 - 3600	Modulation amplitude (see Notes or Equations)
Quiet Time (s)	0 - 100000	Quiescent time before potential pulses begin
Sensitivity (A/V)	1e-12 - 0.1	Sensitivity scale

Notes

- Init E and Final E should be at least 0.01 V apart.
- The actual rotation rate in hydrodynamic modulation is given by $\omega^{1/2} = \omega_0^{1/2} + \Delta\omega^{1/2} \sin(\sigma t)$
- The modulation function is a periodic waveform with modulation frequency σ but more complicated than a sine wave. The rotation rate oscillates about ω_0 (rotation rate), but the amplitude of this oscillation is not symmetric. The input parameter $\Delta\omega$ (modulation frequency) is not really the amplitude, but the square of $\Delta\omega^{1/2}$ in the equation above.

4.2.21 Sweep Step Function Parameters dialog box

In the Sweep-Step Functions technique (SSF), the instrument alternates between six potential sweeps and six potential steps, somewhat like an arbitrary waveform generator. The following diagram shows the potential waveform applied as a function of time. One can skip any segment by setting parameters sufficiently small, allowing enhanced flexibility for waveform control. Current is recorded as a function of time; for sweep segments, it can also be presented as a function of potential.

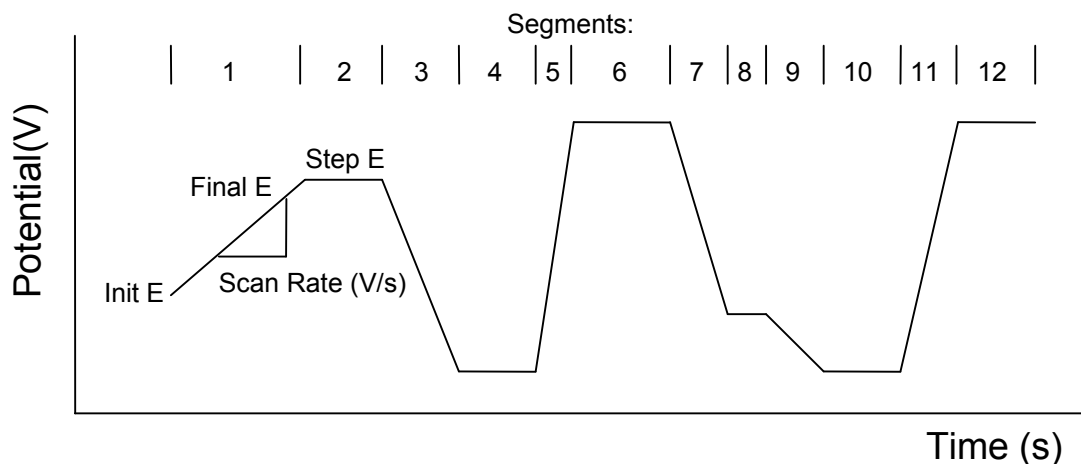

Parameter	Range	Description
Seq. 1,3,5,7,9,11		
Sweep:		
Init E (V)	-10 - +10	Initial potential
Final E (V)	-10 - +10	Final potential
Scan Rate (V/s)	1e-4 - 50	Potential scan rate
Seq. 2,4,6,8,10,12		
Step:		
Step E (V)	-10 - +10	Step potential
Step Time (s)	0 - 10000	Step duration
Init E (V)	-10 - +10	Initial potential
Sweep S.I. (V)	0.001 - 0.05	Sweep function sampling interval
Step S.I. (s)	0.0001 - 1	Step function sampling interval
Quiet Time (s)	0 - 100000	Quiescent time before potential scan
Sensitivity (A/V)	1e-12 - 0.1	Sensitivity scale

Notes

- A Sweep sequence will be ignored if the difference between its Init E and Final E is less than 0.01 V.
- A Step sequence will be ignored if its step time is less than 0.001 sec or its number of points is less than 3. To remedy the latter case, either increase its step time or decrease its sampling interval.
- If the scan rate for a Sweep sequence is less than 0.5 V/s, data will be transferred and displayed in real time.
- If the sampling interval for a Step sequence is larger than 0.002 sec, data will be transferred and displayed in real time.
- The potential differences between Init E, Final E, and Step E should be less than 13.1 V.

4.2.22 Multi-Potential Steps Parameters dialog box

In the Multi-Potential Steps technique (STEP), twelve potential steps can be applied and cycled. Current is recorded as a function of time. The following diagram shows the potential waveform applied as a function of time.

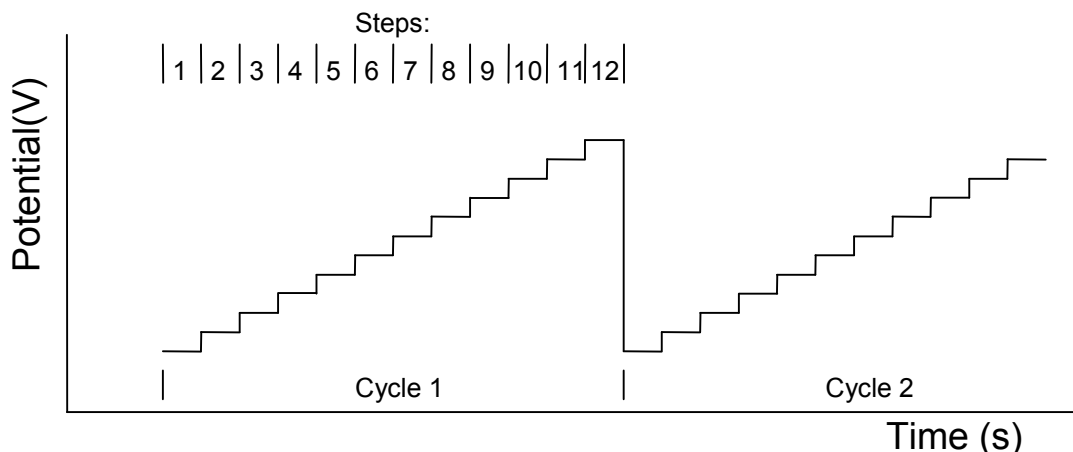

Parameter	Range	Description
Step Seq. 1-12		
Step E (V)	-10 - +10	Step potential
Step Time (s)	0 - 10000	Step duration
Init E (V)	-10 - +10	Initial potential
No. of Cycles	1 - 10000	Number of cycles
Smpl Intv (s)	0.0001 - 1	Sampling interval
Quiet Time (s)	0 - 100000	Quiescent time before potential scan
Sensitivity (A/V)	1e-12 - 0.1	Sensitivity scale
E1 On	Check or Uncheck	Working electrode 1 on/off control

Notes

- A step will be ignored if its step time is less than 0.001 sec or shorter than its sampling interval.
- If the sampling interval for a Step sequence is larger than 0.002 sec, data will be transferred and displayed in real time.
- The sampling interval will be automatically increased if (step time * cycles / sample interval) exceeds 64K if data is to be transferred after the experiment.
- If the sampling interval is larger than 0.002 sec, data will be transferred and displayed in real time.
- The potential difference between Init E, Final E, and Step E should be less than 13.1 V.

4.2.23 A.C. Impedance Parameters dialog box

In the AC Impedance technique (IMP), the base potential is held constant at Init E. A sine waveform is superimposed onto the base potential, and its frequency is scanned from high to low with 12 components per decade. Current and potential are sampled and analyzed to obtain the real and imaginary parts of the impedance. During the experiment, you can switch between a Bode plot and a Nyquist plot by right-clicking. After the experiment, impedance data can be presented in various forms. The following diagram shows the potential waveform applied as a function of time.

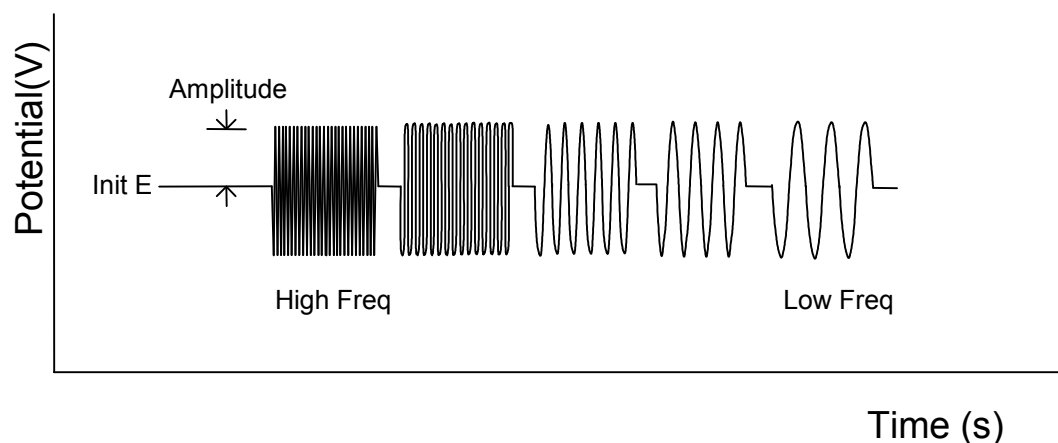

Parameter	Range	Description
Init E (V)	-10 - +10	Initial potential
High Freq. (Hz)	1e-4 - 2e6	High frequency limit
Low Freq. (Hz)	1e-5 - 1e5	Low frequency limit
Amplitude (V)	1e-5 - 0.7	A.C. amplitude
Quiet Time (s)	0 - 100000	Quiescent time before potential scan
Sensitivity Scale	Select	Automatic or Manual
Meas. Mode	FT - Single - Galv.	Select measurement mode above 100 Hz
Avg (1K-1M Hz)	0.1 - 4	Average factors
Avg (1-999 Hz)	1 - 256	Average factors
Cycles (0.1-1 Hz)	1 - 25	Number of cycles at each frequency point
Cycles (0.01-0.1)	1 - 25	Number of cycles at each frequency point
Cycles (1e-3-1e-2)	1 - 25	Number of cycles at each frequency point
Cycles (1e-4-1e-3)	1 - 25	Number of cycles at each frequency point
Cycles (1e-5-1e-4)	1 - 4	Number of cycles at each frequency point
Points (all freqs)	2 - 100	Number of points per decade frequency
Bias DC Current	off - range - on	Enable DC current bias during run

Notes

- Above 100 Hz, both current and potential are measured in order to calculate impedance. 12 frequency components per decade will be measured. In the Fourier transform case, each measurement covers a decade of frequency range. Below 100 Hz, only current is measured. The applied potential is assumed to have no extra phase shift and be accurate.
- When DC current is high and AC current is low, sensitivity cannot be increased because the DC current will overflow. This problem is more serious when the frequency is relatively low. The application of a DC current bias allows higher AC signal amplification. A 16-bit DAC is used for this purpose. On the other hand, if the DC current is not expected to be large and the frequency is high, a DC current bias may be unnecessary.
- The power line frequency (50 or 60 Hz, depending on your region) can interfere with measurements. Use a longer measurement time between 1-100Hz to improve data quality of this frequency range.
- Automatic sensitivity scale is used by default. The sensitivity scale setting can also be manually overridden by clicking the Manual button top open the Manual Sensitivity Setting dialog box.

4.2.24 Impedance - Time Parameters dialog box

In the Impedance - Time technique (IMPT), the base potential is held constant at Init E, onto which a sine waveform is superimposed. Current and potential are sampled and analyzed to obtain the real and imaginary parts of the impedance as a function of time. The following diagram shows the potential waveform applied as a function of time.

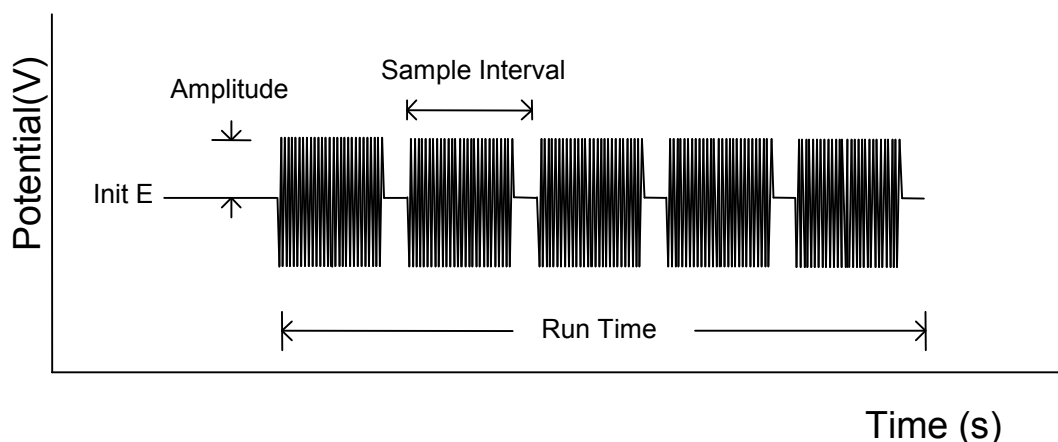

Parameter	Range	Description
Init E (V)	-10 - +10	Initial potential
Amplitude (V)	0.0001 - 1.5	A.C. amplitude
Frequency (Hz)	0.0001 - 1e6	A.C. frequency
Sample Interval (s)	1 - 20000	Data sampling interval
Run Time (s)	1 - 500000	Total experiment time
Cycles (< 10 Hz)	1 - 100	Number of repetitive cycles at each frequency
Quiet Time (s)	0 - 100000	Quiescent time before sampling data
Bias DC Current	off - range - on	Enable DC current bias during run
Sensitivity Scale	1e-12 - 0.1	Sensitivity scale (automatic or manual)

Notes

- If the sampling interval is smaller than the actual time required for sampling, it will be automatically adjusted.
- More cycles result in a better signal-to-noise ratio but also a longer experiment run time.
- When DC current is high and AC current is low, sensitivity cannot be increased because the DC current will overflow. This problem is more serious when the frequency is relatively low. The application of a DC current bias allows higher AC signal amplification. A 16-bit DAC is used for this purpose. On the other hand, if the DC current is not expected to be large and the frequency is high, a DC current bias may be unnecessary.
- Automatic sensitivity scale is used by default. During the experiment, the system tests the current size and determines the proper sensitivity scale. This usually works pretty well. The sensitivity scale setting can also be manually overridden, which may yield better results in certain cases.

4.2.25 Impedance - Potential Parameters dialog box

In the Impedance - Potential technique (IMPE), the base potential is incremented from Init E toward Final E, onto which a sequential sine waveform is superimposed. Current and potential are sampled and analyzed to obtain the real and imaginary parts of the impedance as a function of potential. The following diagram shows the potential waveform applied as a function of time.

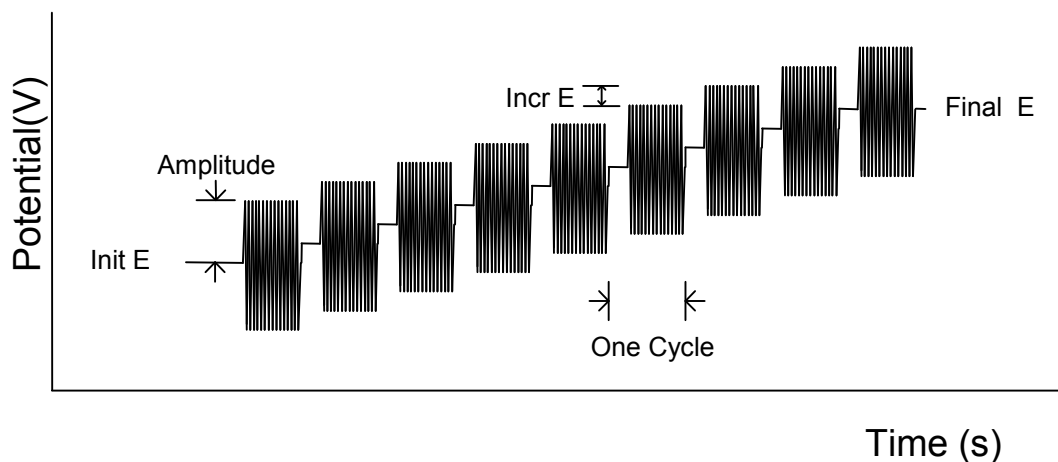

Parameter	Range	Description
Init E (V)	-10 - +10	Initial potential
Final E (V)	-10 - +10	Final potential
Incr E (V)	0.001 - 0.25	Increment potential
Amplitude (V)	0.001 - 1.5	A.C. amplitude
Frequency (Hz)	0.0001 - 1e5	A.C. frequency
Cycles (< 10 Hz)	1 - 100	Number of repetitive cycles at each frequency
Quiet Time (s)	0 - 100000	Quiescent time before sampling data
Bias DC Current	off - range - on	Enable DC current bias during run
Sensitivity Scale	1e-12 - 0.1	Sensitivity scale (automatic or manual)

Notes

- When DC current is high and AC current is low, sensitivity cannot be increased because the DC current will overflow. This problem is more serious when the frequency is relatively low. The application of a DC current bias allows higher AC signal amplification. A 16-bit DAC is used for this purpose. On the other hand, if the DC current is not expected to be large and the frequency is high, a DC current bias may be unnecessary.
- Automatic sensitivity scale is used by default. During the experiment, the system tests the current size and determines the proper sensitivity scale. This usually works pretty well. The sensitivity scale setting can also be manually overridden, which may yield better results in certain cases.

4.2.26 Chronopotentiometry Parameters dialog box

In Chronopotentiometry (CP), two current levels can be specified to pass through the working electrode, with the switching between the two dictated by time or potential. Potential is recorded as a function of time. The following diagram shows the current waveform applied as a function of time.

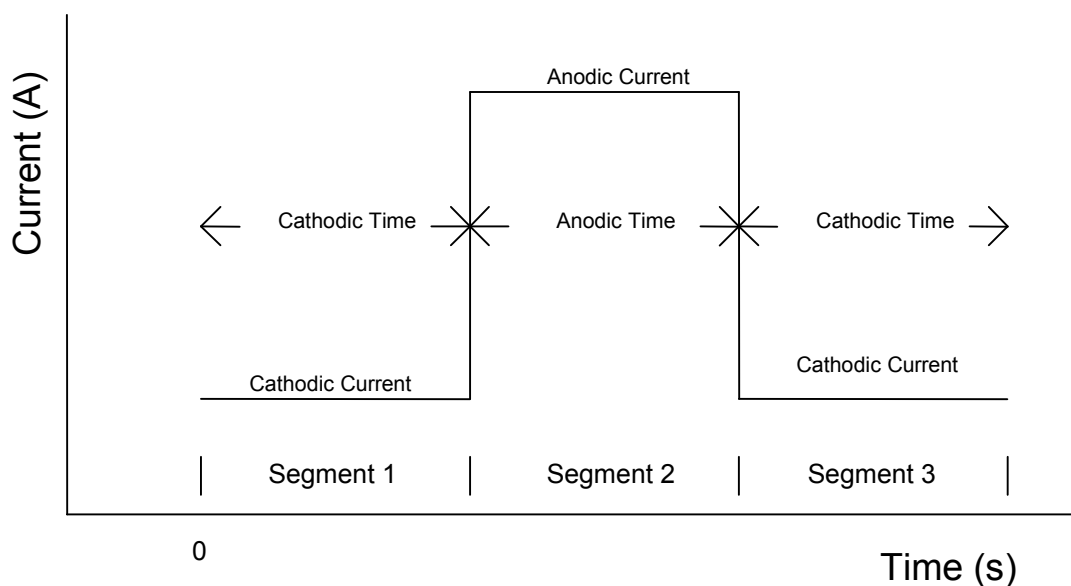

Parameter	Range	Description
Cathodic Curr. (A)	-2 - +2	Controlled cathodic current
Anodic Current (A)	-2 - +2	Controlled anodic current
High E Limit (V)	-10 - +10	High potential limit
High E Hold T. (s)	0 - 100000	High potential hold time
Low E Limit (V)	-10 - +10	Low potential limit
Low E Hold T. (s)	0 - 100000	Low potential hold time
Cathodic Time (s)	0.005 - 100000	Cathodic run time
Anodic Time (s)	0.005 - 100000	Anodic run time
Initial Polarity	Cathodic/Anodic	Polarity for the first segment
Data Stor. Intvl (s)	0.0001 - 500	Data storage interval
Num. of Segments	1 - 1000000	Number of half cycles
Curr. Switch. Prior.	Potential or Time	Current polarity switching control
Aux. Signal Rec.	Check or Uncheck	Simult. record external signal when samp. interval \geq 0.0005 s

Notes

- Cathodic and anodic currents correspond to reduction and oxidation, respectively. When the Low E limit is reached during reduction, the current polarity will automatically be switched to anodic. Similarly, when the High E Limit is reached during oxidation, current will automatically be switched to cathodic. When the number of current polarity switches (Segments) is reached, the experiment stops.
- The Initial Polarity parameter specifies the initial current polarity.
- During the experiment, data update and storage rates will be the same (i.e., dictated by the Data Storage Intvl parameter).
- The data sampling interval should be chosen according to the length of the experiment. The longer the experiment, the longer the sampling interval should be.
- During an experiment, whenever the data exceed the maximum allowed points, the data storage interval will be doubled automatically. Therefore, data points will not overflow for an unexpectedly long experiment.

- A large number of segments can be specified, but data will only be stored for the first 400 segments. Later segments will be displayed during the run but not stored.
- The current polarity can be switched when either the specified potential or the specified time has been reached. The switching time can be different for cathodic and anodic switching. Note, however, that even with Time switching selected, if the limiting potential is reached, the current polarity will still be reversed in order to protect the electrode.

4.2.27 Chronopotentiometry with Current Ramp Parameters dialog box

In the Chronopotentiometry with Current Ramp technique (CPCR), a current ramp is applied to the working electrode, and potential is recorded as a function of time. The following diagram shows the current waveform applied as a function of time.

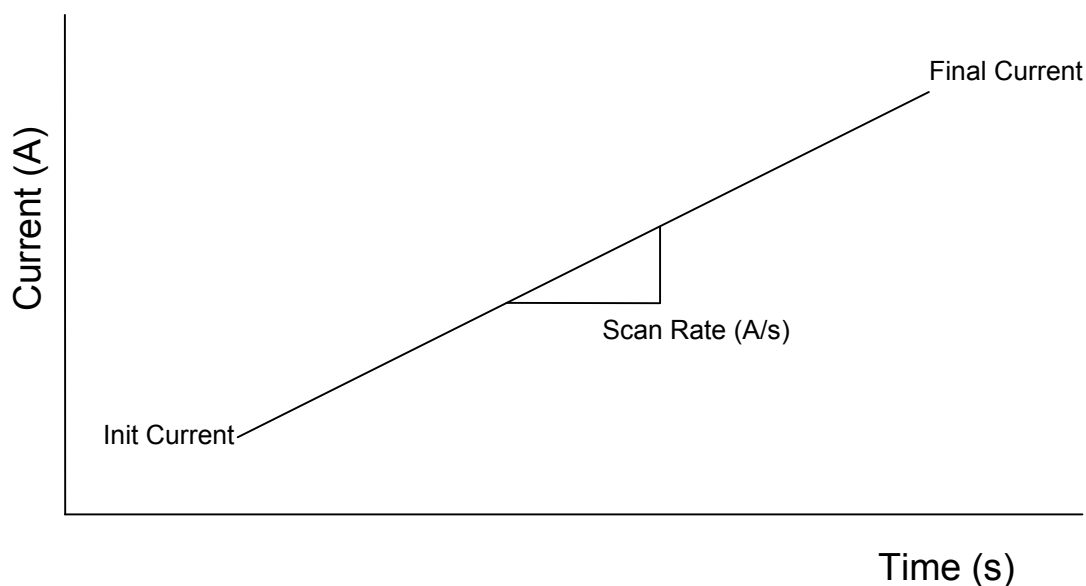

Parameter	Range	Description
Init Current (A)	-2 - +2	Controlled cathodic current
Final Current (A)	-2 - +2	Controlled anodic current
Scan Rate (A/s)	1e-12 - 0.1	Current scan rate
High E Limit (V)	-10 - +10	High potential limit
Low E Limit (V)	-10 - +10	Low potential limit
Data Stor. Intvl (s)	0.0001 - 500	Data storage interval

Notes

- Initial Current and Final Current should be at least 1e-9A apart.
- Cathodic and anodic currents correspond to reduction and oxidation, respectively. If the High E or Low E limit is reached during reduction, the experiment stops.
- At least 10 points are required to run the experiment. Reduce the current scan rate or reduce the sampling interval as needed to meet this requirement.
- During the experiment, data update and storage rates will be the same (i.e., dictated by the Data Storage Intvl parameter).
- The data sampling interval should be chosen according to the length of the experiment. The longer the experiment, the longer the sampling interval should be.
- During an experiment, whenever the data exceed the maximum allowed points, the data storage interval will be doubled automatically. Therefore, data points will not overflow for an unexpectedly long experiment.

4.2.28 Multi-Current Steps Parameters dialog box

In the Multi-Current Steps technique (ISTEP), up to twelve current steps can be applied and cycled. Potential is recorded as a function of time. The following diagram shows the current waveform applied as a function of time.

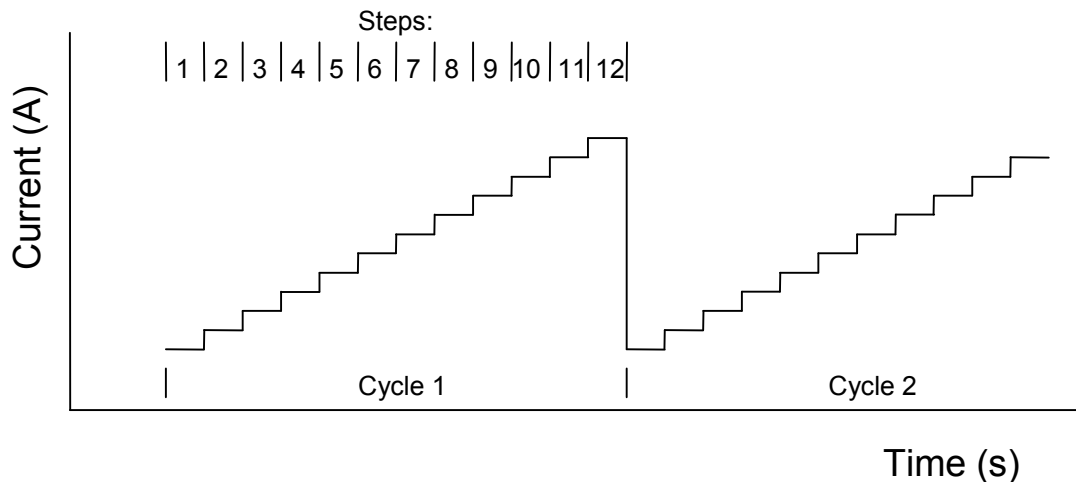

Parameter	Range	Description
Step Seq. 1-12		
Step i (A)	-2 - +2	Step current
Step Time (s)	0 - 10000	Step duration
High E Limit (V)	-10 - +10	High potential limit
Low E Limit (V)	-10 - +10	Low potential limit
No. of Cycles	1 - 10000	Number of cycles
Smpl Intv (s)	1e-5 - 1	Sampling interval

Notes

- A step with duration less than 0.001 sec or shorter than the sampling interval will be ignored.
- If the sampling interval is longer than 0.002 sec, data will be transferred and displayed in real time.
- The experiment will stop if the potential reaches either High E Limit or Low E Limit.
- The sampling interval will be automatically increased if (step time * cycles / sample interval) exceeds 128K if data is to be transferred after the experiment.

4.2.29 Potentiometric Stripping Analysis Parameters dialog box

In Potentiometric Stripping Analysis (PSA), a constant potential deposition step is first applied, after which the species accumulated at the electrode surface are stripped out by applying a constant current. Potential is recorded as a function of time. The following diagram shows the potential waveform during the deposition stage and the current waveform during the stripping stage.

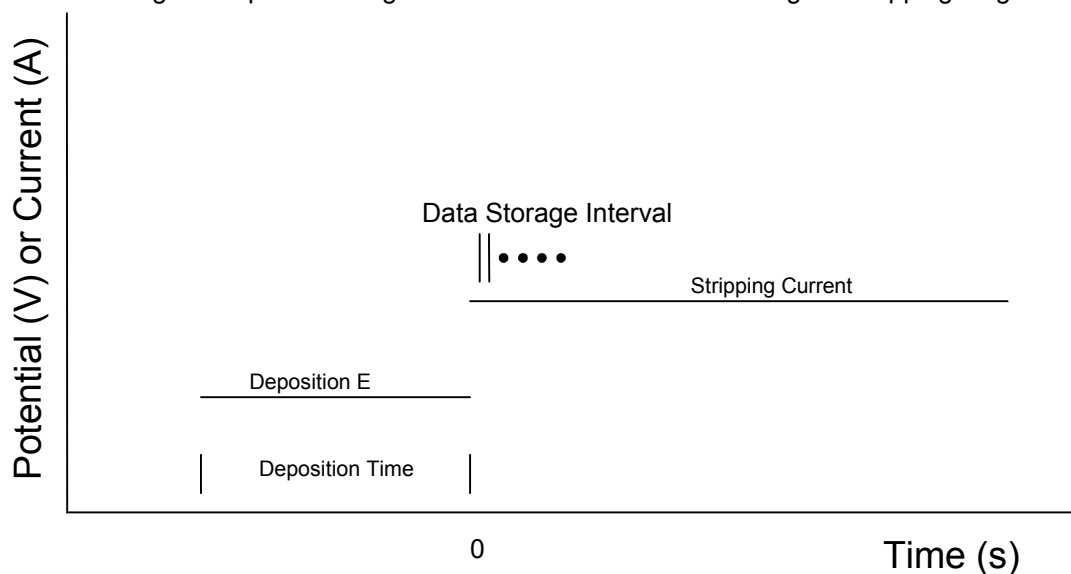

<i>Parameter</i>	<i>Range</i>	<i>Description</i>
Deposition E (V)	-10 - +10	Deposition potential
Deposit. Time (s)	0 - 1000000	Deposition time
Final E (V)	-10 - +10	Final potential (see Notes)
Stripping Curr. (A)	0 - 2	Controlled stripping current
Sample Interval (s)	0.0001 - 50	Sampling interval
Quiet Time (s)	0 - 100000	Quiescent time before taking data

Notes

- If sample interval is less than 0.002 s, a total of 64K data points is allowed. The data density is equal to Run Time / 64000.
- If the final potential is reached, the experiment will automatically stop.
- If the controlled stripping current is set to zero, the counter electrode is actually not connected.
- If the controlled stripping current is smaller than 1.0e-10A, no current will flow during experiment.
- You do not have to worry about the current polarity; the system will automatically assign the current polarity according to the deposition potential and the final potential. Positive and negative current correspond to reduction and oxidation, respectively.
- In general, the data storage interval should be chosen according to the length of the experiment. The longer the experiment, the longer the data storage interval should be.

4.2.30 Parameters for Electrochemical Noise Measurement dialog box

In Electrochemical Noise measurements (ECN), no waveform is applied to the electrochemical cell. The working electrode is at the zero-resistance ammeter, and its potential is at virtual ground (very close to ground; it cannot be connected to a true ground). To measure electrochemical noise, an electrode identical to the working electrode should be connected to the instrument ground (the black banana jack on the rear panel labeled GND), and both electrodes should be immersed in the same solution. The electrochemical noise current passing through these two electrodes will be measured. To measure potential noise, add a reference electrode to the solution and connected it to the reference clip. The counter electrode will not be used.

The system displays the following dialog box:

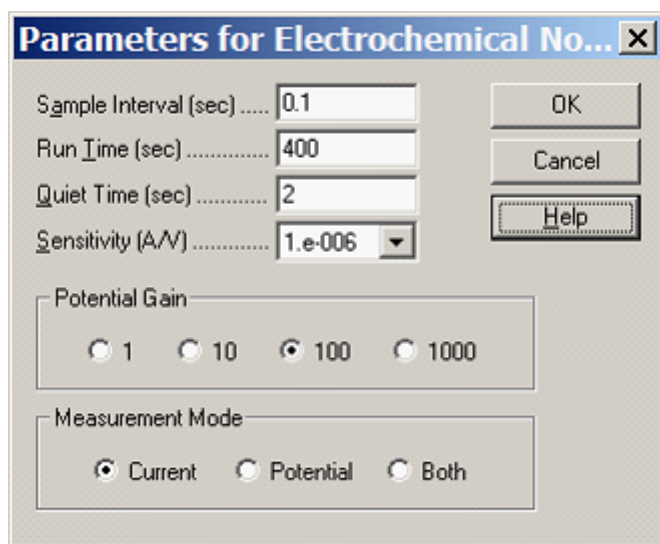

Parameter	Range	Description
Sample Interval (s)	0.1 - 10	Sampling interval
Run Time (s)	10 - 100000	Experiment running time
Quiet Time (s)	0 - 100000	Quiescent time before potential pulses begin
Sensitivity (A/V)	1e-9 - 0.1	Sensitivity scale
Potential Gain	1, 10, 100, 1000	Gain setting for potential noise measurement
Meas. Mode	i, E, or both	Measurement mode

4.2.31 Parameters for Open Circuit Potential vs Time dialog box

In the Open Circuit Potential - Time technique (OCPT), the working and reference electrodes are connected and the potential difference across them is recorded as a function of time. Since the counter electrode is not connected to the external cell, no current passes through the working electrode except the bias current of the measuring amplifiers, which is in the picoamperes range.

The program presents the following dialog box:

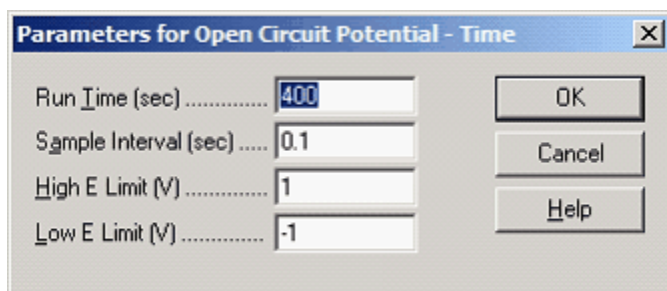

Parameter	Range	Description
Run Time (s)	1 - 500000	Experiment running time
Sample Interval (s)	0.0025 - 50	Sampling interval
High E Limit (V)	-10 - +10	High potential limit
Low E Limit (V)	-10 - +10	Low potential limit

Notes

- If the high or low potential limit is reached, a warning will be given.
- In general, the data storage interval should be chosen according to the length of the experiment. The longer the experiment, the larger the data storage interval.

4.3 System command

This command opens the System Setup dialog box.

Use this command to set up the serial communication port, current polarity, potential axis and current axis. You can choose any convention for the potential and current axis.

The System command presents this dialog box.

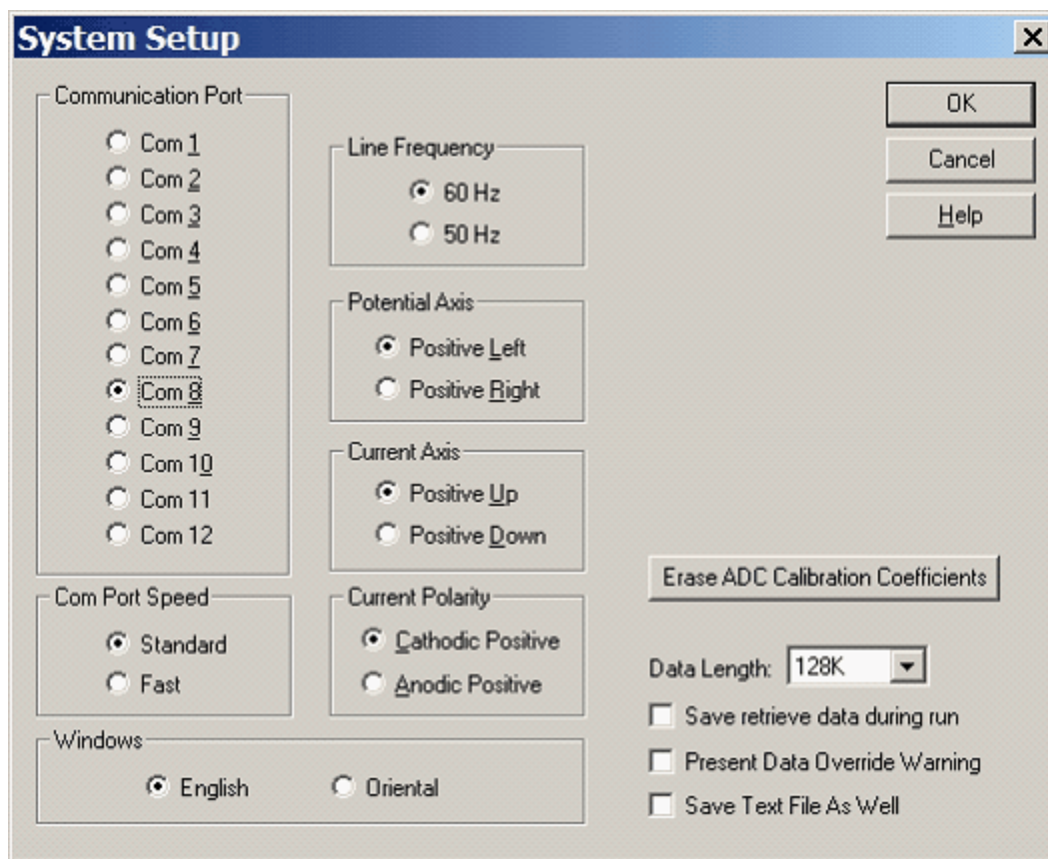

The following options allow you to set up your system:

Communication Port

Select the PC communication port to which the instrument is linked. Available ports should be listed in the Windows Device Manager.

Com Port Speed

Set the communication speed between the PC and the instrument. The Fast setting allows real time data transfer at higher scan rate and/or shorter sampling interval. The Standard setting is included for greater compatibility.

Current Polarity

Assign anodic or cathodic current as positive-valued. This sign convention must be chosen before running an experiment; otherwise, experimental results (peaks, waves) will not be reported properly.

Potential Axis

Assign left or right as the positive direction for the potential axis (only applicable to voltammetric or polarographic techniques).

Current Axis

Assign up or down as the positive direction for the current axis.

Line Frequency

Select the correct (power) line frequency for your geographic region. This will reduce interference from the line frequency by adjusting the default sampling interval in certain techniques.

Windows

Select the language used by your Windows operating system (Oriental covers Chinese, Japanese, and Korean Windows). The Technique selection field may be truncated if you select English Windows. Oriental Windows uses shows slightly bigger letters than English Windows, and does not support certain symbols. For instance, the symbol " μ " may not be displayed properly in Oriental Windows. When set to Oriental, the program will use "u" instead of " μ ".

Data Length (requires program restart)

The default data length is 128K. It is recommended not to use longer data length unless necessary. Using long data length will need large computer memory such as 256M, 512M RAM or more. Longer data length requires more computer resources, slows down your PC, and may prohibit other programs from running.

After changing this setting, please exit and restart the program; otherwise the program may crash.

If data is acquired and saved with a longer data length but read back with a shorter data length, the program may also crash. To prevent this, if the data length has been increased, it should not be decreased to a smaller value later. Please think carefully before you decide to increase the data length.

Save retrieve data during run

This option allows data to be saved on the PC hard drive during an experimental run. In case your experiment does not run to completion, e.g., due to external interference, interruption, or missed communication, data can be recovered partially. This is useful for very slow experiments; hours of experimental data can be recovered.

For performance reasons, this command is not enabled by default. If a fast experiment is accidentally interrupted, it may prove more expedient to simply re-run the experiment instead of using the Retrieve command, which is located under the File menu.

Present Data Override Warning

If your experimental data is not saved before running a new experiment or opening an existing file on the disk, your unsaved data will be overridden. This option will allow system to issue a warning before the data is lost.

Save Text File As Well

By default, the program only saves binary data files, which contain extra system information (including

experimental control information). This option allows you to save your data in text format as well whenever you save a binary data file. This is useful for exporting data to read into other software (e.g., spreadsheets).

Erase ADC Calibration Coefficients

The analog-to-digital converter (ADC) calibration coefficients are stored in the instrument's non-volatile memory. ADC calibration is carried out in the factory before the instrument is shipped. Use this command only if you want to recalibrate the ADC yourself. To do so, simply click this button, and the program will automatically prompt you to calibrate the ADC during the next hardware test or experiment.

4.4 Hardware Test command

Use this command to test the system hardware. The system will test digital and analog circuitry.

After the test, the system will display the test results in the Hardware Test Results dialog box.

The Self Test command tests the digital and analog circuitry in the instrument. This command presents the following dialog box:

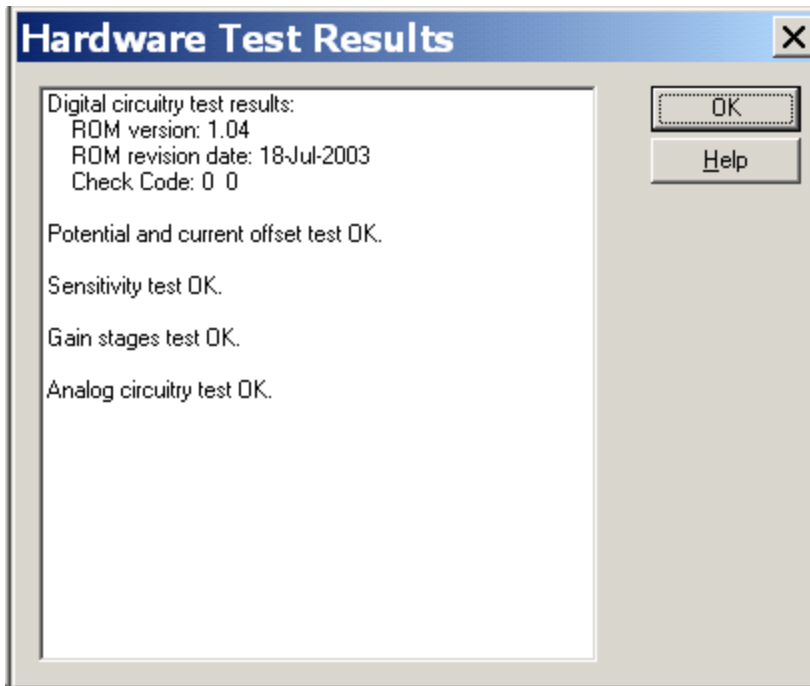

Review the Self Test results carefully. In the case of an analog test error, please repeat the test several times to see if the error is consistent. Record the error message and contact the factory for servicing.

Digital Circuitry Test Results

- Firmware version number and revision date
- ROM test result (if applicable)
- RAM test result (if applicable)

Potential and current offset test

If this test has been failed, an error message will be given.

Sensitivity scale test

If this test has been failed, an error message will be given. This error is usually is related to leakage current.

Gain test

If this test has been failed, an error message will be given. There are 3 gain stages.

Analog Test Summary

If no error has been detected, the message box will simply read "Analog circuitry test OK." Errors caused by the analog-to-digital converters will also be reported here.

In the case of an analog test error, please repeat the test several times to see if the error is consistent. Record the error message and contact the factory for servicing.

Chapter 5 Control Menu

The **Control** menu offers the following commands:

Run Experiment	Start running an experiment.
Pause / Resume	Pause or unpause an experiment.
Stop Run	Stop running an experiment.
Reverse Scan	Reverse potential scan direction (CV only)
Zero Current	Zero current
Zero Time	Zero time
Run Status	Set certain conditions for running an experiment.
Repetitive Runs	Run an experiment multiple times.
Multiplexer	Set options for multiplexer (sold separately)
Macro Command	Execute a series of commands (cf. batch file or shell script).
Open Circuit Potential	Measure the open circuit potential.
iR Compensation	Set and test iR compensation (select models only).
Filter Setting	Set potential and current filters.
Cell	Set and control the electrochemical cell.
Step Functions	Generate square waveform for cleaning, etc. (select models only).
Preconditioning	Condition working electrode before experiment.
Rotating Disk Electrode	Set rotating disk electrode control parameters (select models only).
Other	Set miscellaneous options (select models only).
Stripping Mode	Set stripping mode and conditions.
SECM Probe	Calibrate and control the SECM probe (900 series only).

5.1 Run Experiment command

Use this command to start running your experiment.

This command can also be used to skip Quiet Time, Deposition Time or Preconditioning and go to the next step.

Before each run, the program will first verify data link with the instrument before proceeding. The program will also verify the values of experimental parameters; if illegal values have been entered, the command will terminate and the program will issue an error message.

During most experiments, data can be displayed in real time. When the data acquisition speed exceeds the data transmission rate, the results will be displayed immediately following the experiment.

Graphics can be copied to the clipboard during the run. The experiment can be halted by invoking the Stop command.

This command has a toolbar button:



5.2 Pause / Resume command

Use this command to pause and unpause your experiment.

This command is unavailable for time-based techniques, e.g., CA, CC, BE, i-t, DPA, DDPA, TPA, IMP, IMP-t, CP, PSA.

This command has a toolbar button:



5.3 Stop Run command

Use this command to stop running your experiment.

This command can also be used to stop repetitive runs or macro commands. It has a toolbar button:



5.4 Reverse Scan command

Use this command to reverse the potential scan direction during a cyclic voltammetry experiment.

Each time this command is invoked, the sweep segment counter increments.

If this command is used during an experiment, certain data analysis features will be unavailable, e.g., peak search.

This command has no effect for other techniques. It has a toolbar button:



5.5 Zero Current command

During an Amperometric i-t Curve experiment, the Zero Current command will manually bias the current to zero, to facilitate current reading after the baseline has settled. This is particularly useful for electrochemical detection.

This command can only be used while an Amperometric i-t Curve experiment is in progress, and it cannot be used for other techniques. It has a toolbar button:



5.6 Zero Time command

During an Amperometric i-t Curve experiment, the Zero Time command set the time to zero, throwing away all previous data points. This command can facilitate the time reading and reduce the number of unusable data points, and is particularly useful for electrochemical detection.

This command can only be used while an Amperometric i-t Curve experiment is in progress, and it cannot be used for other techniques.

5.7 Run Status command

This command opens the Run Status dialog box.

Use this command to adjust certain options related to the currently running experiment, including iR compensation, automatic smoothing, purge, stir, and prerun mercury drops.

The Run Status command presents this dialog box.

Calibration Before Run

When this box is checked, the potential and current offsets will be measured and compensated before running the experiment. Disable this option to allow the experiment to start faster.

Check Connection Before Run

When this box is checked, the program will verify that the counter and reference electrodes are connected before running the experiment. If one of the electrodes is not connected, a warning message will appear; proceed with the experiment at your own caution. This option can prevent accidental damage to the working electrode due to an open loop. Disable this option to allow the experiment to start faster.

Use Open Circuit E as Init E

When this box is checked, the program will measure the open circuit potential before running the experiment and use this value as the initial potential.

External Trigger Run

When this box is checked, the experiment will be initiated by an external trigger signal from the Cell Control port on the rear panel. Consult the appendix of the user manual for pin assignments.

iR Comp for Next Run

When this box is checked, iR compensation will be enabled for the next run. You may be unable to enable iR compensation if automatic compensation has been set but the iR compensation test has not been conducted, or if the sensitivity scale has been altered. iR compensation is not available for certain techniques, such as TAFEL, BE, IMP, CP, and PSA. This option can also be turned on or off from the iR Compensation command under the Control menu.

Smooth After Run

When this box is checked, automatic smoothing will be performed after the run. Certain techniques, such as TAFEL, BE and IMP, do not allow smoothing. This option can also be turned on or off using the Smoothing command under the DataProc menu, where the mode of smoothing can be set to least square or Fourier transform.

Purge Between Runs

Check this box to enable purging between runs.

Stir Between Runs

Check this box to enable stirring between runs.

SMDE Drops Before Run

When using the static mercury drop electrode (SMDE), specify the number of mercury drops to be dispensed before the experiment. Normally the system will issue a combined dispense and knock signal before running the experiment to allow a new drop to be formed.

This parameter should be between 0-20 (default 1); if set to 0, the same drop used in the previous experiment will be used for the next experiment. It may be useful to use more than one prerun drop if the SMDE occasionally traps little air bubbles in the capillary and loses contact.

This option can also be varied using the Cell command under the Control menu.

E2 off During Quiet Time (if applicable)

Not applicable for your instrument series.

Abort Experiment at Level

The experiment will terminate automatically if the current or charge level reaches the specified value (or overflows). This allows electrode over-current protection.

If "No" is selected, the experiment will end normally.

If "10s Change <" is selected, the experiment will terminate automatically if the signal change after 10 seconds is less than the specified value (in Amperes for current and Volts for potential). This option is applicable only for time-based techniques, such as CA, IT, DPA, DDPA, and TPA.

The program does not monitor the signal change during the first 10 seconds of the experiment. After

that, the program checks every time it samples. The response time is equal to the sampling interval. After data is read, the program compare with the data point sampled 10 seconds ago and the difference will be checked. If the difference is less than the specified value, the experiment will terminate.

Abort Quiet Time

The quiet time before data acquisition will terminate automatically if the current or charge level reaches the specified value (or overflows). If "No" is selected, the experiment will end normally.

Current Display during Quiet Time

Specify whether the current during quiet time is displayed numerically, graphically, or not at all. The sensitivity scale will be automatically adjusted in order to read the current properly. If "No" is selected, the current will not be displayed during quiet time, and the sensitivity will be the same as that used in the experiment.

5.8 Repetitive Runs command

This command opens the Repetitive Run dialog box.

Use this command to run an experiment multiple times. Before each run, the program will first verify data link with the instrument, aborting the series of runs if link fails. The program will also verify the values of experimental parameters; if illegal values have been entered, the command will terminate and the program will issue an error message.

The Repetitive Runs command opens this dialog box.

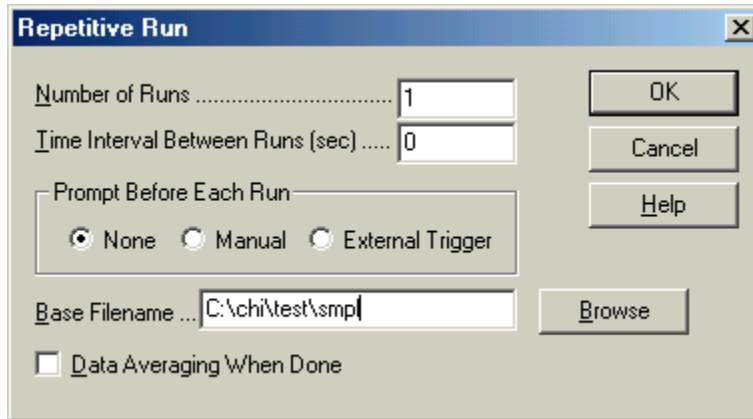

Number of Runs

Enter the number of runs; the parameter range is 1 - 9999.

Time Interval Between Runs

Specify the time delay between two successive runs; the parameter range is 0 - 32767. This parameter is ignored if Prompt Before Each Run is enabled.

Prompt Before Each Run

If Manual is selected, you will have to click on a message box before each run (except the 1st run). The instrument will wait until you respond.

If External Trigger is selected, the instrument will wait for an external trigger signal before each run. The trigger signal is an active low signal and can be applied to Pin 13 of the Cell Control port on the rear panel.

When Manual or External Trigger is selected, the Time Interval Between Runs parameter is ignored.

Base Filename

Click Browse or type directly in this field to specify the filename prefix (up to 5 characters). Data will be saved after each run. The run number will be attached to the base filename, i.e., filenameN, where N is the run number. If a base filename is not specified, a warning will be given. If you continue, the system will run the experiments without saving any data.

Data Averaging When Done

When this item is checked, the data of the repetitive runs will be averaged and saved as filename0.

5.9 Multiplexer command

This command opens the Multiplexer dialog box.

Use this command to run a series of experiments using the CHI684 Multiplexer (sold separately). The multiplexer switches four lines (working, sensing, reference, and counter for a single potentiostat, second working, reference and counter for a bipotentiostat). You can have up to 64 cells, but only one cell can be connected at a time. The minimum number of channels for the CHI684 is 8. The channel increment is 8. The maximum number of channels is 64.

The Multiplexer command presents this dialog box.

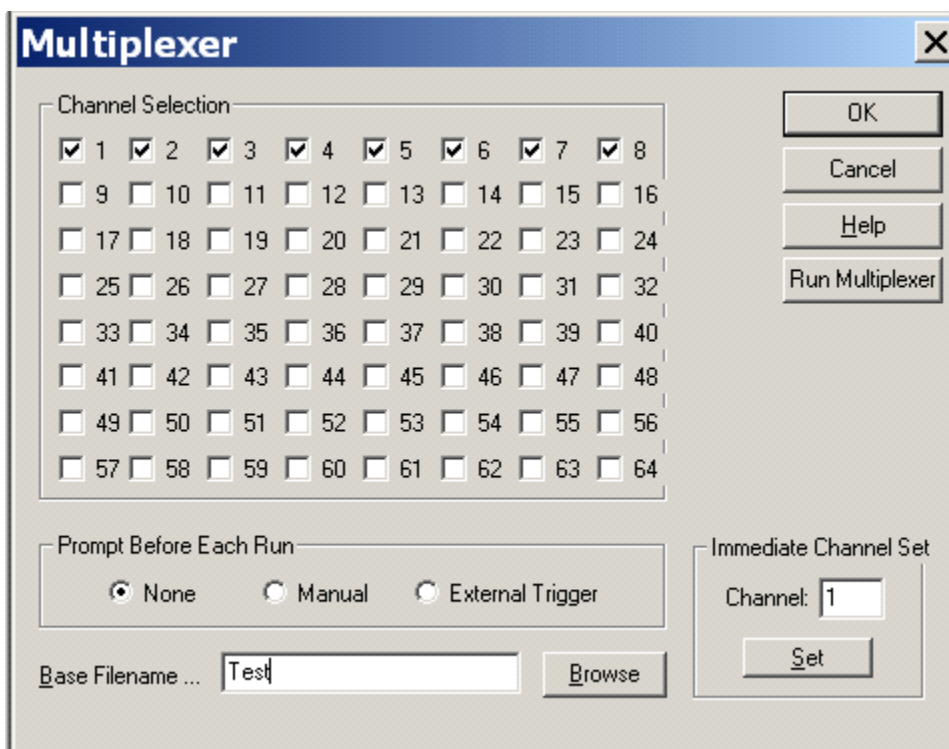

Channel Selection

Click a channel to enable it and uncheck to disable. If you select a channel beyond your CHI684 channel number, it will be ignored.

Prompt Before Each Run

If Manual is selected, you will have to click on a message box before each run (except the 1st run). The instrument will wait until you respond.

If External Trigger is selected, the instrument will wait for an external trigger signal before each run. The trigger signal is an active low signal and can be applied to Pin 13 of the Cell Control port on the rear panel.

Base Filename

Click Browse or type directly in this field to specify the filename prefix (up to 5 characters). Data will be saved after each run. The run number will be attached to the base filename, i.e., filenameN, where N

is the channel number. For instance, if you set base filename as "test", and you select channels 3, 8, 23, and 58, Run Multiplexer will run 4 experiments and save data as test3.bin, test8.bin, test23.bin, and test58.bin. If a base filename is not specified, a warning will be given. If you continue, the system will run the experiments without saving any data.

Before execution, the program will check for existing data files with a same base filename, issuing an overwrite warning if found.

Immediate Channel Set

This allows you to select an arbitrary channel immediately. You can then exit the dialog box and run an experiment for that particular channel.

Run Multiplexer

Click this button to run experiments for the selected channels using the CHI684 Multiplexer. Experimental conditions should be set before this command is executed.

Side Note: Multiplexer-Related Macro Commands

Two Macro commands are available for the CHI684 multiplexer.

The macro command "mch:##" allows you to select an individual channel.

The macro command "mchn" is used in For loops to select the channel given by the For loop counter. Note that this macro command will run in 1,2,3,4... sequence; you cannot skip channels in a For loop.

5.10 Macro Command command

This command opens the Macro Command dialog box.

Use this command to execute a series of other commands. This is analogous to batch files in Windows or shell scripts in Unix/Linux and is much more flexible than the Repetitive Runs command.

The Macro Command command presents this dialog box.

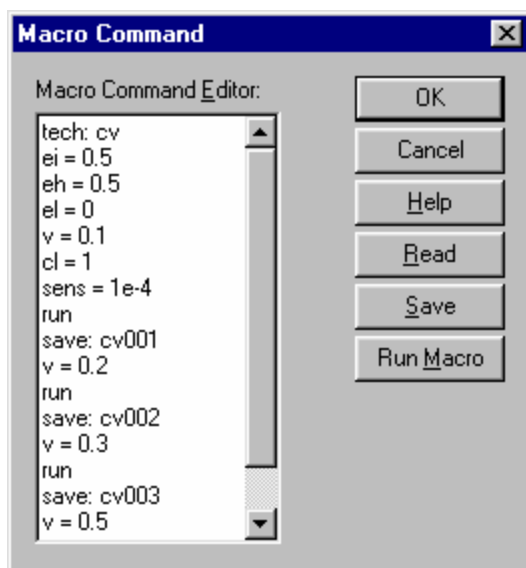

Read

Load macro from file. The program displays the Open dialog box so you can select your file.

Save

Save macro to file for later use. The program displays the Save As dialog box so you can name your file.

Run Macro

Click this button to execute the macro. The system will verify the commands and parameter ranges of your macro before proceeding.

Macro Command Editor

Type in the desired series of commands in the editor box. Each command occupies one line. The command is case insensitive. Space will be ignored. If a parameter is required following the command, a colon ":" or an equal sign "=" is used to separate the command and parameter.

Legal Commands (common)

Command	Parameter	Explanation
tech	string	select an electrochemical technique
folder	string	specify where to save files: e.g., c:\ch\test

run		run experiment
save	string	save data to file; when used in for...next loop, filename will be truncated to 5 letters and loop number (1-999) will be added to filename
tsave	string	save data as text file
fileoverride		allow file override without warning
macrotest		check macro without execution
end		end of macro; lines below will be ignored
beep		sound notification
for	1 - 999	for...next loop; only one layer is allowed
next		end of for...next loop
delay	1 - 32000	delay between commands
purge	1 - 32000	purge for specified time
stir	1 - 32000	stir for specified time
trigon		turn on trigger before run
trigoff		turn on trigger before run
knockon		turn on drop knocker; also used to send trigger pulse to external device before run
knockoff		turn off drop knocker; no pulse before run
qcmmon		QCM mode on
qcmoff		QCM mode off
auxon		turn on auxiliary signal recording channel
auxoff		turn off auxiliary signal recording channel
cellon		cell on between runs
celloff		cell off between runs
rdeon		turn on RDE
rdeoff		turn off RDE
rdedepositionon		RDE on during deposition
rdedepositionoff		RDE off during deposition
rdequieton		RDE on during quiet time
rdequietoff		RDE off during quiet time
rderunon		RDE on during run
rderunoff		RDE off during run
rdebetweenrunon		RDE on between runs
rdebetweenrunoff		RDE off between runs
rpm	0 - 10000	RDE rotation rate in rpm
rpmincr	0 - 1000	RDE rotation rate increment in rpm

rpmsqrt	0 - 100	square root of rotation rate
rpmsqrtincr	0 - 10	square root of rotation rate increment
aflt		automatic filter setting
flt1	0 - 8	potential filter: 0=none, 1=150KHz, 2=15KHz, ...
flt2	0 - 7	i/V converter: 0=none, 1=32kHz, 2=3.2kHz, ...
flt3	0 - 8	signal filter: 0=none, 1=150KHz, 2=15KHz, ...
flt4	0 - 7	2nd channel i/V: 0=none, 1=32kHz, 2=3.2kHz, ...
flt5	0 - 8	2nd channel signal filter: 0=none, 1=150KHz, ...
mch	1 - 64	select multiplexer channel
mchn		multi. channel selection according to for/next loop
ei	-10 - +10	initial potential
eh	-10 - +10	high limit of potential in CV, CA, CP
el	-10 - +10	low limit of potential in CV, CA, CP
ef	-10 - +10	final potential for single sweep tech and PSA
eio		use open circuit potential (OCP) as init E; disabled after new init E is specified by ei
eho		use OCP as high E; disabled by eh command
elo		use OCP as low E; disabled by el command
efo		use OCP as final E; disabled by ef command
eioei	-10 - +10	use OCP + this value as init E; disabled by ei
eioef	-10 - +10	use OCP + this value as final E; disabled by ei
eiocenter		use OCP as center potential; shifts high and low E limits on both sides of OCP
eiincr	-1 - +1	increment init E in for...next loop; should be reset to zero after loop
efincr	-1 - +1	increment final E in for...next loop; should be reset to zero after loop
ehincr	-1 - +1	increment high E in for...next loop; should be reset to zero after loop
elincr	-1 - +1	increment low E in for...next loop; should be reset to zero after loop
fullcycleon		CV full cycle on
fullcycleoff		CV full cycle off
efon		Final E on
efoff		Final E off
sens	1e-12 - .1	sensitivity scale
sens2	1e-12 - .1	sensitivity for 2nd working electrode if applicable

autosens		automatic sensitivity if applicable
qt	0 - 100000	quiescent time before run if applicable
ht	0 - 100000	hold time at final E if applicable
smodeon		turn on stripping mode
smodeoff		turn off stripping mode
depeon		turn on deposition potential in stripping mode
depeoff		turn off deposition potential in stripping mode
depe	-10 - +10	deposition potential
dept	1 - 100000	deposition time in seconds
quieteon		turn on quiet potential in stripping mode
quieteoff		turn off quiet potential in stripping mode
quiete	-10 - +10	quiescent potential in stripping mode
pcon		turn on preconditioning
pcoff		turn off preconditioning
pcon2		turn on preconditioning for channel 2
pcoff2		turn off preconditioning for channel 2
initeon		return to initial potential after run
initeoff		remain at final potential after run
pce1	-10 - +10	potential for 1st stage of preconditioning
pce2	-10 - +10	potential for 2nd stage of preconditioning
pce3	-10 - +10	potential for 3rd stage of preconditioning
pct1	0 - 6400	time for 1st stage of preconditioning
pct2	0 - 6400	time for 2nd stage of preconditioning
pct3	0 - 6400	time for 3rd stage of preconditioning
noabort		do not abort experiment during run
abortov		abort experiment if current overflow
abortigt	0 - 2	abort experiment if current > specified value
abortilt	0 - 2	abort experiment if current < specified value
abortq	0 - 100000	abort experiment if charge > specified value
abort10s	0 - 1	abort experiment if signal change in 10 seconds is less than specified value
abortchgt	1 - 3600	revise abort10s to specified time interval
bce1a	-10 - +10	Baseline Correction (BC; a.k.a. baseline fitting and subtraction): 1st peak foot "from" potential
bce1b	-10 - +10	BC: 1st peak foot "to" potential
bce2a	-10 - +10	BC: 2nd peak foot "from" potential
bce2b	-10 - +10	BC: 2nd peak foot "to" potential

bce3a	-10 - +10	BC: 3rd peak foot "from" potential
bce3b	-10 - +10	BC: 3rd peak foot "to" potential
bce4a	-10 - +10	BC: 4th peak foot "from" potential
bce4b	-10 - +10	BC: 4th peak foot "to" potential
bce5a	-10 - +10	BC: 5th peak foot "from" potential
bce5b	-10 - +10	BC: 5th peak foot "to" potential
bcorder	1 - 19	BC polynomial order
bcalgor	0 - 1	BC algorithm: 0=orthogonal, 1=least squares
note	string	specify note field
header	string	specify header field in plot

Legal Commands (bipotentiostat only)

Command	Parameter	Explanation
e2on		turn on 2nd working electrode (no data recording)
e2off		turn off 2nd working electrode
i2on		turn on 2nd working electrode and record data
i2off		turn off 2nd working electrode
e2	-10 - +10	initial potential for channel 2
e2scan		2nd channel scan or step w/ primary channel
e2d		constant potential difference between 2nd and primary channel during potential scan or step
e2dscan		enable 2nd channel potential scan w/ primary channel but keep constant potential difference

Legal Commands (multipotentiostat only)

Command	Parameter	Explanation
ei	-10 - +10	initial potential for channel 1
e2	-10 - +10	potential for channel 2
e3	-10 - +10	potential for channel 3
e4	-10 - +10	potential for channel 4
e5	-10 - +10	potential for channel 5
e6	-10 - +10	potential for channel 6
e7	-10 - +10	potential for channel 7
e8	-10 - +10	potential for channel 8
sens	1e-9 - 1e-3	sensitivity scale for channel 1
sens2	1e-9 - 1e-3	sensitivity scale for channel 2
sens3	1e-9 - 1e-3	sensitivity scale for channel 3

sens4	1e-9 - 1e-3	sensitivity scale for channel 4
sens5	1e-9 - 1e-3	sensitivity scale for channel 5
sens6	1e-9 - 1e-3	sensitivity scale for channel 6
sens7	1e-9 - 1e-3	sensitivity scale for channel 7
sens8	1e-9 - 1e-3	sensitivity scale for channel 8
e1on		turn on channel 1
e2on		turn on channel 2
e3on		turn on channel 3
e4on		turn on channel 4
e5on		turn on channel 5
e6on		turn on channel 6
e7on		turn on channel 7
e8on		turn on channel 8
e1off		turn off channel 1
e2off		turn off channel 2
e3off		turn off channel 3
e4off		turn off channel 4
e5off		turn off channel 5
e6off		turn off channel 6
e7off		turn off channel 7
e8off		turn off channel 8
e2scan		scan or step channel 2 with primary channel
e3scan		scan or step channel 3 with primary channel
e4scan		scan or step channel 4 with primary channel
e5scan		scan or step channel 5 with primary channel
e6scan		scan or step channel 6 with primary channel
e7scan		scan or step channel 7 with primary channel
e8scan		scan or step channel 8 with primary channel
eiincr	-1 - +1	increment e1 in for...next loop; should be reset to zero after loop
e2incr	-1 - +1	increment e2 in for loop; should be reset to 0 after
e3incr	-1 - +1	increment e3 in for loop; should be reset to 0 after
e4incr	-1 - +1	increment e4 in for loop; should be reset to 0 after
e5incr	-1 - +1	increment e5 in for loop; should be reset to 0 after

e6incr	-1 - +1	increment e6 in for loop; should be reset to 0 after
e7incr	-1 - +1	increment e7 in for loop; should be reset to 0 after
e8incr	-1 - +1	increment e8 in for loop; should be reset to 0 after
sequential		sequential measurements
simultaneous		simultaneous measurements
indcell		independent cell
onecell		single cell with common reference and counter

For a complete list of technique-specific macro commands, please consult your .chm or .hlp help file.

5.11 Open Circuit Potential command

Use this command to measure the open circuit potential.

The open circuit potential is the potential between the working electrode and reference electrode while no current is flowing through the cell. This is an important parameter. It gives you information about the initial conditions before you start the experiment. You can then figure out if the compound under study is oxidizable or reducible.

After the measurement, the program will display the open circuit potential value through the Open Circuit Potential dialog box.

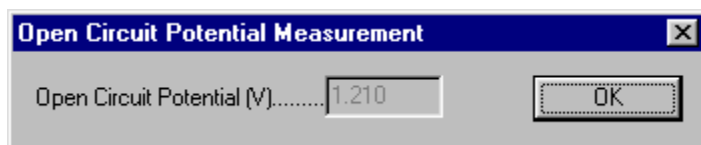

5.12 iR Compensation command

This command opens the iR Compensation dialog box.

Use this command to test the solution resistance and cell time constant, as well as switch between automatic or manual iR compensation.

This command has a toolbar button:



The iR Compensation command presents this dialog box.

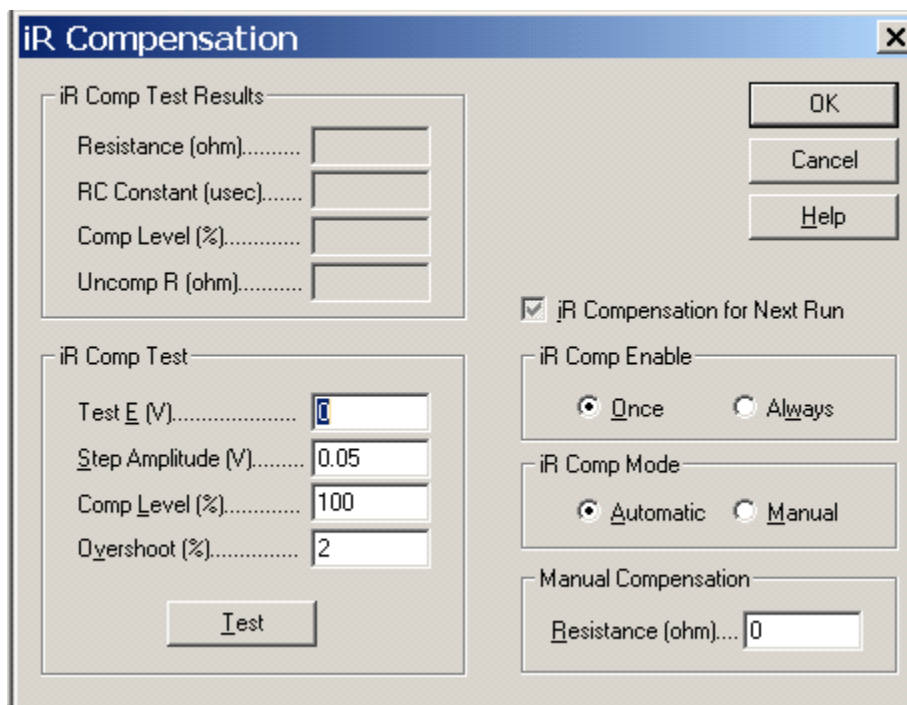

iR Comp Test Results

Click the Test button to execute the solution resistance and cell time constant test. The result will be reported here.

After that the program will test stability by gradually increasing the compensation level until the desired compensation level is reached or the system is no longer stable. The allowed compensation level and uncompensated resistance will be displayed. The uncompensated resistance is calculated from the measured resistance and the allowed compensation level.

Please note that the maximum allowed resistance and compensation may be limited to the feedback resistor of the i/E converter.

iR Comp Test

Before starting the iR compensation test, these test parameters must be specified correctly.

Test E is the test potential at which no electrochemical reaction will occur. When the system is performing the test, it applies a potential step relative to the test potential. The test is passed only if the

electrochemical cell can be considered equivalent to a solution resistance in series with a double layer capacitor. The allowed range of the Test E parameter is -10V to +10V.

Step Amplitude refers to the magnitude of the applied potential step. The larger the amplitude, the higher the signal-to-noise ratio. However, too large of an amplitude may cause faradaic current to flow. A step amplitude of 0.05V is recommended. The allowed range of the Step Amplitude parameter is 0.01V to 0.25 V.

The compensation level (Comp Level) is the percentage of resistance you want to compensate based on the measured solution resistance. The allowed range of this parameter is 0% to 200% (default 100%).

Overshoot level is the criterion of the stability test. As the amount of positive feedback increases, the system might become unstable. Before the potentiostat starts to oscillate, an overshoot in current in response to the potential pulse will be observed. The higher the allowed overshoot level, the higher the possible compensation level, but the worse the system stability. The range of this parameter is 0 - 100%. The default level is 2%.

Click the Test button to perform the solution resistance and stability test. The result will be reported in the iR Comp Test Results Box.

For more details about iR compensation, please refer to "Intelligent, Automatic Compensation of Solution Resistance", P. He, and L. R. Faulkner, *Anal. Chem.*, 58, 517-523 (1986).

iR Compensation for Next Run

When this box is checked, iR compensation will be enabled for the next run. You may be unable to enable iR compensation if automatic compensation has been set but the iR compensation test has not been conducted, or if the sensitivity scale has been altered. This option can also be turned on or off from the Run Status command under the Control menu.

iR Comp Enable

If the "Once" option is selected, iR compensation will be applied only to the next run and subsequently disabled. If you want the same compensation conditions to be applied to consecutive runs, select the "Always" option.

iR Comp Mode

Specify the mode of iR compensation. Automatic iR compensation will be based on the iR compensation test results. Manual iR compensation uses the resistance value you specify in the Resistance field below.

Manual Compensation Resistance

Specify the resistance value that you want system to compensate; this value is used only for manual iR compensation. Choose this value with care; if the compensation level is close to or exceeds the actual solution resistance, the potentiostat will oscillate. Please also notice that the maximum allowed resistance compensation may be limited to the feedback resistor of the i/E converter.

This parameter will be ignored if automatic iR compensation is selected.

5.13 Filter Setting command

This command opens a Filter Selection dialog box. Use this command to set potential and current filters.

The potential filter is used to filter the potential waveforms. It is a second-order Bessel low-pass filter and can be used to filter out transient components. The potential filter can be used, for instance, to convert a staircase ramp to a linear sweep.

A capacitor can be connected to the feedback resistor of the i/E converter to form a low-pass RC filter. This can remove the high-frequency noise at the first hand.

The signal filter is applied before the gain stage. It is a second-order Bessel low-pass filter.

These filters are useful for reducing the amount of noise during measurements.

Click the Help button in the resulting dialog box for more information.

This command has a toolbar button:



The Filter Setting command presents this dialog box.

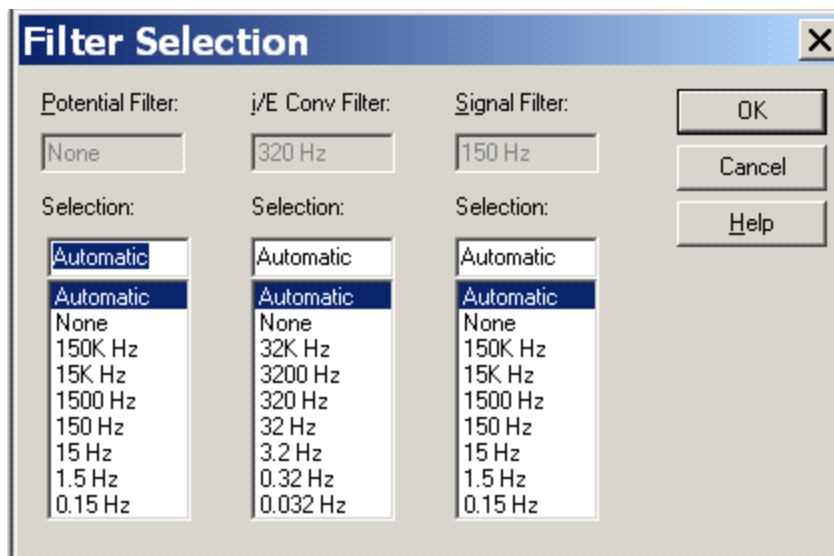

If you are unsure what settings to choose, please select "Automatic".

Potential Filter

The grayed-out box displays the actual potential filter setting. Choose the potential filter cutoff frequency from the list.

The potential filter is a 2nd order Bessel filter used to shape the waveforms. The appropriate setting for this filter should take the type and time scale of the experiment into account. For instance, the Automatic setting will filter out high frequency components to avoid aliasing in AC impedance measurements, whereas in linear sweep voltammetry it will convert the staircase ramp to a true linear potential sweep.

i/E Conv Filter

The grayed-out box displays the actual current-to-voltage converter filter setting. Choose the i/E converter filter cutoff frequency from the list.

The i/E converter filter is an RC filter in conjunction with the current-to-voltage (i/E) converter. The appropriate setting for this filter should take the type and time scale of the experiment into account.

In certain cases, some cutoff frequencies cannot be selected. This is because for a given sensitivity scale, the feedback resistor of i/E converter is fixed, and when this is combined with the RC filter, it may be impossible to reach certain cutoff frequencies. For instance, a low (high) sensitivity scale could preclude the selection of a relatively low (high) cutoff frequency. You may be able to select the desired cutoff frequency by altering the sensitivity scale.

Signal Filter

The grayed-out box displays the actual signal filter setting. Choose the signal filter cutoff frequency from the list. The signal filter is a 2nd order Bessel filter. The appropriate setting for this filter should take the type and time scale of the experiment into account.

5.14 Cell command

This command opens a Cell Control dialog box.

Use this command to control purge, stir, and electrochemical cleaning settings. You can also set the signal level of the stir line, mercury drop collection, prerun drops, and stabilizing capacitor.

Click the Help button of the resulting dialog box for more information.

This command has a toolbar button:



The Cell command presents this dialog box.

Control Level of Stir Line

The stir line control signal can be specified as active high (BAS) or active low (PAR).

Immediate Stir

Specify the immediate stir time (from 1 - 32767). Click the Stir button to activate immediate stirring.

Immediate Purge

Specify the immediate purge time (from 1 - 32767). Click the Purge button to activate immediate purging.

Immediate Cell On

Specify the cell potential (from -10 to +10) and the cell on time (from 1 to 32767). Click the Cell On button to poise the electrode at this potential for the specified amount of time.

SMDE Drops Before Run

When using the static mercury drop electrode (SMDE), specify the number of mercury drops to be dispensed before the experiment. Normally the system will issue a combined dispense and knock signal before running the experiment to allow a new drop to be formed.

This parameter should be between 0-20 (default 1); if set to 0, the same drop used in the previous experiment will be used for the next experiment. It may be useful to use more than one prerun drop if the SMDE occasionally traps little air bubbles in the capillary and loses contact.

Stabilizing Capacitor

There is a 0.1 μF stabilizing capacitor that can be connected between the counter and reference electrodes. This capacitor can stabilize the potentiostat but slows the system down somewhat. This is particularly useful when the double layer capacitance of the working electrode is large, such as in bulk electrolysis, or when a high degree of iR compensation is required.

When the Automatic Setting box is checked (default), the system will manage the stabilizing capacitor without user intervention; uncheck this box to manage the stabilizing capacitor manually with the radio buttons in this section.

Mercury Drop Collection

This useful option allows you to collect and weigh mercury drops. Specify the number of drops you want to collect (from 1 to 1000) and the time interval between drops (from 0.5 to 10), and click the Collect button to activate the collection process.

4 Electrodes

Check this box to set the potentiostat in 4-electrode mode.

The 4th electrode is used for sensing the voltage drop due to the contact resistance of the electrode clip, connector, relay, and circuit board traces. The contact resistance can be about 0.2 - 0.3 ohm and can cause a 50 - 75 mV voltage drop if the current is 250 mA, making low impedance cell measurements impossible (e.g., battery). With the addition of the 4th electrode, the effect of contact resistance can be eliminated, and low impedance cells can be readily measured.

The 4th electrode can also be used for liquid/liquid interface measurements. In the first liquid phase, the red clip is connected to the counter electrode and the white clip is connected to the reference electrode. In the second liquid phase, the green clip is connected to the counter electrode and the black clip is connected to the reference electrode.

You should turn the 4th electrode off if you do not use a 4-electrode configuration. Otherwise the potential will be out of control if the sensing electrode is left unconnected, which could damage the electrodes.

Purge Between Runs

Check this box to enable purging between runs. This option can also be turned on or off using the Run Status command under the Control menu.

Stir Between Runs

Check this box to enable stirring between runs. This option can also be turned on or off using the Run Status command under the Control menu.

Stir and Purge Simultaneously

Check this box to stir and purge at the same time.

Test with Internal Dummy Cell

Check this box to run the experiment with the instrument's internal dummy cell (a built-in 1K ohm resistor) instead of an external cell, which can be useful for testing the instrument.

Cell On Between Runs

Normally, the cell will be turned on only during an experiment and turned off after the experiment ends. Check this box to keep the cell connected after a run. Be careful when this option is enabled. Connecting or disconnecting the cell in an improper sequence can damage the electrodes when the cell is on. You should connect the reference and counter electrodes first. When disconnecting, disconnect the working electrode first.

Return to Initial E after Run

Check this box to set the potential back to the Initial E value after a run; otherwise, the potential will remain at the final value of the previous run. It only makes sense to enable this option if Cell On Between Runs is also checked.

5.15 Step Functions command

This command opens the Step Functions dialog box.

Use this command to generate a continuous square waveform for electrode conditioning, cleaning, or other purposes. No data will be collected and displayed.

The Step Functions command presents this dialog box.

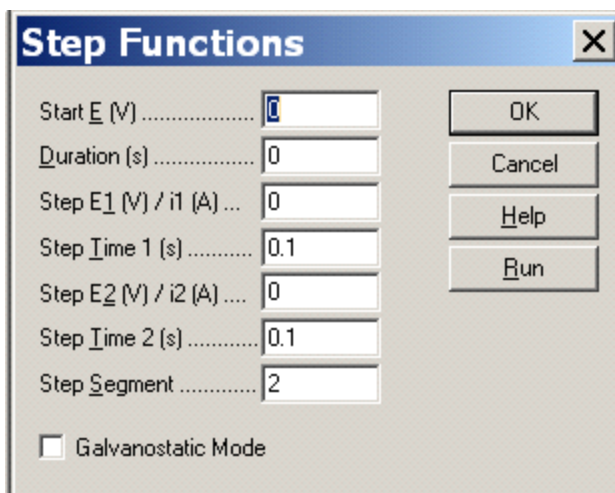

Parameter	Range	Description
Start E (V)	-10 - +10	Starting potential
Duration (s)	0 - 100000	Duration at Start E
Step E1 (V) / i1 (A)	-10 - +10	First step potential
Step Time 1 (s)	.0001 - 100000	Duration of each step
Step E2 (V) / i2 (A)	-10 - +10	Second step potential
Step Time 2 (s)	.0001 - 100000	Duration of each step
Step Segments	1 - 2000000000	Step segments; each segment is a half cycle
Galvanostatic Mode	Check or Uncheck	Galvanostatic or potentiostatic (unchecked) mode

Notes

1. The potential range between Start E, Step E1, and Step E2 should be less than 13.1 V.
2. If Duration is less than 0.001 sec, the Start E potential will be ignored.
3. The steps are applied in the sequence of Step E1, Step E2, Step E1, Step E2, ... Thus, the final potential will be Step E1 for an odd number of segments and Step E2 for an even number.

Run

Click the Run button to activate the step function generator. No data will be collected and displayed.

A status box will be displayed showing the number of steps completed, the remaining steps and the remaining time. Cancel this function by pressing the Stop pushbutton.

5.16 Preconditioning command

This dialog box opens the Preconditioning before Run dialog box. Use this command to condition the working electrode before running an experiment. This can be useful for cleaning the electrode among other purposes. Preconditioning occurs before the deposition or quiet time.

The Precondition command presents this dialog box.

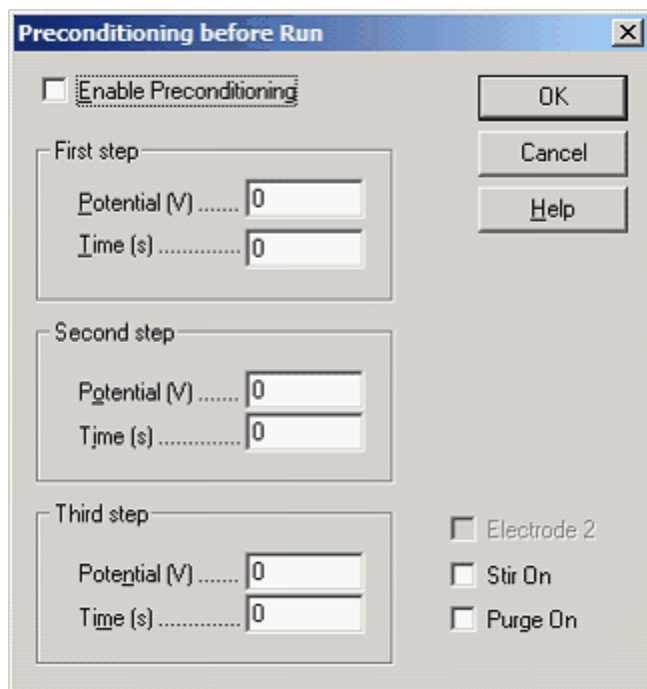

The working electrode will be conditioned with up to three potential steps.

Enable Preconditioning

Uncheck this box to disable preconditioning, which occurs before the deposition or quiet time.

Potential

The parameter range is from -10 to 10.

Time

The parameter range is from 0 to 6400. Set to 0 to skip a given step. If a nonzero value less than 1 msec is specified, the time control may not be accurate.

Stir On

Check this box to enable stirring during preconditioning.

Purge On

Check this box to enable purge during preconditioning.

5.17 Rotating Disk Electrode command

This command, available only in select models, opens the Rotating Disk Electrode Control dialog box.

Use this command to specify the rotation rate of the rotating disk electrode. You can also turn the rotator on and off in certain cases.

The Rotating Disk Electrode command presents this dialog box.

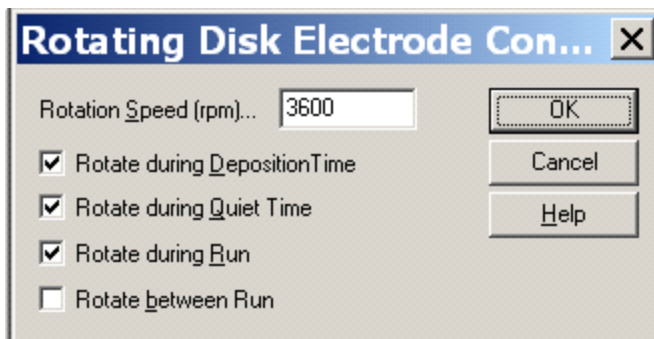

Rotation Speed (rpm)

Specify the speed of the rotating disk electrode from 0 to 10000 rpm. There are banana jacks on the rear panel of the instrument that will output 0 to 10 V corresponding to these speeds.

Rotate during Deposition Time

Check this box to turn the rotator on during deposition time in stripping analysis. This option can also be found in the Run Status command under the Control menu.

Rotate during Quiet Time

Check this box to turn the rotator on during quiet time. This option can also be found in the Run Status command under the Control menu.

Rotate during Run

Check this box to turn the rotator on during the experiment. This option can also be found in the Run Status command under the Control menu.

Rotate between Runs

Check this item to turn the rotator on between experiments. This option can also be found in the Run Status command under the Control menu.

5.18 Other command

This command opens the Other Controls dialog box. Use this command to control the cooling fan and working electrode static discharge protection.

The Other command presents this dialog box.

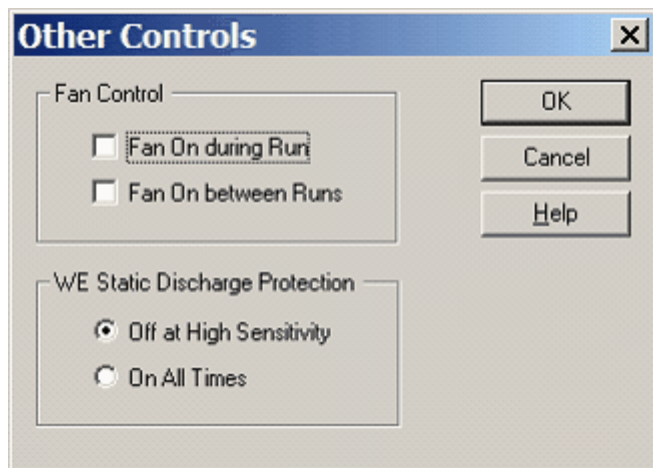

Fan Control

The instrument as all electronics will generate heat. Most components consume minimal power, but the voltage regulators, buffer amplifiers, and some other amplifiers may grow warm, particularly when higher currents are passing through the cell. Turning the fan on will help help to dissipate this heat and cool the instrument. However, the fan will also generate mechanical noise and electrical interference.

When current sensitivity is set to 0.01 A/V or lower or if automatic sensitivity is employed, the fan will be turned on automatically.

Check the appropriate box to turn the fan on during or between experiments.

WE Static Discharge Protection

The working electrode input amplifier is automatically protected from static discharge protection. However, the protection circuit generates extra leakage current at the input stage. This leakage current is normally less than 50 pA and is therefore not noticeable if the current is at nanoamperes or higher. For low current measurements, you may want to turn off discharge protection when the sensitivity is high. However, if you are doing electrochemical detection for electrophoresis, it is advisable for the protection circuit to be connected at all times to prevent possible high voltage feedthrough.

5.19 Stripping Mode command

This command opens the Stripping Control dialog box.

Use this command to enable/disable the stripping mode and specify deposition conditions. This command is only available for the following techniques: LSV, SCV, DPV, NPV, SWV, ACV, SHACV. It is not available in polarographic mode.

The Stripping Control command presents this dialog box.

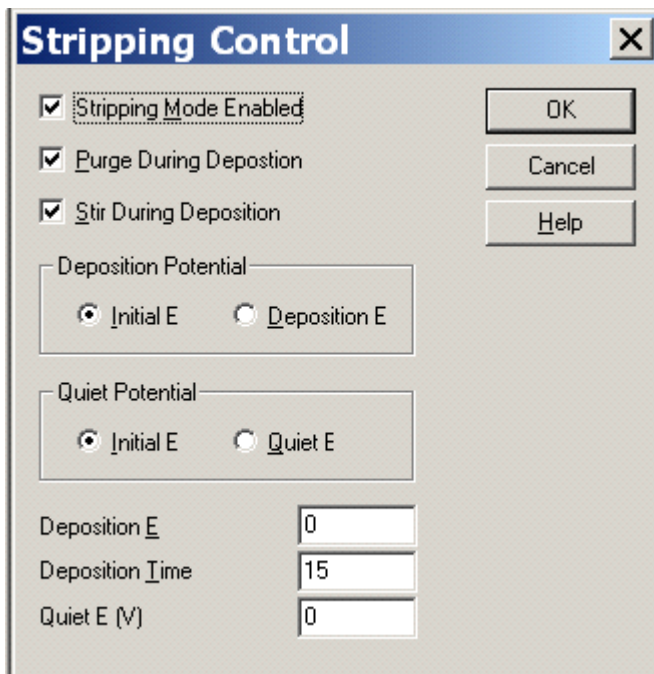

Stripping Mode Enabled

Check this box to enable stripping mode, inserting a deposition step before the quiet time step preceding the experiment. The deposition potential and time can be specified in this dialog box.

After the deposition period and before quiet time, the potential will be set back to its initial value. The potential scan during the stripping step will start from this value.

Purge During Deposition

When this box is checked, the system will purge the solution during the deposition period.

Stir During Deposition

When this box is checked, the system will stir the solution during the deposition period.

Deposition Potential

Specify whether the initial potential or the value specified in the Deposition E field is applied during the deposition period.

Quiet Potential

Specify whether the initial potential or the value specified in the Quiet E field is applied during the quiescent period.

Deposition E

Specify the value of the potential to be applied during the deposition period if the Deposition E option is selected under Deposition Potential; this value is ignored if Initial E is selected instead.

Deposition Time

Specify the deposition time from 0 to 100000.

Quiet E

Specify the value of the potential to be applied during the quiescent period if the Quiet E option is selected under Quiet Potential; this value is ignored if Initial E is selected instead.

Chapter 6 Graphics Menu

The **Graphics** menu offers the following commands:

Present Data Plot	Plot current data graphically.
Overlay Plots	Plot multiple data sets in a single graph.
Add Data to Overlay	Add data sets to existing overlay plot.
Parallel Plots	Plot multiple data sets in side by side graphs.
Add Data to Parallel	Add data sets to existing parallel plots.
Zoom In	Magnify graph region.
Manual Results	Report results manually.
Peak Definition	Define peak or wave parameters.
X-Y Plot	Input custom data for plotting
Peak Parameter Plot	Plot peak current or potential versus scan rate.
Semilog Plot	Generate current-potential semilog plot.
Special Plots	Generate special plots.
Graph Options	Set graph options.
Color and Legend	Set color and legend options.
Font	Set graph font options.
Copy to Clipboard	Copy graph to clipboard.

6.1 Present Data Plot command

Use this command to plot the currently active data.

You can rescale the X or Y axis by hovering over it, changing the mouse cursor to a double-headed arrow. Left-click and drag to rescale the axis. This provides a convenient way to zoom out further than the default scale and can be particularly useful for overlay plots when some data files go off the charts.

Double-clicking on an axis opens the Axis Options dialog box.

Double-clicking elsewhere in the plot area opens the Insert Text dialog box.

Other settings are available under the Graph Option, Color and Legend, and Font commands.

When data is saved to file, the display format is also saved, and is recovered when the file is loaded. This is also true for Overlay Plots, Parallel Plots, and Print Multiple Files.

This command is disabled if there is no currently active data.

Its toolbar button is:



Double-clicking on a graph axis will open this dialog box.

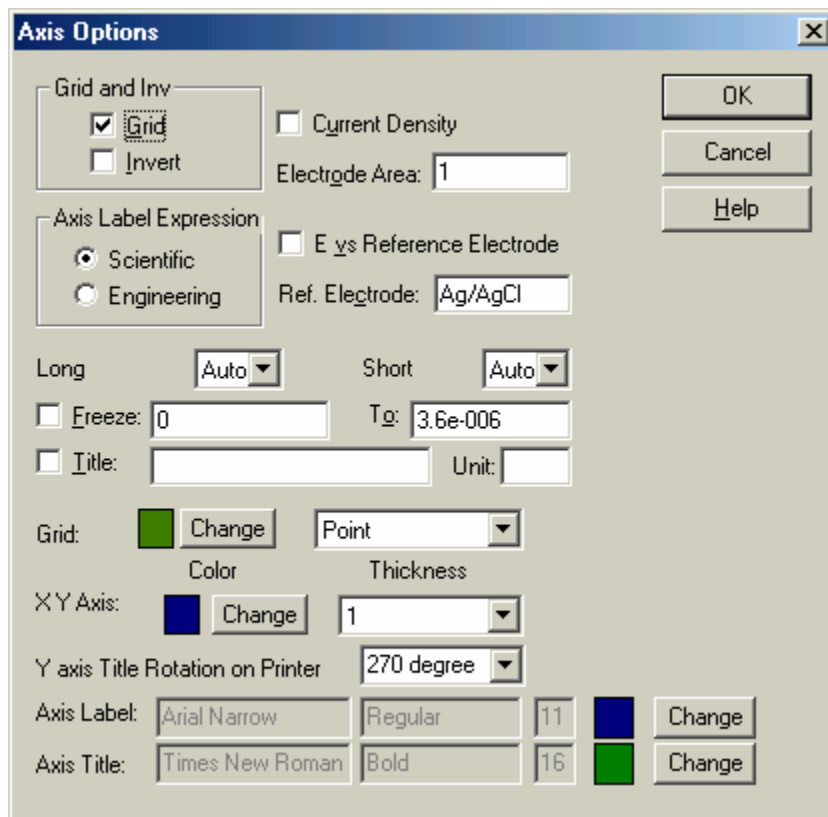

Many settings listed here can also be set using the Graph Options, Color and Legend, and Font commands. The options unique to this dialog box are:

Axis Label Expression

The format of axis values can be selected as Scientific (e.g., 1e-6A) or Engineering (e.g., 1 μ A). Warning: if you are using Oriental Windows (such as Chinese, Japanese, Korean), the "micro" symbol will not appear properly, you need to adjust the Windows setting using System command under the Setup menu. The "micro" symbol will then be expressed as "u".

Long/Short

These options allow you to customize long (major) and short (minor) ticks. You should freeze the axis scale when adjusting these settings manually.

Double-clicking on a graph opens this dialog box.

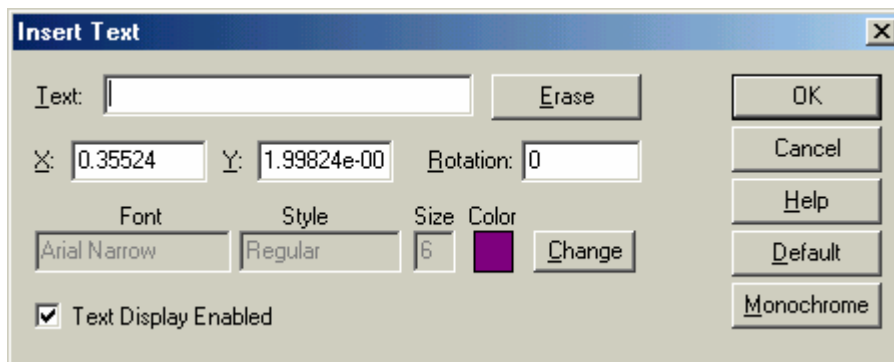

The entered text will be saved with the data when you save the data file. The following options allow you to type and format text in the data graphics field:

Text

Enter the text to be displayed. If you clear an existing Text field, text will be removed from the plot upon exiting the dialog box.

Erase

Clear the text field.

X and Y

Change the position of the text: X and Y give the precise coordinates of the upper-left corner of the first letter. The initial values indicate where you double-clicked.

Rotation

Rotate the text clockwise by an angle between 0 and 360 degrees.

Font

Click the Change button to specify the style, size, color, and font of the inserted text. This setting will be applied to all text inserted in the current plot.

Text Display Enabled

Uncheck this option to hide all text messages (the messages will not be deleted).

Default

Set the current font as the default for all data files.

Monochrome

Set the text color to black.

Depending on the active technique, data can be displayed in various formats:

Tech.	Data Display Formats
CV	sweep segment
TAFEL	log current ~ potential current ~ potential current density ~ potential
CA	$i \sim t$ $i \sim t^{1/2}$
CC	$Q \sim t$ $Q \sim t^{1/2}$
SWV	forward current reverse current forward and reverse current difference of forward and reverse current sum of forward and reverse current forward, reverse, and summation current forward, reverse, and difference current
ACV	absolute current phase selective current resistance capacitance
PSACV	absolute current phase selective current resistance capacitance
BE	charge ~ time current ~ time current ~ log(time)
IMP	Bode: $\log Z \sim \log(\text{freq})$ Bode: phase ~ log(freq) Bode: $\log Z'' \& Z' \sim \log(\text{freq})$ Bode: $\log Y \sim \log(\text{freq})$ Nyquist: $Z'' \sim Z'$ Admittance: $Y'' \sim Y'$ Warburg: $Z'' \& Z' \sim \omega^{-1/2}$ $Z' \sim \omega Z''$ $Z' \sim Z''/\omega$ $\cot(\text{phase}) \sim \omega^{1/2}$
IMP-t/IMP-E	$\log Z \sim t \text{ or } E$ phase ~ t or E $Z \sim t \text{ or } E$ $Z' \sim t \text{ or } E$ $Z'' \sim t \text{ or } E$ $Z' \& Z'' \sim t \text{ or } E$ $\log(Z' \& Z'') \sim t \text{ or } E$ $\log Y \sim t \text{ or } E$ $Y \sim t \text{ or } E$

IMP-E $Y' \sim t \text{ or } E$
 $Y'' \sim t \text{ or } E$
 $Y' \ \& \ Y'' \sim t \text{ or } E$
 $\log(Y' \ \& \ Y'') \sim t \text{ or } E$
 $R_s \sim E$
 $C_s \sim E$
 $R_p \sim E$
 $C_p \sim E$
 Mott-Schottky: $1 / (C_s \times C_s) \sim E$
 Mott-Schottky: $1 / (C_p \times C_p) \sim E$
CP, PSA potential \sim time
 $dE/dt \sim$ time
 $dt/dE \sim$ potential
 Potential \sim charge

6.2 Overlay Plots command

Use this command to plot multiple sets of data in a single graph. This is particularly useful for data comparison. A multi-colored legend will be automatically generated from the data filenames.

This command presents the following dialog box:

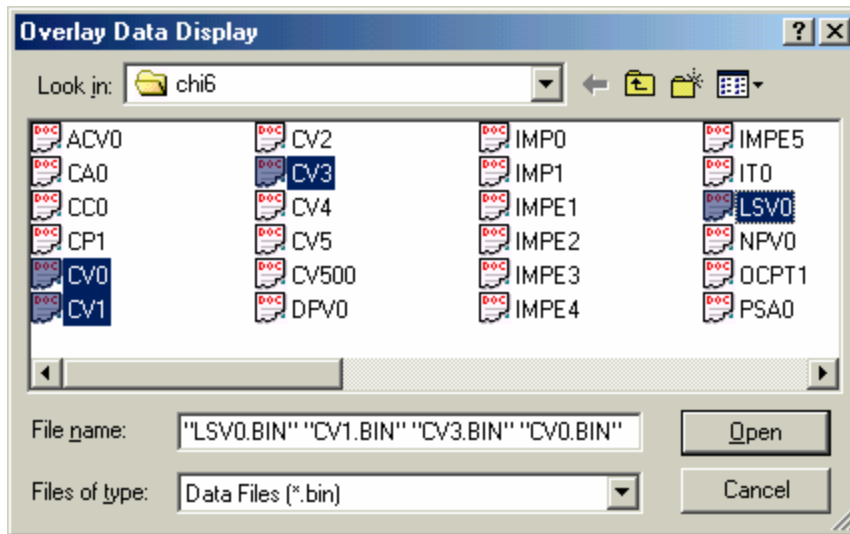

Select the data files you want to overlay with the currently active data. Multiple files can be selected. To select multiple files, point the mouse cursor to the filename you want to select and click the left mouse button while holding the Ctrl key down to select files one at a time.

This command allows you select multiple files in the same directory. In order to overlay data files located in a different directory or drive, use the Add Data to Overlay command.

The plot will be automatically scaled to fit the currently active data. If both X and Y values fall into the plot scale, the data point will be plotted.

The Graph Option, Color and Legend, and Font commands allow you customize your overlay plot.

This command does not check the type of data, and it is up to the user to ensure the meaningfulness of the overlay plot. It is disabled if there is no currently active data.

6.3 Add Data to Overlay command

This command complements the Overlay Plots command, allowing you to add more data to an existing overlay plot. This allows you to overlay data files from multiple directories or drives.

This command presents the following dialog box:

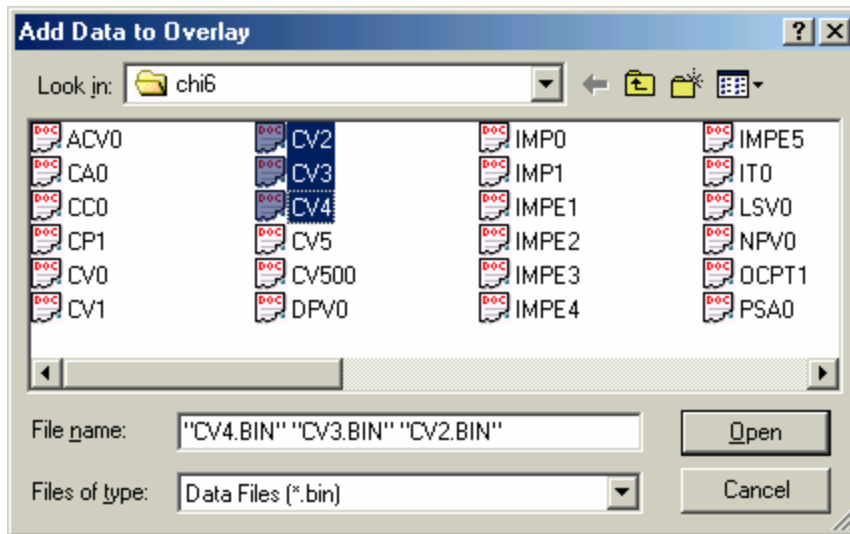

Multiple files can be selected. To select multiple files, point the mouse cursor to the filename you want to select and click the left mouse button while holding the Ctrl key down to select files one at a time.

The plot will be automatically scaled to fit the currently active data. If both X and Y values fall into the plot scale, the data point will be plotted.

The Graph Option, Color and Legend, and Font commands allow you customize your overlay plot.

This command does not check the type of data, and it is up to the user to ensure the meaningfulness of the overlay plot. It is disabled if there is no currently active data, or if the current plot is not an overlay plot.

6.4 Parallel Plots command

Use this command to plot multiple sets of data side by side. This is particularly useful to view data obtained with different techniques and for data comparison.

This command presents the following dialog box:

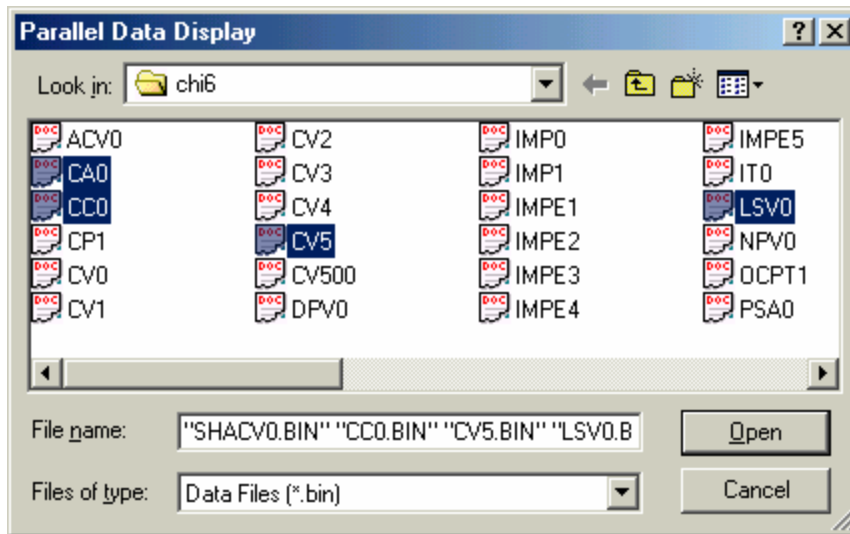

Select the data files you want to plot alongside the currently active data. Multiple files can be selected. To select multiple files, point the mouse cursor to the filename you want to select and click the left mouse button while holding the Ctrl key down to select files one at a time.

This command allows you select multiple files in the same directory. In order to plot data files located in a different directory or drive, use the Add Data to Parallel command.

Each plot will be automatically scaled to fit its individual data, unless the scale is frozen using the Graph Option command. In this case, all plots will have the same frozen scale.

The Graph Option, Color and Legend, and Font commands allow you customize your overlay plot.

This command is disabled if there is no currently active data.

6.5 Add Data to Parallel command

This command complements the Parallel Plots command, allowing you to add more data to an existing parallel plot. This allows you to plot data files from multiple directories or drives, as well as control the sequence of the data in the plots.

This command presents the following dialog box:

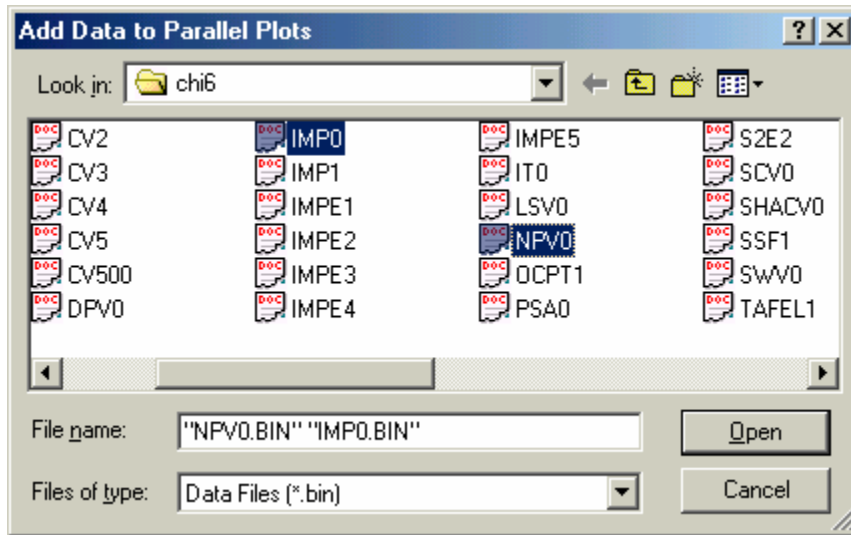

Multiple files can be selected. To select multiple files, point the mouse cursor to the filename you want to select and click the left mouse button while holding the Ctrl key down to select files one at a time.

Each plot will be automatically scaled to fit its individual data, unless the scale is frozen using the Graph Option command. In this case, all plots will have the same frozen scale.

The Graph Option, Color and Legend, and Font commands allow you customize your overlay plot.

This command is disabled if there is no currently active data or if the current plot is not a parallel plot.

6.6 Zoom In command

Use this command to magnify the data plot.

This command has a toolbar button:



To enter zoom mode, either click on the toolbar button or on its entry in the Graphics menu. A check mark appears next to the menu item when zoom mode is enabled, and its toolbar button will be depressed.

Once in zoom mode, the mouse cursor will appear as an up arrow in the data plot area. To zoom in, left-click and drag between diagonal corners of the box containing the area you want to view more closely. Release the mouse button to zoom in.

To zoom back out and exit zoom mode, click the Zoom In command or toolbar button again.

6.7 Manual Results command

Use this command to report peaks, wave potentials, currents, and area manually. You can determine the linear baseline(s) for a peak or wave graphically.

This command has a toolbar button:



To enter manual mode, either click on the toolbar button or on its entry in the Graphics menu. A check mark appears next to the menu item when manual mode is enabled, and its toolbar button will be depressed.

Once in manual mode, the mouse cursor will appear as an up arrow in the data plot area.

In order to report a peak or wave correctly, you must use the Peak Definition command to define the peak shape as Gaussian, diffusive, or sigmoidal. You can also choose between reporting peak (or wave) potential, half peak (or wave) potential, peak (or wave) currents, and/or peak area.

For a Gaussian peak, the baseline is determined by two points straddling the peak. Left-click at one point, drag to the other point, and release the left mouse button. A vertical line from peak to baseline will appear, with corresponding numerical values reported at the right side of the plot.

For a diffusive peak, the baseline is determined by extending the foot before the peak. Left-click at the foot, drag past the peak potential, and release the left mouse button. A vertical line from peak to baseline will appear, with corresponding numerical values reported at the right side of the plot. Notice that half peak area is reported in this case.

For a sigmoidal wave, two baselines are needed: one at the foot and one at the plateau of the wave. Left-click and drag to draw each baseline. A vertical line connecting the two baselines and crossing the middle of the wave will appear, with corresponding numerical values reported at the right side of the plot.

6.8 Peak Definition command

Use this command to define the peak shape as Gaussian, diffusive, or sigmoidal. You can also choose to report peak (or wave) potential, half peak (or wave) potential, peak (or wave) currents, and/or peak area.

The selected peak definition is used by both automatic and manual result reporting.

This command opens a technique-dependent dialog box: ACV, CV, IT, SWV, other.

This command has a toolbar button:



The general Peak Definition dialog box is:

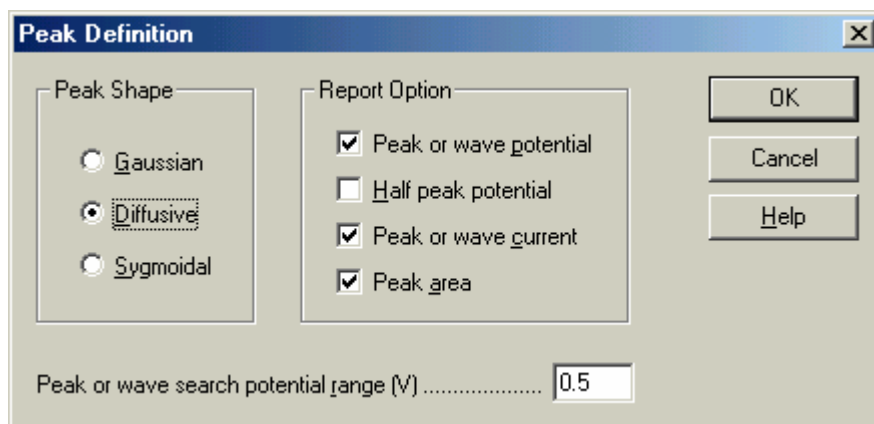

General Peak Definition options are:

Peak Shape

Define the peak shape as Gaussian, diffusive, or sigmoidal as appropriate to your data. A default peak shape is assigned based on the selected experimental technique. However, you can change this setting.

Report Option

You can also choose to report peak (or wave) potential, half peak (or wave) potential, peak (or wave) currents, and/or peak area.

Peak or wave search potential range

Depending on peak shape, the peak search potential range can be adjusted. For a broader peak or wave, the search potential range should be larger. The search potential range should include both sides of the peak or wave.

This parameter is only meaningful for automatic result reporting.

6.9 X-Y Plot command

This command opens the X-Y Plot dialog box.

Use this command to input data manually for plotting. Linear curve fitting can also be performed.

After the data have been input, click the OK button to generate the plot. The resulting X-Y plot is temporary and will disappear if other data display commands are invoked. You can use the Graph Option, Color and Legend, and Font commands to customize your plot. You can also save your data, overlay your data plots, or make parallel plots.

The X-Y Plot command presents this dialog box.

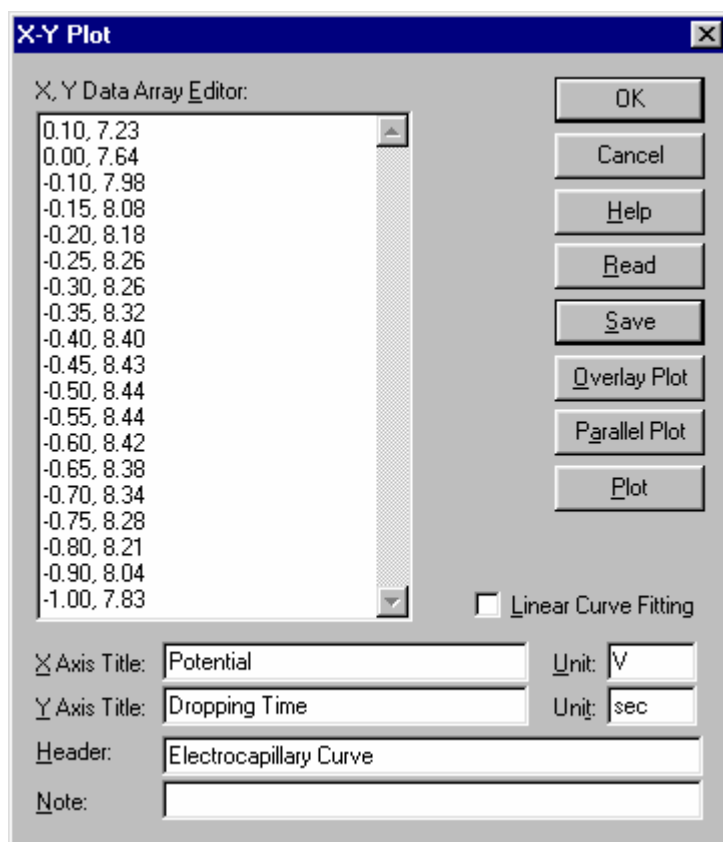

The following options allow you to edit your data and enter plot options:

X, Y Data Array Editor

Enter your own X Y data points. Use comma or space to separate X and Y values, one pair per line:

```
x1, y1
x2, y2
x3, y3
.....
```

Overlay Plot

Click this button to plot multiple sets of data in a single graph. To display both data markers and lines, save your data with two different names and select proper legends with the Color and Legend command. To freeze the axes, use the Graph Option command.

The program will display the Overlay Data Display dialog box so you can select the data files you want to plot along with the data in the X, Y Data Array Editor. Multiple files can be selected.

The plot will be automatically scaled to fit the data in the X, Y Data Array Editor. If both X and Y values fall into the plot scale, the data point will be plotted.

Parallel Plot

Click this button to plot multiple sets of data side by side.

The program will display the Parallel Data Display dialog box so you can select the data files you want to plot along with the data in the X, Y Data Array Editor. Multiple files can be selected.

Each plot will be automatically scaled to fit its individual data unless the scale is frozen using the Graph Option command. In this case, all plots will have the same frozen scale.

Plot

Use this command to plot the data entered in the X, Y Data Array Editor. The plot will be automatically scaled to fit the data range unless the scale is frozen using the Graph Option command.

X, Y Axis Title, Unit

Specify titles and units/dimensions for the X and Y axes.

Header

Enter the desired title (header) for the data. To display the header on the top of the plot, check the Header box using the Graph Option command.

Note

Enter any comments about the plot. The note will not be displayed on the plot, but will be saved in the data file. It allows you to put additional comments about the data and is well-suited for a brief description of the purpose and conditions of the experiment.

Read

Use this command to read data from file.

Save

Use this command to save data to file. XY titles, units, header, and note will be saved along with the data.

Linear Curve Fitting

Toggle least squares fit; if this box is checked, a best fit straight line will also appear on the plot.

6.10 Peak Parameter Plot command

This command opens the Peak Parameter vs Scan Rate Plot dialog box. Use this command to plot peak current or potential against the scan rate. This command can also perform a linear fit to the data.

This command works only for cyclic voltammetric (CV) or linear sweep voltammetric (LSV) data. For CV data, the system only searches for the currently active data segment.

After specifying the peak potential window and selecting the proper files, click OK to render the plot. The resulting plot is temporary and will disappear if other data display commands are invoked. You can use the Graph Option, Color and Legend, and Font commands to customize your plot.

The Peak Parameter Plot command opens this dialog box.

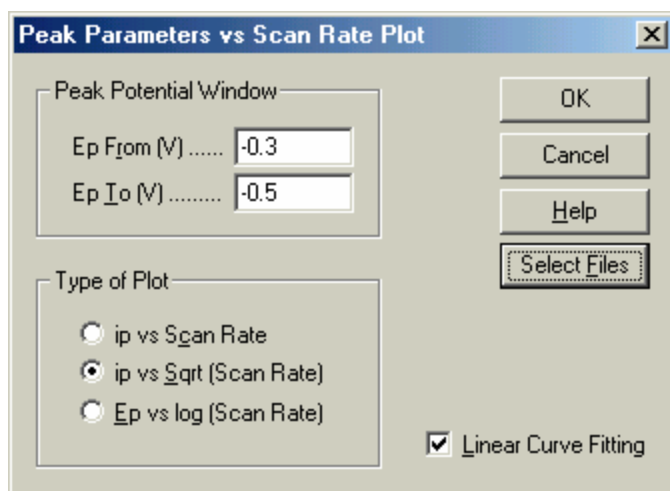

Peak Potential Window

Specify the potential range in which the program will search for peaks. The first peak in this potential range will be used for plotting.

Type of Plot

Plot peak current versus the scan rate, peak current versus the square root of the scan rate, or peak potential versus the logarithm of the scan rate.

For a reversible surface reaction, the peak current is proportional to the scan rate. For a reversible diffusive system, the peak current is proportional to the square root of the scan rate.

The peak potential should be independent of the scan rate for a reversible reaction. A change in peak potential with scan rate indicates either slow kinetics or chemical complexity.

Linear Curve Fitting

Checking this box will generate a linear least squares best fit line on the plot.

Select Files

Select data files to be plotted (CV or LSV only). Select at least three data files obtained at different scan rates.

6.11 Semilog Plot command

This command opens the Current-Potential Semilog Plot dialog box.

Use this command to display a current-potential semilog plot. This is useful in data analysis for steady-state responses. One can also convert a diffusive or peak-shaped response by semi-integral or full integral to a sigmoidal curve and display a semilog plot.

For a reversible reaction, the intercept on the potential axis is the half wave potential and the slope should be $0.059/n$ V. Any deviation from this expected slope indicates slow kinetics or complexity of the electrode reaction.

This command can also perform a linear fit to the data.

After specifying the peak potential window and selecting the proper files, click OK to render the plot. The resulting plot is temporary and will disappear if other data display commands are invoked. You can use the Graph Option, Color and Legend, and Font commands to customize your plot.

The Semilog Plot command presents this dialog box.

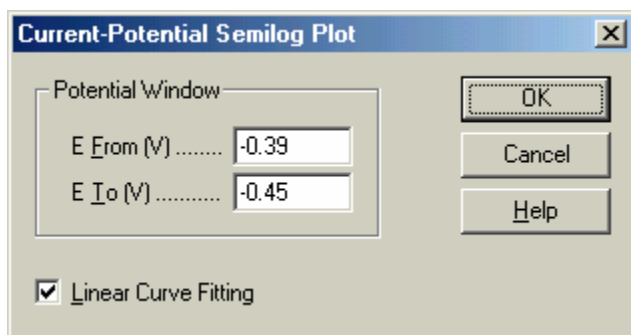

Potential Window

Enter the range of potential values to be plotted. The potential window should be near the half wave potential and within $\pm 0.059/n$ V. Data points outside the specified potential window will be ignored.

Linear Curve Fitting

Checking this box will generate a linear least squares best fit line on the plot.

6.12 Special Plot command

Use this command to display special plots if available.

For linear sweep voltammetry (LSV), this command opens the Polarization Resistance Plot dialog box. The resulting plot is temporary and will disappear if other data display commands are invoked. You can use the Graph Option, Color and Legend, and Font commands to customize your plot.

The Special Plot command presents this dialog box for the LSV technique.

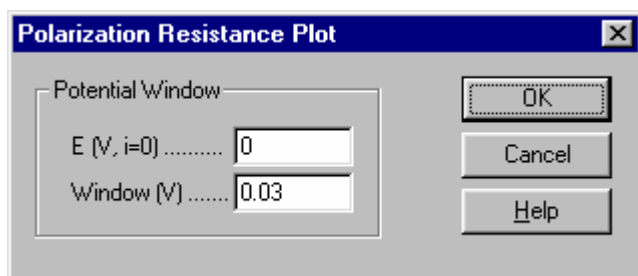

After this command is invoked, the program will check for a potential with zero current. If found, this potential is set as E (V, I=0). Otherwise, a warning "Potential at zero current not found" will be issued.

After specifying the center potential and potential range, click OK to construct the polarization resistance plot.

6.13 Graph Options command

This command opens the Graph Options dialog box.

Use this command to selectively turn on or off plot captions, grids, axis inversion. You can also freeze axes, customize axis titles, and write notes that can be saved together with the data. Most other parameters will be saved when you exit the program and reloaded when you restart the program.

This command has a toolbar button:



The Graph Options command presents this dialog box.

Depending on the currently selected experimental technique, specialized options may also be available. For context-specific details, click the Help button in the currently open dialog box.

The following options are available for all techniques:

Screen

Uncheck the corresponding box to hide the header, axis, baseline, parameters, or results on screen.

The header is the title shown at the top of the plot, entered in the Header field in this dialog box.

The baseline is drawn to visually define a peak or wave.

Screen options are independent of the printer options described below.

Printer

Uncheck the corresponding box to hide the header, axis, baseline, parameters, or results on printed output.

Printer options are independent of the screen options described above.

Grid and Inv

Uncheck the corresponding box to hide the X or Y grid or to disable axis inversion.

Check X or Y inversion to flip the X or Y axis temporarily. To invert axis polarity permanently, use the System command in the Setup menu.

X, Y Freeze

Freeze the X or Y axis range by checking the corresponding box and enter the desired min and max. The X and Y axis can be frozen independently.

When the corresponding box is unchecked, the X or Y scale will revert to the original scale of the present plot.

In SECM mode, the Z axis can also be frozen similarly.

Due to the program requirement for an integer number of ticks, an axis may be unable to be frozen at the scale you entered

X, Y Title

The program automatically provides default axis titles for each electrochemical technique. To override these defaults, check the corresponding box and enter the desired title.

Unit

Specify the units or dimensions of customized axis titles.

X, Y Scale

These values change the size of the plot (the default full-size value is 1). This is particularly useful when you want to print the plot for publication or paste the plot into a word processor.

Cursor Lock to Data Points

This option controls the behavior of the mouse cursor in the plot area. The X and Y coordinates of the cursor will be displayed in both modes.

When Lock is selected, the cursor will be locked to data points; when you move the mouse in the X direction, the cursor will move along the data curve. This is particularly useful for identifying data points.

When Free is selected, the cursor will move freely in the XY plane.

This option is not available for the SECM technique.

Current Density

Check this box to display current density.

Electrode Area

This value is used to calculate the current density.

E vs Reference Electrode

Specify the name of the reference electrode used in the experiment in the Ref. Electrode field, e.g., "Ag/AgCl".

The default potential axis title is "Potential / V". Check the "E vs Reference Electrode" to append the Ref. Electrode field to the potential axis title, e.g., "Potential / V vs Ag/AgCl".

Header

Enter your header in this field. To display this header at the top of your plot, check the Header box under Screen and/or Printer options in this dialog box.

Note

Enter your notes in this field. Notes will not be displayed on the screen or printed, but will be saved in the data file, allowing you to add comments about the experiment and remind yourself later about the purpose and the conditions of the experiment.

6.14 Color and Legend command

This command opens the Color Selection dialog box.

Use this command to specify color and legend options for your graphical plots. You can change the color of the background, axes, grid, and data curves. You can also change marker/line options ("Legend") for data curves and the grid.

Color and legend options will be saved when you exit the program and will be reloaded when you restart the program.

To change text color, use the Font command instead.

This command has a toolbar button:



The Color and Legend command presents a dialog box.

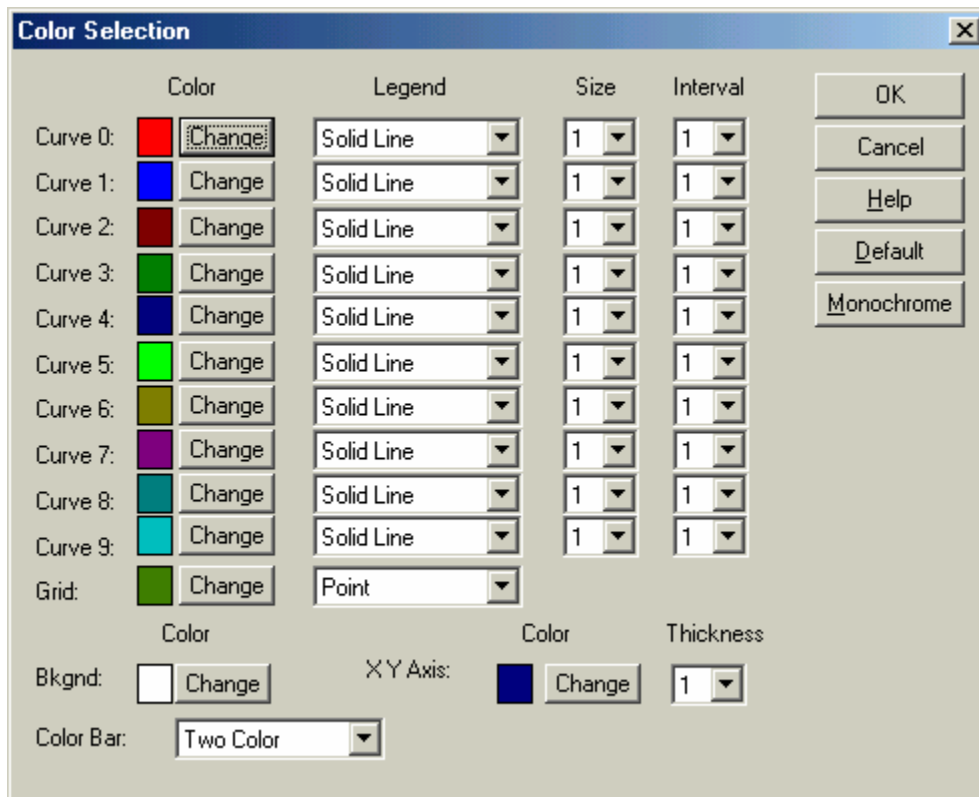

The following options allow you to specify the colors and the data marker/line options of the plot:

Curve

Curve 0 indicates the currently active data. Curves 1-9 indicate Overlay Plots.

Color

You can specify the color of data curves, the grid, the background, and the axes by clicking the corresponding Change button to open a system Color dialog box.

To adjust text color, use the Font command instead.

Legend

Specify the style ("legend") of the marker/line style for the data curves and grid, e.g., line, point, circle.

When the legend is chosen to be "point", data curves curve or the grid may not print correctly. This has been found to be a printer-specific problem. Please consult your printer documentation or choose a different legend if this occurs.

Size

Specify the marker size/line thickness.

Interval

Setting this value to N plots every Nth data point (default 1). A larger value of Interval lowers your data point, which is useful for Overlay Plots or different legends.

Default

Clicking this button will reset all colors and legends to the program's default values.

6.15 Font command

This command opens the Font Selection dialog box.

Use this command to adjust the appearance of the text used in the plot. The font, style, size, and color can be adjusted separately for all text elements. You can also rotate the Y axis title for printing.

Font options will be saved when you exit the program and will be reloaded when you restart the program.

This command has a toolbar button:



The Font command presents a dialog box.

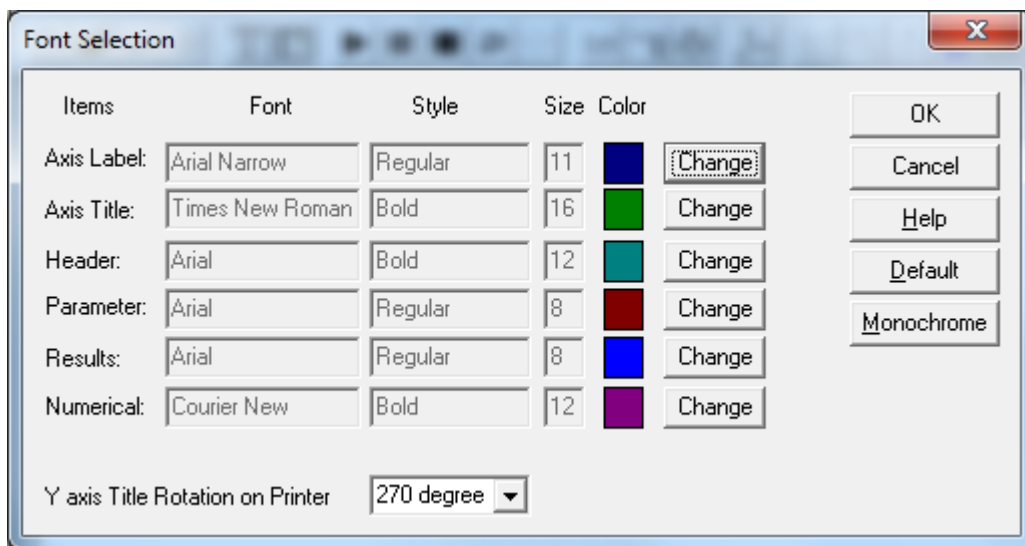

To change the font, style, size or color of the text, click the Change button to the right of the corresponding item.

The Y axis title should read from bottom to top. However, different printers have been found to follow different character rotation conventions, so you may have to adjust the rotation angle to obtain the correct orientation for your printer.

Pressing the Default button will reset all font settings to the program defaults.

6.16 Copy to clipboard command

Use this command to copy the currently displayed plot to the clipboard. You can then paste it into a word processor or any other Windows based program. This command will work during a run or a digital simulation. Alternatively, use the Alt+PrtScn system keyboard shortcut.

This command has a toolbar button:



Chapter 7 DataProc Menu

The **DataProc** menu offers the following commands:

Smoothing	Smooth data by least squares or bandwidth filtering.
Derivatives	Compute numerical derivatives of data up to 5th order.
Integration	Integrate data numerically.
Semiinteg and Semideriv	Take semi-integral or semi-derivative.
Interpolation	Insert interpolated data points.
Baseline Fitting & Subtract	Fit and subtract a polynomial baseline from data.
Linear Baseline Correction	Correct baseline visually.
Data Point Removing	Remove data points visually.
Data Point Modifying	Modify data points visually.
Background Subtraction	Subtract background data from present data.
Signal Averaging	Average multiple data sets.
Mathematical Operation	Perform mathematical operation on X or Y data.
Fourier Spectrum	Compute Fourier spectrum of data.

7.1 Smoothing command

This command opens the Smoothing dialog box. Use this command to smooth the currently active data.

This command has a toolbar button:



The Smoothing command presents this dialog box.

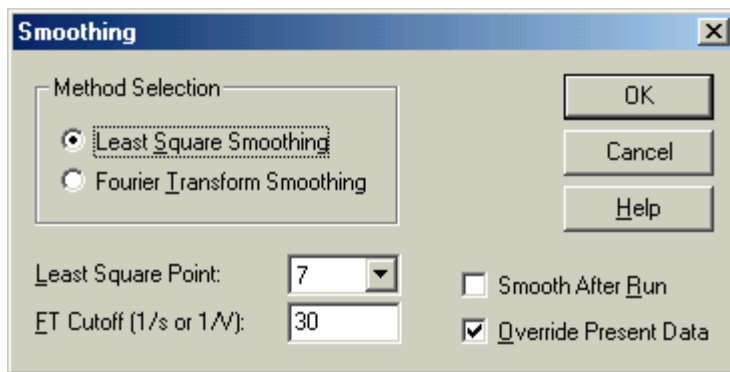

The following options allow you to specify the smoothing method and corresponding parameters:

Method Selection

Least square and Fourier transform (FT) smoothing options are available.

Least Square Point

Least square smoothing requires an odd number of points between 5 and 49. More points will result in better smoothing, but may also cause distortion.

The program performs least square smoothing using the algorithm of Savitzky and Golay. For more details about this algorithm, please refer to "Smoothing and Differentiation of Data by Simplified Least Squares Procedures", *Anal. Chem.*, 36, 1627-1639 (1964).

FT Cutoff (1/s or 1/V)

Specify the filter cutoff frequency. For a time-based experiment (e.g., CA, CC, TB), the Fourier-conjugate frequency has units of 1/s or Hz; voltammetry, it has units of 1/V. In the latter case, the physical meaning is how many signal cycles are allowed in one volt of potential range. A lower cutoff will result in better smoothing, but may also cause distortion.

The program performs Fourier transform smoothing using the algorithm of D.E. Smith et al. For more details about this algorithm, please refer to "Some Observations on Digital Smoothing of Electroanalytical Data Based on the Fourier Transformation", *Anal. Chem.*, 45, 277-284 (1973).

In general, Fourier transform smoothing is very effective. Distortion may be minimal, if the signal band is well separated from the noise band. However, this method is more time-consuming than least square smoothing.

Smooth After Run

Check this box to enable automatic smoothing after each experimental run. Certain techniques do not

allow smoothing (e.g., TAFEL, BE, IMP). This option can also be turned on or off from the Run Status command under the Control menu.

Override Present Data

Check this box to replace the currently active data with the resulting smoothed data. If this box is not checked, the smoothed data will only be displayed, without overriding the currently active data, and invoking the Present Data Plot command will display the original data.

7.2 Derivatives command

This command opens the Derivative dialog box. Use this command to compute the numerical derivative of the currently active data.

After performing a first order derivative, the Y axis has dimensions of Y unit / X unit (A/V for voltammetry, A/s for i-t curves, etc.). The new unit is not explicitly expressed, but you should be aware of it.

This command has a toolbar button:



The Derivatives command presents this dialog box.

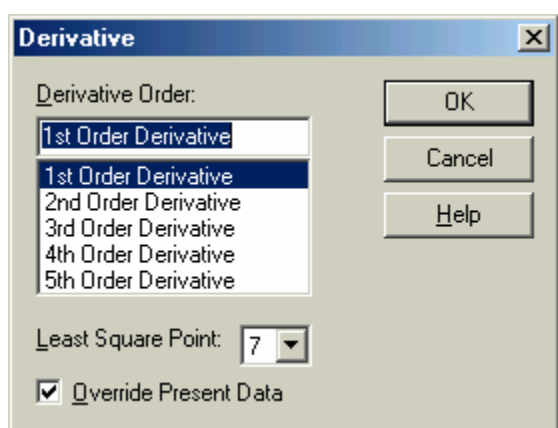

Derivative Order

Up to fifth order derivatives can be taken.

Least Square Point

Derivative computation requires an odd number of points between 5 and 49. More points will result in better smoothing, but may also cause distortion. Numerical differentiation will inherently amplify high frequency noise, so a relatively large number of points should be considered. More points will result in less noisy derivative data, but may also cause distortion.

The program performs numerical differentiation using the algorithm of Savitzky and Golay. For more details about the Savitzky and Golay algorithm, please refer to "Smoothing and Differentiation of Data by Simplified Least Squares Procedures", Anal. Chem., 36, 1627-1639 (1964).

Override Present Data

Check this box to replace the currently active data with the resulting derivative data. If this box is not checked, the derivative data will only be displayed, without overriding the currently active data, and invoking the Present Data Plot command will display the original data.

7.3 Integration command

This command opens the Integration dialog box. Use this command to integrate the currently active data.

After performing integration, the Y axis has dimensions of Y unit \times X unit (A/V for voltammetry, coulombs for i-t curves, etc.). The new unit is not explicitly expressed, but you should be aware of it.

The Integration command presents this dialog box.

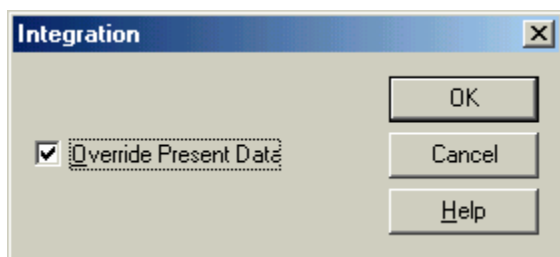

Override Present Data

Check this box to replace the currently active data with the resulting integrated data. If this box is not checked, the integrated data will only be displayed, without overriding the currently active data, and invoking the Present Data Plot command will display the original data.

7.4 Semiinteg and Semideriv command

This command opens the Semi-derivative and Semi-integral dialog box.

Semi-derivatives and semi-integrals can be used for a variety of purposes. For instance, the semi-derivative can be used to convert a diffusive peak to a Gaussian peak. This allows higher resolution and facilitates measurement. A diffusive peak can also be converted to a sigmoidal wave to yield a time-independent steady state current plateau. In polarographic theory, current-potential semilog analysis can be used to interpret the resulting data.

This command has a toolbar button:



The Semiinteg and Semideriv command presents this dialog box.

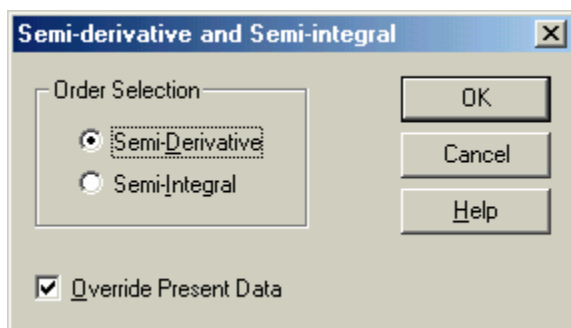

Order Selection

Both semi-derivative and semi-integral can be computed.

Override Present Data

Check this box to replace the currently active data with the resulting convoluted data. If this box is not checked, the convoluted data will only be displayed, without overriding the currently active data, and invoking the Present Data Plot command will display the original data.

7.5 Interpolation command

This command opens the Interpolation dialog box. Use this command to insert additional data points into the currently active data.

The Interpolation command presents this dialog box.

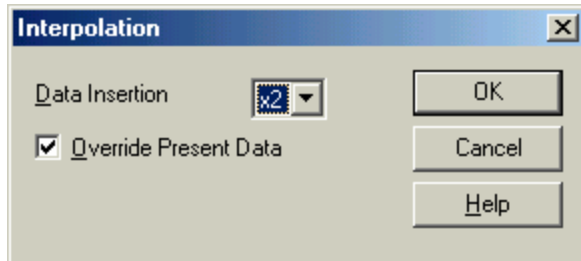

Data Insertion Density

The larger the multiplier, the more points will be inserted between the existing data points. When the number of data points exceeds the available memory size, a warning will be given and the command will terminate. The multiplier can only be a power of 2. Fourier transform is used in this case.

Override Present Data

Check this box to replace the currently active data with the resulting interpolated data. If this box is not checked, the interpolated data will only be displayed, without overriding the currently active data, and invoking the Present Data Plot command will display the original data.

7.6 Baseline Fitting & Subtraction command

This command opens the Baseline Fitting & Subtraction dialog box.

Use this command to fit the baseline and subtract the fitting curve from the currently active data. This is very useful for peak evaluation.

In order to perform Baseline Fitting and Subtraction, you need to specify the potential on both sides of the peak base, the algorithm, and the order of fit.

Baseline Fitting and Subtraction only works for certain peaks and experimental techniques.

If more than one segment of data is available, such as CV data, you can choose the segment to operate on with the Graph Option command under the Graphics menu.

This command has a toolbar button:



The Baseline Fitting & Subtraction command presents this dialog box.

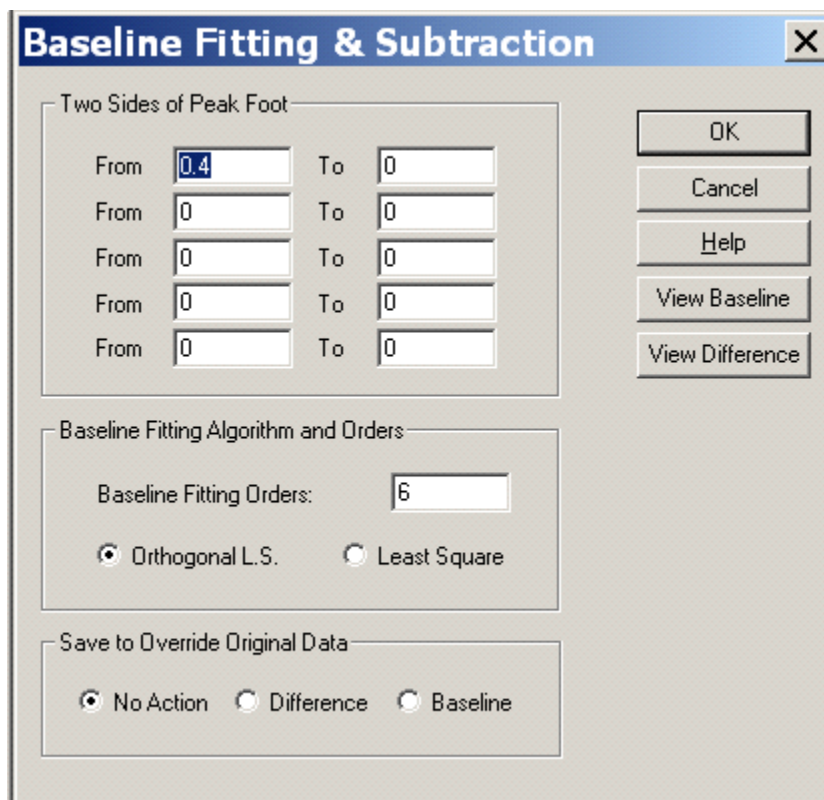

The following options allow you to select fitting parameters and data file options:

Two sides of Peak Foot

When fitting the baseline, data points corresponding to peaks must not be included. In a mountaineering analogy, the user must mark off the "feet" (data interval) of each peak. Adjusting peak foot values can improve your baseline fit.

If there are multiple peaks, feet need to be specified for each peak (up to 5), or alternatively, you can

also specify a large potential or time range covering several peaks.

Baseline Fitting Algorithm and Orders

Orthogonal Least Square and Least Square algorithms are available for fitting the baseline, both utilizing polynomial fits. The Baseline Fitting Orders field specifies the order of the polynomial fit: first order stands for linear fitting, $aX+b$; second order stands for aX^2+bX+c fitting; and so on.

Save to Override Original Data

This option determines what data are output upon clicking the "OK" button.

When "No Action" is selected, the original data will be plotted with the fitted baseline, and the original data remains unchanged.

When "Difference" is selected, the original data will be replaced by the difference between the original data and the fitted baseline.

When "Baseline" is selected, the fitted baseline data will be saved.

View Baseline

This button plots the original data and the fitted baseline together to evaluate the fitting results. Use this command to preview the quality of the baseline fit. The original data remains unchanged. Use the Present Data Plot command under the Graphics menu to display the original data.

If peak defining lines obstruct your view, you can turn off the "Screen Baseline" option by using the Graph Options command under the Graphics menu.

View Difference

This button plots the difference between the original data and the fitted baseline. This is helpful when evaluating the fitting results. Use this command to preview the quality of the baseline fit. The original data remains unchanged. Use the Present Data Plot command under the Graphics menu to display the original data.

7.7 Linear Baseline Correction command

This command opens the Baseline Correction dialog box.

Use this command to visually correct the baseline of the currently active data. You can compensate a sloped baseline and shift the DC level of the curve.

The Linear Baseline Correction command presents this dialog box.

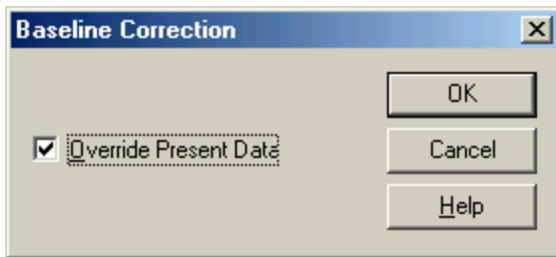

To perform baseline correction, click the OK button first. The mouse cursor will change to an up arrow.

Left-click at the starting point and drag to define a sloped baseline. When the mouse button is released, this line is subtracted from your data. X values not covered by the line will be unaffected.

To shift the DC level, left-click and drag to create a horizontal line, which defines the new zero of the entire curve. You don't have to draw a line to cover the entire X range.

If more than one segment of data is available, such as CV data, you can choose the segment to operate on with the Graph Option command under the Graphics menu.

This command is applied only once per invocation. To compensate or shift the baseline more than once, invoke this command repeatedly.

Override Present Data

Check this box to replace the currently active data with the resulting baseline corrected data. If this box is not checked, the baseline corrected data will only be displayed, without overriding the currently active data, and invoking the Present Data Plot command will display the original data.

7.8 Data Point Removing command

This command opens the Data Point Removing dialog box. Use this command to remove unwanted data points from the beginning or end of the currently active data.

The Data Point Removing command presents this dialog box.

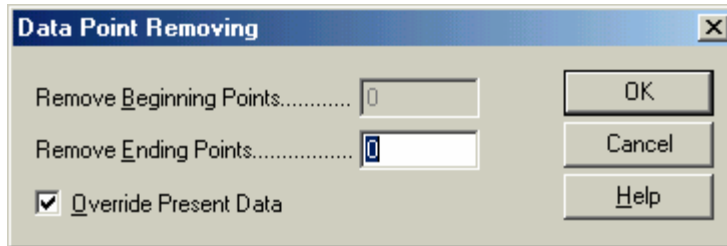

Remove Beginning Data Points

Specify the number of data points to be removed from the beginning of the data set. If this number is zero, no points will be removed from the beginning.

Remove Ending Data Points

Specify the number of data points to be removed from the end of the data set. If this number is zero, no points will be removed from the end.

Override Present Data

Check this box to replace the currently active data with the new data after data point removal. If this box is not checked, the new data will only be displayed, without overriding the currently active data, and invoking the Present Data Plot command will display the original data.

7.9 Data Point Modifying command

This command opens the Data Point Modifying dialog box. Use this command to visually modify the data points of the currently active data, e.g., to correct data points due to a bad mercury drop.

The Data Point Modifying command presents this dialog box.

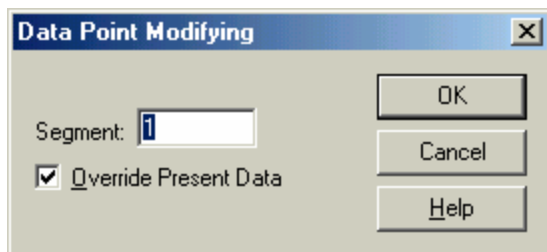

To modify data points, click the OK button first. The mouse cursor will change to an up arrow.

When you move the mouse cursor in the data display region, crosshairs will appear at the data point corresponding to the X axis position of the mouse cursor. Move the mouse horizontally to select the data point you want to modify. When the crosshairs appear at the selected point, left-click and drag vertically to move the data point, and release the mouse button to finish. The old data point will be erased and a new data point will appear at the new position.

Segment

Choose the data set (segment) you want to modify. The range of valid values will depend on the electrochemical technique used.

Override Present Data

Check this box to replace the currently active data with the modified data. If this box is not checked, the modified data will only be displayed, without overriding the currently active data, and invoking the Present Data Plot command will display the original data.

7.10 Background Subtraction command

This command allows you to calculate the difference between two data sets. First you have to measure the blank solution, save the data file. Then run the sample. You can now use this command to do a background subtraction.

In order to do a background subtraction, the background data should be the same type of experiment and the same X data array. Otherwise an error message will be issued, and the command will be terminated.

This command presents the following dialog box:

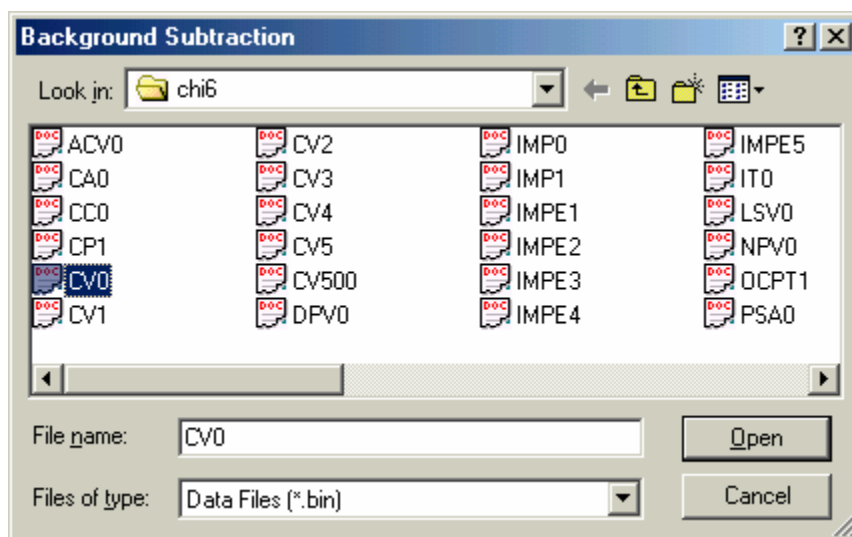

This allows you to select the background data file that will be subtracted from the currently active data.

File name

Type or select the filename you want to subtract. This box lists files with the extension you select in the "Files of type" box.

You don't have to type the extension. The program will automatically attach an extension of ".bin" to the filename. Other extensions are not allowed.

Files of type

Select the type of file you want to subtract. Only the ".bin" type (binary data file) will be available.

7.11 Signal Averaging command

This command allows you to perform signal averaging between the currently active data and files saved on disk. The currently active data is always included in the averaging, which is computed by simply adding together several sets of data and dividing the result by the number of data sets. Data sets whose X values differ from the currently active data will be ignored.

This command presents the following dialog box:

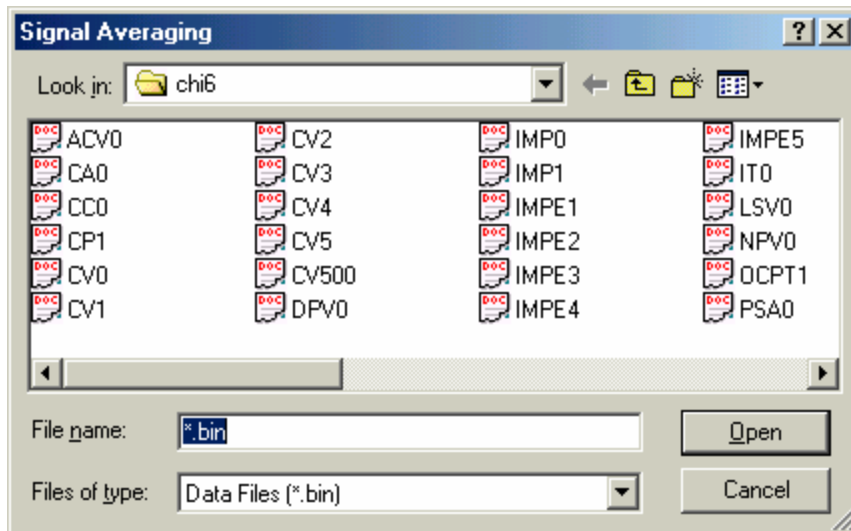

This allows you to select the files that will be averaged with the currently active data.

File name

Type or select the filename(s) you want to average. The box above lists files with the extension you select in the "Files of type" box.

Multiple files can be selected for averaging.

You don't have to type the extension. The program will automatically attach an extension of ".bin" to the filename. Other extensions are not allowed.

Files of type

Select the type of file you want to convert. Only the ".bin" type (binary data file) will be available.

7.12 Mathematical Operation command

This command opens the Math Operation dialog box.

Use this command to perform mathematical operations on the currently active data. The allowed operations are addition, subtraction, multiplication, division, exponential, logarithm, square, square root, and reciprocal, applicable to both X and Y data values.

The Mathematical Operation command presents this dialog box.

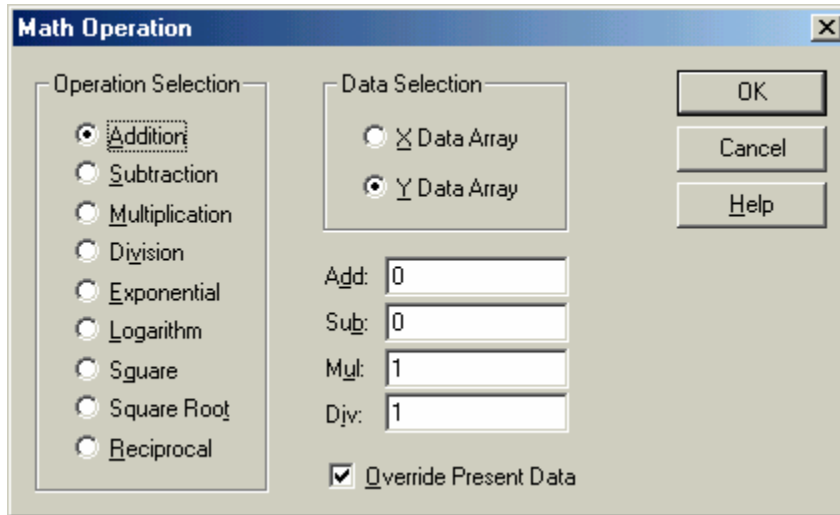

Operation Selection

Select the operation you want to apply to the data. If addition, subtraction, multiplication or division is chosen, you have to provide the second operand in the appropriate field.

Data Selection

Select either the X data array or the Y data array as the target of the mathematical operation.

Override Present Data

Check this box to replace the currently active data with the operated data. If this box is not checked, the operated data will only be displayed, without overriding the currently active data, and invoking the Present Data Plot command will display the original data.

7.13 Fourier Spectrum command

This command opens the Fourier Spectrum dialog box. Use this command to obtain the Fourier spectrum of the currently active data.

The Fourier Spectrum command presents this dialog box.

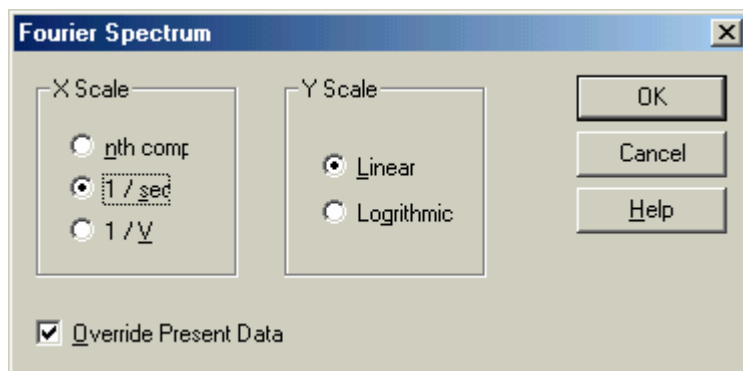

X Scale

The X data array of the Fourier spectrum can have an nth component, a 1/s scale, or a 1/V scale, depending on your choice.

An nth component scale is generally used. It is available for all techniques. Its physical meaning is derived from experimental parameters.

The 1/s and 1/V scales have a clear physical meaning. For time-based experiments, the 1/s scale should be used, and the 1/V is invalid; for voltammetric experiments, the 1/V should be used since the 1/s scale may not be valid. CV and LSV experiments are special cases; both 1/s and 1/V scales can be used here.

Y Scale

The Y data array contains the Fourier coefficients and can have either a linear or logarithmic scale.

Override Present Data

Check this box to replace the currently active data with the Fourier spectrum data. If this box is not checked, the Fourier spectrum data will only be displayed, without overriding the currently active data, and invoking the Present Data Plot command will display the original data.

Chapter 8 Analysis Menu

The **Analysis** menu offers the following commands:

Calibration Curve	Plot a calibration curve.
Standard Addition	Determine concentration by Standard Addition.
Data File Report	Generate report file.
Time Dependence	Plot time-dependence of concentration.
Special Analysis	Perform special analysis for select techniques.

8.1 Calibration Curve command

This command opens the Calibration Curve dialog box, which allows you to specify options for calibration curve calculation and/or plotting.

The Calibration Curve command presents this dialog box.

	Concentration	Peak Height		
Standard 1:	100	2.391e-007		
Standard 2:	200	4.782e-007		
Standard 3:	300	7.023e-007	Slope:	2.2788e-009
Standard 4:	400	9.272e-007	Intercept:	1.65199e-008
Standard 5:	500	1.154e-006	Correlation:	0.999931
Standard 6:	0	0		
Unknown:	228.62	5.375e-007		
X Axis Title:	Concentration		X Axis Unit:	ppb
Y Axis Title:	Peak Current		Y Axis Unit:	A
Header:	Cu in waste water			
Note:				

Standard

Enter the concentration and peak height/current obtained from standard solutions.

Unknown

Enter the peak height of the unknown species if available to allow calculation of its concentration.

X Axis Title

Enter the desired X-axis title (e.g., Concentration) to be plotted.

X Axis Unit

Enter the X Axis unit or dimension (e.g., ppm or M) to be plotted.

Y Axis Title

Enter the desired Y axis title (e.g., Peak Current) to be plotted.

Y Axis Unit

Enter the signal unit or dimension (such as A) to be plotted.

Header

Enter the desired title (header) for the data. To display the header on the top of the plot, check the

Header box using the Graph Option command.

Note

Enter any comments about the plot. The note will not be displayed on the plot, but will be saved in the data file. It allows you to put additional comments about the data and is well-suited for a brief description of the purpose and conditions of the experiment.

Read

Use this command to read data from file.

Save

Use this command to save data to file. XY titles, units, header, and note will be saved along with the data.

Calculate

Use this command to calculate the slope, intercept and correlation coefficient of the calibration curve. If the unknown peak height is given, the unknown concentration will also be calculated.

Plot

Use this command to plot the calibration curve. The plot will be automatically scaled according the data range. To freeze the scale, please use the Graph Option command.

8.2 Standard Addition command

This command opens the Standard Addition dialog box.

Use this command to calculate the concentration of the unknown by standard addition. Namely, the unknown is measured first and its peak height is recorded. Then the standard solutions are added repeatedly, measuring the peak height of the unknown after each standard addition. Usually, the added volume is much smaller than the total volume in order to maintain the sample compositions and have the same matrix effect. The increment concentration should be comparable to the unknown.

The Standard Addition command presents this dialog box.

	Concentration	Peak Height
Unknown:	149.884	3.425e-007
Addition 1:	100	5.629e-007
Addition 2:	200	7.961e-007
Addition 3:	300	1.033e-006
Addition 4:	0	0

Slope: 2.2851e-009
Correlation: 0.999933

X Axis Title: Concentration X Axis Unit: ppb
Y Axis Title: Peak Current Y Axis Unit: A

Header: Pb in water water
Note:

The following options allow you to specify data calculating the concentration of the unknown species or plotting:

Unknown

Enter the peak height of the unknown species to allow calculation of its concentration.

Addition

Enter the concentration and peak height/current after adding standard solutions.

X Axis Title

Enter the desired X-axis title (e.g., Concentration) to be plotted.

X Axis Unit

Enter the X Axis unit or dimension (e.g., ppm or M) to be plotted.

Y Axis Title

Enter the desired Y axis title (e.g., Peak Current) to be plotted.

Y Axis Unit

Enter the signal unit or dimension (such as A) to be plotted.

Header

Enter the desired title (header) for the data. To display the header on the top of the plot, check the Header box using the Graph Option command.

Note

Enter any comments about the plot. The note will not be displayed on the plot, but will be saved in the data file. It allows you to put additional comments about the data and is well-suited for a brief description of the purpose and conditions of the experiment.

Read

Use this command to read data from file.

Save

Use this command to save data to file. XY titles, units, header, and note will be saved along with the data.

Calculate

Use this command to calculate the slope, intercept and correlation coefficient of the standard addition curve. If the unknown peak height is given, the unknown concentration will also be calculated.

Plot

Use this command to plot the standard addition curve. The plot will be automatically scaled according to the data range. To freeze the scale, please use the Graph Option command.

8.3 Data Report command

This command opens the Data File Report dialog box.

Use this command to generate a report for stored data files. Options are available to specify peak potential windows, slope/intercept of calibration curves, destination file name, etc.

The Data File Report command presents this dialog box.

	Species 1	Species 2	Species 3	Species 4
Species:	Cu	Pb		
Ep From (V):	-0.2	-0.35	0	0
Ep To (V):	-0.35	-0.52	0	0
Slope:	2.279e-9	2.285e-9	0	0
Intercept:	1.652e-8	3.825e-9	0	0

Peak Shape: Gaussian
 Data Type: Original
 Number of Species: 2
 Concentration Unit: ppb
 Report Filename: ww16n
 Report Data Type: Conc. Current
 Header: Waste Water Batch #16
 Note:

The following options allow you to specify peak potential windows, slope/intercept of calibration curves, and select the data files to be reported:

Compound

Enter the names of the species to be analyzed. Up to four compounds can be searched and reported.

Ep From and Ep To

Enter the peak potential range. Ep From and Ep To cannot be equal. When the program searches for peaks, the first peak in the specified range will be selected. Ranges should not overlap for different species.

Slope

Enter the slope of the calibration curve for each species to calculate the concentration of the compound. A value must be specified for each species. The program will warn the user if Conc. Data Type is selected and a slope is zero.

Intercept

Enter the intercept of the calibration curve for each species to calculate the concentration of the compound. A value must be specified for each species.

Peak Shape

Select the peak shape that is most appropriate for your data. The currently available choices are Gaussian, diffusive, and sigmoidal.

Data Type

Choose between original data, semi-derivative, and first derivative to report the concentration.

Number of Species

Enter the number of species for the data file report.

Concentration Unit

Enter the units/dimension of concentration (e.g., ppm or M).

Report Filename

Enter the report filename if you want to save the report text file. If a file with the specified name already exists, an overwrite warning will be issued. If no filename is specified, the report will be shown but not saved.

Report Data Type

Either concentration or peak current can be reported.

Header

Enter the desired title (header) for the data. To display the header on the top of the plot, check the Header box using the Graph Option command.

Note

Enter any comments about the plot. The note will not be displayed on the plot, but will be saved in the data file. It allows you to put additional comments about the data and is well-suited for a brief description of the purpose and conditions of the experiment.

Read

Use this command to read data from file.

Save

Use this command to save data to file. XY titles, units, header, and note will be saved along with the data.

Report

Use this command to generate the data file report.

8.4 Time Dependence command

This command opens the Time Dependence dialog box.

Use this command to generate a report or plot for the time dependence of peak heights or concentrations from stored data files. The program will search for peak height or concentration in each data file, sorted in chronological order relative to the earliest experiment.

The Time Dependence command presents this dialog box.

The screenshot shows the 'Time Dependence' dialog box with the following settings:

- Ep From (V): -0.2
- Ep To (V): -0.35
- Slope: 2.279e-9
- Intercept: 1.652e-8
- Peak Shape: Gaussian
- Data Type: Original
- Report Name: ww16t
- Y Axis Title: Concentration
- Y Axis Unit: ppb
- Header: Waste Water Batch #16
- Note: (empty)
- Report Data Type: Conc. Current

The following options allow you to specify peak potential windows, slope/intercept of calibration curves, and select the data files whose time dependence is to be reported or plotted:

Ep From and Ep To

Enter the peak potential range. Ep From and Ep To cannot be equal. When the program searches for peaks, the first peak in the specified range will be selected. Ranges should not overlap for different species.

Slope

Enter the slope of the calibration curve for each species to calculate the concentration of the compound. A value must be specified for each species. The program will warn the user if Conc. Data Type is selected and a slope is zero.

Intercept

Enter the intercept of the calibration curve for each species to calculate the concentration of the compound. A value must be specified for each species.

Peak Shape

Select the peak shape that is most appropriate for your data. The currently available choices are Gaussian, diffusive, and sigmoidal.

Data Type

Choose between original data, semi-derivative, and first derivative to report the concentration.

Y Axis Title

Enter the desired Y axis title (e.g., Concentration or Peak Current) to be plotted.

Y Axis Unit

Enter the units/dimension of concentration (e.g., ppm or M).

Report Name

Enter the report filename if you want to save the report text file. If a file with the specified name already exists, an overwrite warning will be issued. If no filename is specified, the report will be shown but not saved.

Report Data Type

Either concentration or peak current can be reported.

Header

Enter the desired title (header) for the data. To display the header on the top of the plot, check the Header box using the Graph Option command.

Note

Enter any comments about the plot. The note will not be displayed on the plot, but will be saved in the data file. It allows you to put additional comments about the data and is well-suited for a brief description of the purpose and conditions of the experiment.

Read

Use this command to read data from file.

Save

Use this command to save data to file. XY titles, units, header, and note will be saved along with the data.

Report

Use this command to generate the time dependence report.

Plot

Use this command to generate the time dependence plot.

8.5 Special Analysis command

Currently this command is only active for TAFEL measurements. Use this command to calculate the corrosion rate from Tafel experiment results by opening the Corrosion Rate Calculation dialog box.

When TAFEL data are available, invoking the Special Analysis command presents this dialog box.

The screenshot shows the 'Corrosion Rate Calculation' dialog box. It features a title bar with a close button. The main area contains several input fields and buttons. The 'Data Segment' is a dropdown menu set to '1'. The 'Equilibrium E' field contains '0.313'. The 'Cathodic Tafel Slope Potential Range' is set from '0.153' to '0.253'. The 'Anodic Tafel Slope Potential Range' is set from '0.373' to '0.473'. Below these are four text boxes for 'Cathodic Tafel Slope' (9.995e-001), 'Anodic Tafel Slope' (5.040e+000), 'Linear Polarization R' (1.666e+005), and 'Corrosion Current (A)' (4.322e-007). On the right side, there are three buttons: 'OK', 'Cancel', and 'Help'. At the bottom right, there is a 'Calculate' button.

Data Segment

If you have more than one segment of data, you need to specify which segment of data to use in the corrosion rate calculation.

Equilibrium E

The program will automatically estimate the equilibrium potential by searching for the potential value where current is closest to zero. You can manually override this default estimate.

Cathodic Tafel Slope Potential Range

By default, the cathodic Tafel slope potential range starts at 60 mV more negative than the equilibrium potential and has a default range of 100 mV. You can manually override this default potential range.

Anodic Tafel Slope Potential Range

By default, the anodic Tafel slope potential range starts at 60 mV more positive than the equilibrium potential and has a default range of 100 mV. You can manually change this potential range.

Calculate

Once data segment, equilibrium potential, and anodic and cathodic potential ranges are properly set, click this button to calculate the cathodic and anodic Tafel slope, linear polarization resistance (in ohms), and the corrosion current (in amperes).

Chapter 9 Sim Menu

The **Setup** menu offers the following commands:

Mechanism	Set CV or IMP simulation parameters.
CV Simulate	Run CV simulation.
CV Fitting	Run CV data fitting.

9.1 Mechanism command

Select instrument models include built-in CV simulation, impedance simulation, and impedance data fitting software.

For most techniques, this command opens the Digital Simulation dialog box. However, when the A.C. Impedance technique is selected under the Setup menu, this command will instead launch the impedance simulator.

9.1.1 Digital Simulation dialog box

The Mechanism command presents this dialog box. (This section, of course, applies only when the A. C. Impedance technique is not active.)

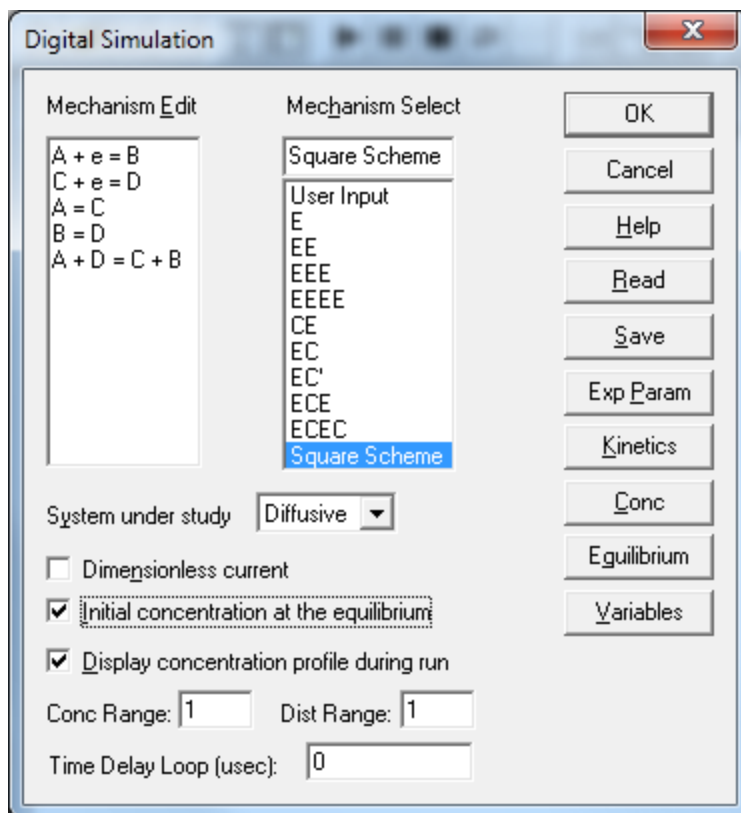

Before running a simulation, use this dialog box to set the reaction mechanism, species concentrations, kinetic, experimental, and other parameters. All settings can be saved to and read from file. The equilibrium concentration can also be checked.

Mechanism Edit

This edit box allows you to edit the reaction mechanism. The Mechanism Select list contains several pre-defined mechanisms which when clicked automatically fill out the Mechanism Edit box. Type directly in the edit box to input a user-defined mechanism (select models only).

To write your own mechanism, use a single letter (A-Z) to represent each chemical species. The letter "e" is reserved for electron transfer. The program will treat uppercase and lowercase letters as identical and ignore any spaces.

The program can simulate any reasonable combination of electron transfer, 1st order, and 2nd order chemical reactions, up to 11 reactions and 9 chemical species. Example usage:

$A + e = B$	(reduction)
$A - e = B$	(oxidation)
$A = B$	(isomerization)
$A = B + C$	(dissociation)
$A + B = C$	(combination)
$A + B = C + D$	(general reaction)

Mechanism Select

There are 10 pre-defined mechanisms covering the most commonly encountered reactions. The first item is "User Input". Only Model 630 and Model 660 will accept the user defined mechanism.

Some mechanisms not listed can still be obtained from the pre-defined mechanisms. For instance, EEC, ECC, and CEC mechanisms can be obtained from the ECEC mechanism by setting the appropriate kinetic parameters to null. If you define the heterogeneous electron transfer rate k_0 to zero, the corresponding electron transfer step will have no effect. If you define the forward and reverse rate constants of a chemical reaction to zero, the corresponding chemical reaction will have no effect.

Clicking on a pre-defined reaction mechanism will automatically fill out the Mechanism Edit box. If "User Input" is selected, the Mechanism Edit box will be empty.

System under study

A diffusive or adsorptive system can be simulated. For diffusive systems, planar diffusion is assumed. For adsorptive systems, it is assumed that the adsorption obeys the Langmuir isotherm, and both oxidized form and reduced form are strongly adsorbed.

Dimensionless current

When this box is checked, the program will calculate the dimensionless current, which is useful for comparison with other theoretical predictions. When this box is not checked, current will be calculated according to the concentration, electrode area, and time scale of the experiment.

Initial Concentration at the equilibrium

When this box is checked, the program will first calculate equilibrium concentrations and then use the computed values as the initial conditions for the simulation. The equilibrium state is calculated according to the kinetic parameters and input concentrations. When this box is unchecked, the program uses input concentrations as initial condition.

Display concentration profile during run

When this box is checked, the program will display the concentration profile along with the voltammogram during the simulation. This is very helpful to understand the reaction mechanism and is ideal for teaching purposes.

For voltammograms, the current axis scale is determined by the sensitivity scale selected under the Parameters command. If the current axis scale is too high, the voltammogram will appear as a flat line. If the current axis scale is too low, the data points will be scattered everywhere. However, the post-run data display will always autoscale the voltammogram to maximize readability. The sensitivity scale can be adjusted for the next simulation run according to the post-run display.

For concentration profiles, relative concentrations and relative distances are used. The total concentration of all involved species is set to unity by default, and all concentrations during simulation are scaled relative to this value. The unit distance is set to $6\sqrt{Dt}$ by default, where D is the diffusion coefficient and t the total time involved in the given experiment. To change the scales for concentration and distance from these default values, see the two sections below.

Conc. Range

Enter the scale factor for displaying the concentration profile. The range is 0.001 - 100000, and the default is 1.

Dist. Range

Enter the scale factor for displaying distances. The range is 0.001 - 10, and the default is 1.

Time Delay Loop

The execution time of the simulation depends on the problem you want to study and the type of computer used. When the execution time is too short, you may not be able to visualize changes in the concentration profile clearly. The Time Delay Loop variable allows you to slow the simulation down for such visualization purposes, by inserting a delay of this value between the computation of two points. The range of this parameter is from 0 to 1e6. The appropriate value will depend on the problem you want to study and the speed of your PC.

Read/Save

You can read from/save to *.sim files that contain all the parameters needed for simulation.

On clicking the Read/Save button, the program displays an Open/Save As dialog box so you can select/name your file.

Exp. Param

Click this button to set experimental parameters. Alternatively, use the Parameter command under Setup menu.

The system displays the Cyclic Voltammetry Simulator Parameters dialog box so you can select the parameters you want to use.

Kinetics

This button allows you to enter the electron transfer kinetic parameters, such as standard heterogeneous rate constant, the standard redox potential, the charge transfer coefficient. It also allows you to enter the forward and backward rate constant for chemical reactions.

The system displays the Potentials and Rate Constants dialog box so you can enter the kinetic parameters.

Conc

This button allows you to enter the diffusion coefficient and concentration of all chemical species in the system. Clicking this button displays the Concentration and Diffusion Coefficients dialog box for diffusive systems or the Surface Concentration dialog box for adsorptive systems.

Equilibrium Command

This button allows you to view the concentration of each involved chemical species under the given kinetic conditions. Clicking this button displays the Concentration at Equilibrium dialog box so you can view the equilibrium state.

Variables Command

This button allows you to specify values for other parameters, such as temperature and electrode area. Clicking this button displays the Simulation Variables dialog box so you can enter values for the appropriate variables.

9.1.2 Potentials and Rate Constants dialog box

This dialog box allows you to enter the kinetic parameters for CV simulations.

Potentials and Rate Constants						
Reactions						
A + e = B	ko	0.01092	Eo	-0.2	alpha	0.5
C + e = D	ko	0.01092	Eo	-0.49566	alpha	0.5
A = C	kf	7.78867	kb	0.3894		
B = D	kf	7.788e-006	kb	Determined		
A + D = C + B	kf	778800	kb	Determined		

All steps of the reaction mechanism are listed on the left. Depending on the type of reaction, up to 3 parameters can be specified on the right.

For charge transfer reactions, you should enter the heterogeneous rate constant k_o , the standard redox potential E_o , and the charge transfer coefficient, α .

For other chemical reactions, forward and backward rate constants should be specified.

Certain kinetic parameters may be "predetermined". This is because the concentrations of n species can be determined by $n-1$ reactions plus the initial conditions. It is often the case that there are more equations than the number of species, and hence some of the equations must be linearly dependent. In this case, The equilibrium constants of the reactions are overdetermined, and if they are all be assigned arbitrarily, the system will never reach equilibrium.

The software will automatically detect this situation and properly assign the linearly dependent kinetic parameters. You should put the reactions whose kinetic parameters are not well known on the bottom of the mechanism list and let the program automatically assign their values.

If an overdetermined equilibrium constant involves a chemical reaction, the backward rate constant will be determined by the program. You should still enter the forward rate constant.

For charge transfer reactions, the standard redox potential will be determined by the program. You should still enter the heterogeneous rate constant and α .

9.1.3 Concentration and Diffusion Coefficients dialog box

This dialog box allows you to specify the concentration and diffusion coefficients for CV simulations.

Reactions	Species	Conc/M	D/(cm2/s)
A + e = B	A:	0.001	1e-005
C + e = D	B:	0	1e-005
A = C	C:	0	1e-005
B = D	D:	0	1e-005
A + D = C + B			

All steps of the reaction mechanism are listed in the first column. The second column lists all species in the system. In the right two columns, you can enter the concentration and diffusion coefficient for each species.

9.1.4 Surface Concentration dialog box

This dialog box allows you to specify the surface concentration for CV simulations.

Reactions	Species	Conc/(mol/cm2)
A + e = B	A:	1e-10
C + e = D	B:	0
A = C	C:	0
B = D	D:	0
A + D = C + B		

All steps of the reaction mechanism are listed in the left column. The middle column lists all species in the system. In the right column, you can enter the surface concentration for each species.

9.1.5 Concentration at Equilibrium dialog box

This informational dialog box allows you to view the equilibrium concentrations computed by the CV simulator.

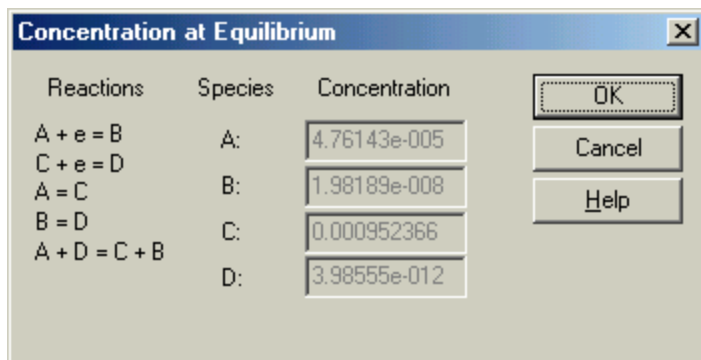

All steps of the reaction mechanism are listed on the left. The equilibrium concentration of each species is displayed on the right.

9.1.6 Simulation Variables dialog box

This dialog box allows you to specify selected CV simulation parameters:

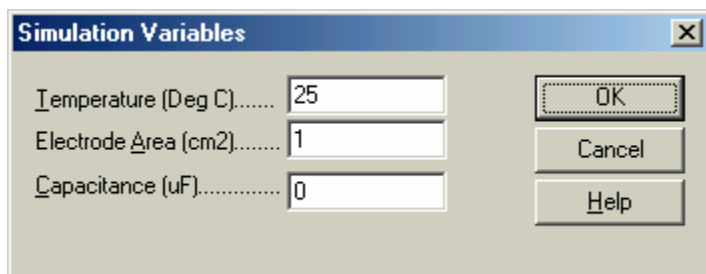

Temperature

Enter the temperature in Celsius here. Both thermodynamic and kinetic parameters depend on temperature.

Electrode Area

Enter the area of the electrode in square centimeters here. The current is proportional to the electrode area in planar diffusion situations and surface reactions.

Capacitance

Enter the electrode double layer capacitance in microfarads here. Charging currents will be added to the total current reported during the simulation.

9.2 CV Simulate command

Use this command to generate simulated CV data.

The reaction mechanism, concentrations, kinetic parameters, and experimental parameters must be first set with the Mechanism command before the simulation is run.

In order to do simulation, make sure the instrument is correctly connected to your PC, e.g. by running the Self Test command. The program will check for the proper instrument model. It only needs to check once after the program is started. After the first fit, you do not need to have the instrument connected anymore.

You can copy the screen graphics to the clipboard during the simulation.



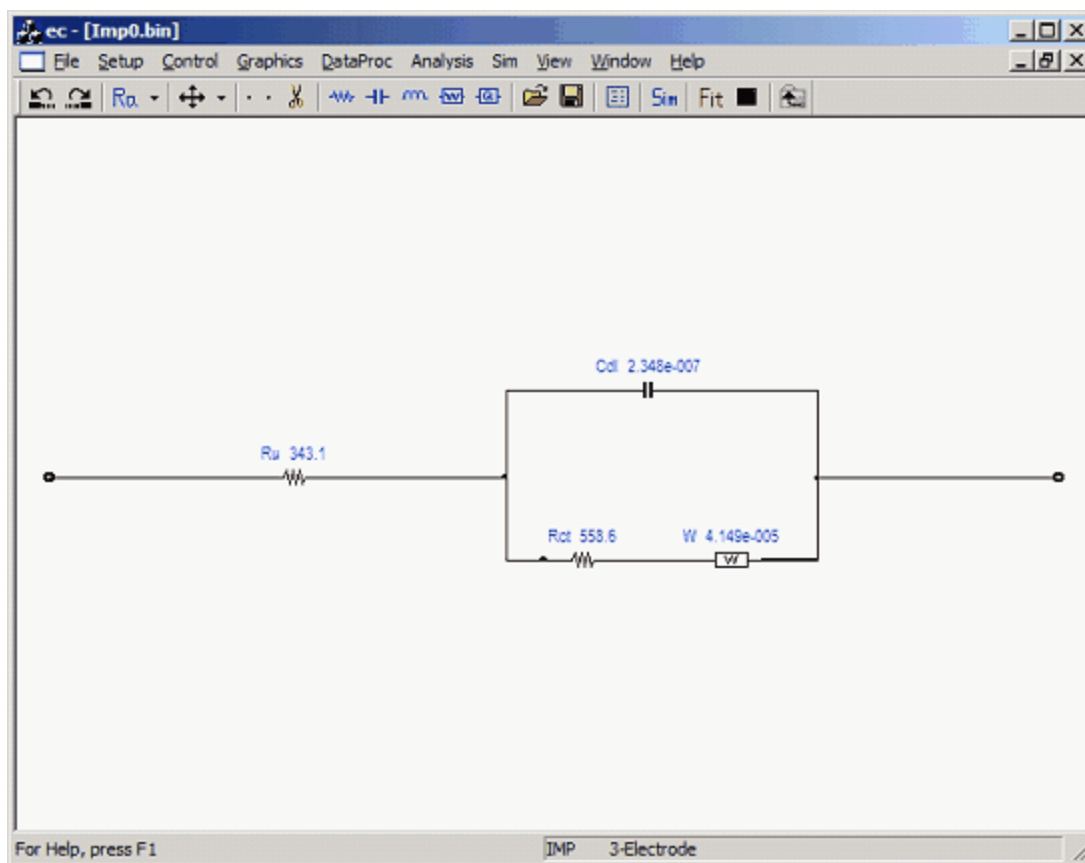

9.3 AC Impedance Simulator and Fitting Program

An impedance simulator is integrated into the program. To use the impedance simulator, you need to set Technique to AC Impedance (IMP) and then use the Mechanism command to enter the equivalent circuitry.

Once the Mechanism command has been invoked, the original toolbar will be replaced by a new one containing symbols for components and commands.



- Undo previous action.
- Redo previous action.
- Rearrange components.
- Move components left, right, up, or down.
- Clear all components.
- Cut (remove) circuit element or connection.
- Add resistor (Ohms).
- Add capacitor (Farads).
- Add inductor (Henries).
- Add Warburg impedance.
- Add constant phase element.
- Add Cole-Cole impedance.
- Add Cole-Davidson impedance.
- Add Finite Length Diffusion impedance.
- Add Open Finite Length Diffusion impedance.
- Add Gerischer impedance.
- Change simulation parameters (e.g., frequency range).
- Open equivalent circuit file for simulation or fitting.

-  Save current equivalent circuit.
-  Run impedance simulator.
-  Run impedance fitting program.
-  Stop fitting in progress.
-  Exit mechanism editor simulation environment.

Circuit Editor

The equivalent circuit editor is fully graphical. To add a circuit element, click the appropriate symbol on the toolbar and click in the main window to place the component. Double-click the component to specify the name and value of the circuit element.

Connect two elements by moving the cursor to the left or to the right of an element. When the mouse cursor is close to the left or right side of an element, a black dot will appear. Left-click and drag the mouse cursor to the left or right of the other element, releasing the left mouse button when a black dot appears on beside the other component. The two elements will now be connected.

To remove a circuit element or connection wire, left-click to select it. The color of the element or wire will change to red. Click the Cut button on the toolbar to remove the element or wire. When an element is deleted, all of its connections are deleted with it. You can also remove a component by left-clicking it and dragging it out of the window.

To move elements and wires, left-click and drag, releasing the left mouse button at the desired location in the window. Alternatively, use the Move button on the toolbar to move all components left, right, up, or down.

To rearrange components and connection wires automatically, click the Rearrange button on the toolbar. However, there are only four modes and they may not create an ideal diagram. You may have to redraw the diagram manually.

To finish the equivalent circuit drawing, you need to connect to the two big dots on the left and the right sides of the window. If you do not connect these two dots, the program will be unable to determine the two terminals of your circuit and to start the simulation.

Other potentially useful toolbar buttons have been included to: undo or redo your actions; remove all components and connection wires; save your equivalent circuit drawing to file and read it back later; and change the impedance simulation parameters, such as frequency range and number of data points per decade of frequency.

Simulation and Fitting

Please notice that the equivalent circuit you draw can be used for both simulation and fitting.

To perform a simulation, click the Sim button; the program will close the circuit editor in order to display the simulated data on the screen. Warning: unsaved data will be erased when a new simulation starts. Save your existing data before starting a simulation.

Data fitting requires an equivalent circuit as well as a set of impedance data, obtained from impedance measurements or even from a preceding simulation. A poor fit may indicate an equivalent circuit that is a poor approximation to your physical system. You may need to revise your proposed equivalent circuit to obtain a better fit.

The fitting program has known limitations. Sometimes, a poor fit will be obtained even with a known (simulated) data set. Results may also depend on the initial values of the components. If you experience problems, please send the data to info@chinstruments.com. We will try to study and improve it, but cannot guarantee better results. Efficient fitting algorithms are difficult and complicated to obtain.

Click the Fit button on the toolbar to start the fitting process. During fitting, the elapsed time, fitting error, and evolution of circuit element parameters will be displayed. The fitting process is complete when the component values have converged; the resulting values value of circuit elements as well as fitting error will be displayed. To stop the fitting process, click the Exit button on the toolbar. The original and fitted data will be overlaid and displayed.

To exit the circuit editor and return to the main program, click the Exit button.

Notes

Before you run the fitting program, make sure the instrument is correctly connected to your PC, e.g. by running the Self Test command. The program will verify that your instrument model is supported. This check only needs to be performed once after the program is started. After the first fit, you do not need to have the instrument connected anymore.

When carrying out impedance simulation and fitting, do not run other techniques or read data files other than impedance measurements. Otherwise the circuit editor may not function correctly.

Circuit Element Notation and Ranges

Circuit Element	Abbrev.	Units	Range
Resistor	R	Ohm	0.001 to 1e12
Capacitor	C	Farad	1e-12 to 1
Inductor	L	Henry	1e-12 to 1
Warburg Impedance	W	Siemens sec ^{1/2}	1e-6 to 1
Constant Phase	Q	Siemens sec ⁿ	1e-12 to 1000
Cole-Cole	CC	Ohm	0.001 to 1e12
Cole-Davidson	CD	Ohm	0.001 to 1e12
Finite Layer Diffusion	FD	Siemens sec ^{1/2}	Y _o = 1e-12 to 1e12 d/vD = 1e-6 to 1000
Open Finite Layer Diffusion	OFD	Siemens sec ^{1/2}	Y _o = 1e-12 to 1e12 d/vD = 1e-6 to 1000
Gerischer Impedance	GI	Siemens sec ^{1/2}	Y _o = 1e-12 to 1e12 k = 1e-12 to 1e12

Circuit Element Properties

Element	Impedance	Conductance	Phase
R (resistor)	$Z_R = R$	$Y_R = 1/R$	$\varphi = 0$ (frequency-independent)
C (capacitor)	$Z_C = -j/\omega C$	$Y_C = j\omega C$	$\varphi = \pi/2$
L (inductor)	$Z_L = j\omega L$	$Y_L = -j/\omega L$	$\varphi = -\pi/2$
W (Warburg)	$Z_W = (j\omega)^{-1/2}/Y_o$	$Y_W = (j\omega)^{1/2} Y_o$	$\varphi = \pi/4$
Q (phase)	$Z_Q = (j\omega)^{-n}/Y_o$	$Y_Q = (j\omega)^n Y_o$	$\varphi = n\pi/2, 0 < n < 1$
CC (Cole-Cole)	$Z_{CC} = R / [1+(j\omega\tau)^\alpha]$	$Y_{CC} = [1+(j\omega\tau)^\alpha] / R$	$\tan \varphi = (\omega\tau)^\alpha \sin(\alpha\pi/2) / [1+(\omega\tau)^\alpha \cos(\alpha\pi/2)]$
CD (Cole-Davidson)	$Z_{CD} = R / (1+j\omega\tau)^\alpha$	$Y_{CD} = (1+j\omega\tau)^\alpha / R$	$\tan (\varphi/\alpha) = \omega\tau$
FD (Finite Layer Diffusion)	$Z_{FD} = 1/Y_{FD}$	$Y_{FD} = Y_o \sqrt{j\omega} \tanh[\delta \sqrt{j\omega/D}]$	$\tan (\varphi) = \arg (Y_{FD})$
OFD (Open Finite Layer Diffusion)	$Z_{OFD} = 1/Y_{OFD}$	$Y_{OFD} = Y_o \sqrt{j\omega} \coth[\delta \sqrt{j\omega/D}]$	$\tan (\varphi) = \arg (Y_{OFD})$
GI (Gerischer Impedance)	$Z_{GI} = 1/Y_{GI}$	$Y_{GI} = Y_o \sqrt{k + j\omega}$	$\tan (\varphi) = \arg (Y_{GI})$

For more information, refer to J. R. Macdonald, *Ann. Biomed. Eng.*, 20, 289-305 (1992) or "Impedance Spectroscopy", E. Barsoukov and J. R. Macdonald, Wiley, Hoboken, 1987 (1st ed), 2005 (2nd ed).

9.4 CV Fitting command

Use this command to fit parameters to existing CV data, leveraging our built-in CV simulator to evaluate the fit (select models only).

Before you run the fitting program, make sure the instrument is correctly connected to your PC, e.g. by running the Self Test command. The program will verify that your instrument model is supported. This check only needs to be performed once after the program is started. After the first fit, you do not need to have the instrument connected anymore.

First open the CV data file you want to fit. This can be either experimental or simulated data. Using the CV Fitting command will then open the CV reaction mechanism dialog box discussed in a previous section. A judicious choice of mechanism is critical here--the numerical fitting algorithm could find an excellent fit to an incorrect mechanism, yielding unmeaningful and misleading results. The system must be specified as diffusive or a surface reaction, but kinetic parameters need not be entered.

Click OK in the Digital Simulation dialog box to bring up the CV Fitting Parameter dialog box.

This dialog box allows you to specify parameters for the CV Fitting program.

The screenshot shows the 'CV Fitting Parameter' dialog box. It features a title bar with a close button. The main area is divided into several sections. At the top left, under 'Fitting Potential Range', there are two input fields: 'Fit_ah(v)' with the value 0.254 and 'Fit_el(v)' with the value 0.142. To the right of these fields are a 'Skip' dropdown menu set to '1', an 'Error' field set to '1e-005', and 'OK' and 'Cancel' buttons. Below these is a 'Capacitance(uF)' field set to '1' with a 'Fix' checkbox. The bottom section is titled 'Potentials and Rate Constants' and shows a reaction 'A + e = B'. It has fields for 'ko' (1), 'Eo' (0), and 'alpha' (0.5), each with a 'Fix' checkbox.

The previously selected reaction mechanism and its associated potentials and rate constants will be shown. You do not need to enter kinetic parameters. A well chosen initial value may reduce the time needed for fitting, although this is not required. You can also assign and fix any kinetic parameters whose correct values are known beforehand. Checking Fix for any variable will prevent its value from being changed during the fitting process, reducing the total number of unknown variables and thus the time needed for fitting.

The initial values for the fitting potential range is determined automatically from the peak potentials, but the positive and negative limits can also be specified manually in the Fit_ah(v) and Fit_el(v) fields, respectively.

The fitting procedure will generate a fitted curve over the entire potential range, but the goodness of fit will only be measured on the Fitting Potential Range subinterval. This is because toward more extreme potentials there tend to be significant contributions from residual or background current, which are insensitive to changes in the kinetic parameters and difficult to fit accurately. The potential subinterval near the peak currents tend to be more sensitive to the kinetic parameters.

Since charging current can also make a significant contribution to CV data, the double layer capacitance is also available as a variable or constant.

Our algorithm minimizes the absolute error, defined as

$$\sqrt{[\sum_i (F_i - E_i)^2] / N},$$

where the F_i are fitted data points, E_i are your input data points, and N is the total number of data points. Absolute instead of relative error is used to avoid overweighting points for which the current nearly vanishes.

The Skip parameter allows you to omit data points from the fitting procedure, which can greatly reduce the fitting time. The Error parameter is the desired error threshold, below which the fitting procedure will end.

Click OK to start the fitting procedure.

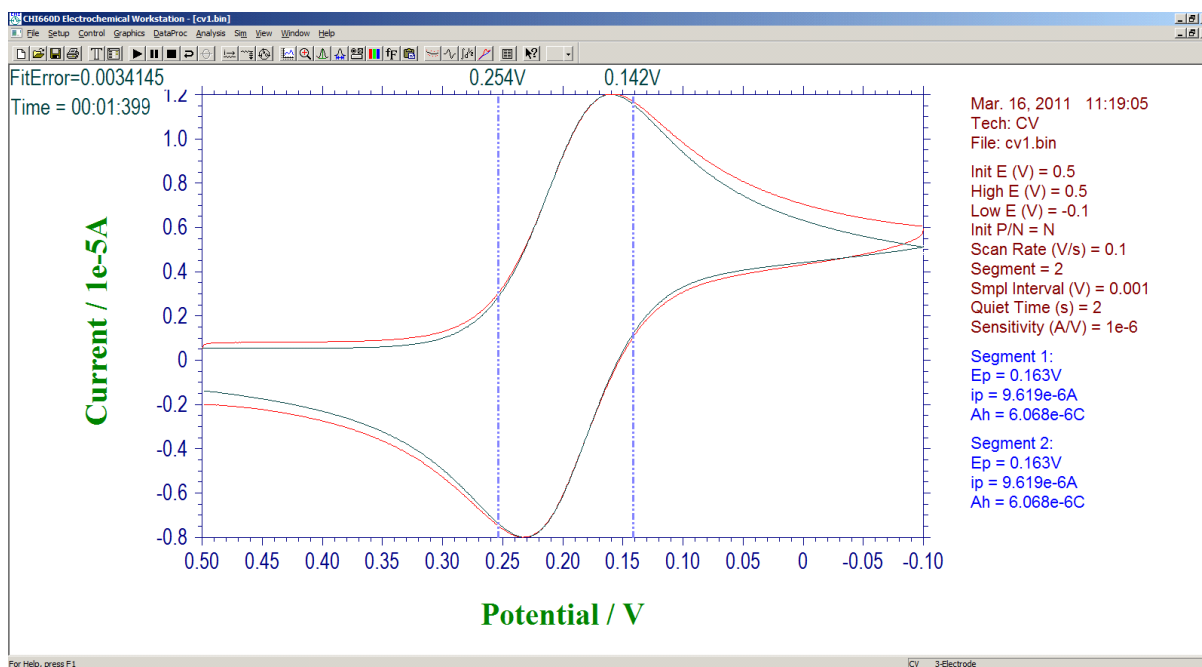

The fitting potential range will be bracketed graphically, with the fitted data plotted in green and your input data plotted in red. Fitting error and the time elapsed are also displayed in the top left. The fitting process will end when the specified Error is reached; alternatively, it can be terminated at any time by clicking the Stop button or by pressing the Esc key. The resulting fitted kinetic parameters will be then be displayed.

Chapter 10 View Menu

The **View** menu offers the following commands:

Data Information	View data information.
Data Listing	View current data as a text list.
Equations	View equations related to the selected technique.
Clock	View current date and time.
Toolbar	Shows or hides the toolbar.
Status Bar	Shows or hides the status bar.

10.1 Data Information command

This command opens the Data Information dialog box.

Use this command to view the information of the currently active data, including the date and time of the experiment, data source, and type of data processing. You can also enter your own notes about the experiment.

The Data Information command presents this dialog box.

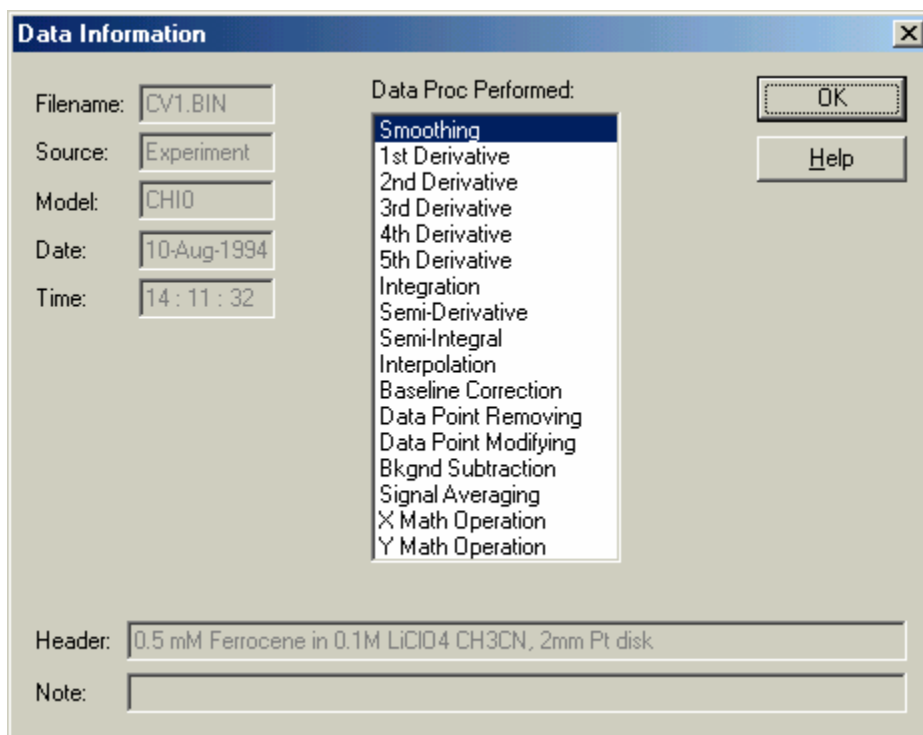

Filename

This non-editable box displays the name of the file containing the currently active data. If the data have not been stored, the filename is "Unsaved".

Data Source

This box will read either "Experiment" or "Simulated."

Model

This box displays the instrument model with which the data were acquired.

Date

This box displays the date that the data were acquired.

Time

This box displays the time that the data were acquired.

Data Proc Performed

This list box displays what types of data processing have been previously performed on the data, if applicable. If several types of data processing have been performed, multiple items will be highlighted.

Header

This box displays the optional data plot header (title).

Note

This box displays user-defined notes, and is best suited for a brief description of the purpose and conditions of the experiment/simulation.

10.2 Data Listing command

This command opens the Data List dialog box.

The format of the list can be altered by the Text File Format command under the File menu.

The Data List command presents this dialog box.

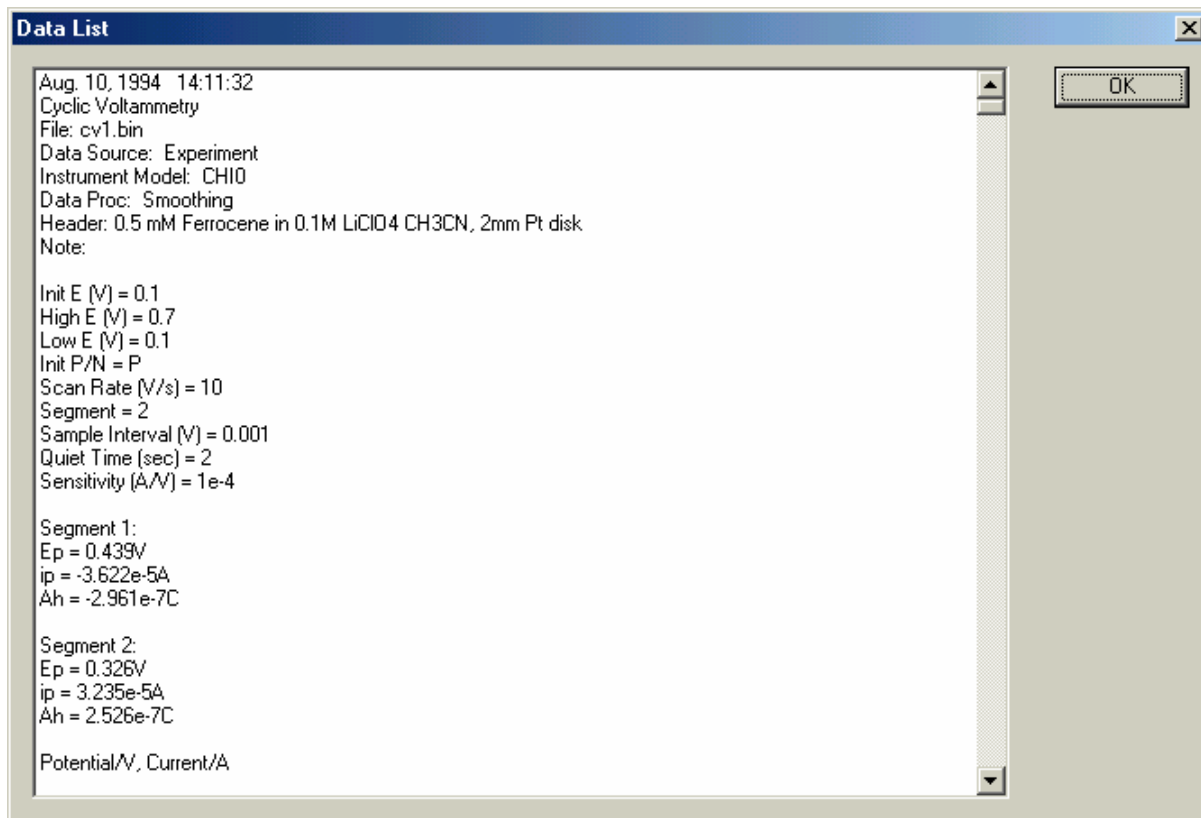

This dialog box lists the experimental conditions, results, and numerical values of the currently active data, with scroll bars if necessary. If the list is too long, the later part of the data will be truncated.

10.3 Equations command

This command opens the help browser to view equations related to the electrochemical technique currently invoked.

The following is a list of available equations. For more details about the equations and how to use them, please refer to "Electrochemical Methods", A.J. Bard and L.R. Faulkner, Wiley, New York, 1980 (1st ed), 2001 (2nd ed).

Equations

- General equations
- Symbols and Units
- Linear Sweep Voltammetry (LSV) and Cyclic Voltammetry (CV)
- Staircase Voltammetry (SCV)
- Tafel Plot (TAFEL)
- Chronoamperometry (CA)
- Chronocoulometry (CC)
- Differential Pulse Voltammetry (DPV)
- Normal Pulse Voltammetry (NPV)
- Square Wave Voltammetry (SWV)
- AC Voltammetry (ACV)
- Second Harmonic A.C. Voltammetry (SHACV)
- Amperometric Curve (i-t)
- Bulk Electrolysis with Coulometry (BE)
- Hydrodynamic Modulation Voltammetry (HMV)
- AC Impedance (IMP)
- Chronopotentiometry (CP)
- Potentiometric Stripping Analysis (PSA)

10.4 Clock command

This command opens the Clock dialog box.

Use this command to view the current date and time, which are refreshed constantly.

The Clock command presents this dialog box, which displays the current system date and time.

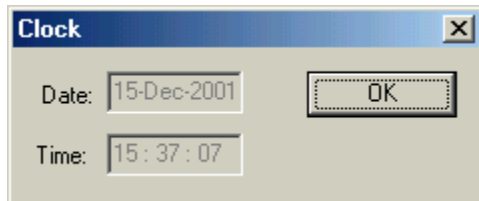

10.5 Toolbar command





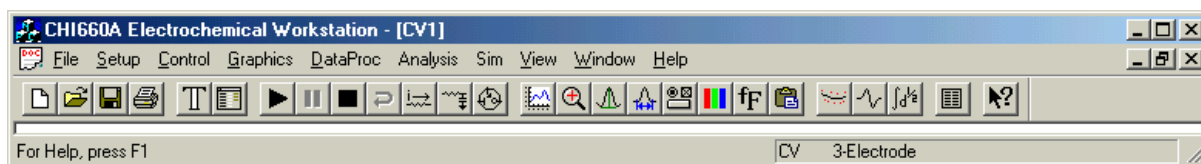





















Use this command to display and hide the toolbar, which includes buttons for some of the most common commands in the program, such as File Open. A checkmark appears next to the menu item when the toolbar is displayed.

The toolbar is displayed across the top of the application window, below the menu bar, as shown below.



The toolbar is displayed across the top of the application window, below the menu bar. The toolbar provides quick mouse access to many tools used in the program.

To hide or display the toolbar, click **Toolbar** from the **View** menu.

-  Create a new document.
-  Open an existing document using the Open dialog box.
-  Save the active document
-  Print the active document.
-  Select one of many electrochemical techniques.
-  Choose experimental parameters.
-  Start experiment.
-  Pause experiment.
-  Stop experiment.
-  Reverse CV scan direction.
-  Zero current.
-  Set and test iR compensation.
-  Set potential and current filters.
-  Set purge, stir, cleaning, and other cell conditions.
-  Plot current data graphically.
-  Increase zoom in graphics mode.
-  Report results manually.
-  Define peak or wave parameters.
-  Adjust graphics options.
-  Set color and legend in graphics.
-  Set caption font in graphics.
-  Copy graphics to clipboard.
-  Data smoothing.
-  Compute derivative.
-  Compute semi-integral and semi-derivative.
-  View current data as text.
-  Enter context-sensitive help mode (Shift + F1).

10.6 Add or Remove Buttons command

This command opens the Customize Toolbar dialog box. It is available as a drop-down arrow on the default toolbar.

There are several ways to add, remove, or reorder buttons on your toolbar. For maximum convenience, use method 1 to reorder or remove buttons, method 2 to add buttons in specified locations, and method 3 to add buttons to the right end of your toolbar. Use the Reset button in the Customize dialog box to restore the default toolbar buttons (and menus, if applicable).

1. In the main program window, while holding down the Alt key you can click on any button and drag it to a new position, or even drag it off the toolbar altogether to remove it. To add buttons, simply drag them from the Customize Toolbar dialog box onto the toolbar (direct drag-and-drop and user-customizable menus require Windows XP or higher and the corresponding edition of our software).
2. In the Customize Toolbar dialog box, drag and drop buttons to conveniently add, remove, or reorder them. That is, click on an item in the list of "Current toolbar buttons" and drag it around in the "Current" list to change its position, or drag it into the list of "Available toolbar buttons" to remove it from your toolbar. Similarly, buttons can be added from the "Available" list by dragging them into the "Current" list.
3. In the Customize Toolbar dialog box, double-click on a button in the list of "Available toolbar buttons" to add it to the toolbar. However, this will add it to the bottom of the list, and to change its position you must either drag it vertically or click the Move Up/Down button. Similarly, double-click on a button in the list of "Current toolbar buttons" to remove it from your toolbar; it will be automatically sorted into the "Available" list.
4. In the Customize Toolbar dialog box, click on the corresponding buttons to perform the desired operations. The Reset button will restore the default toolbar.

Caveats

- If your toolbar displays improperly, please restart your application.
- This command is currently not compatible with the AC Impedance simulator.
- Toolbar settings are saved locally in your ini file; as an alternative to clicking the Reset button, simply delete your ini file to restore the default toolbar. Beware that manually editing the ini file may result in unexpected behavior.

10.7 Status Bar command

Use this command to display and hide the status bar, which describes the action to be executed by the selected menu item or pressed toolbar button, and keyboard latch state. A checkmark appears next to the menu item when the status bar is displayed.



The status bar is displayed at the bottom of the program window. To display or hide the status bar, use the **Status Bar** command in the **View** menu.

The left area of the status bar describes actions of menu items as you use the arrow keys to navigate through menus. This area similarly shows messages that describe the actions of toolbar buttons as you press them, before releasing them. If after viewing the description of the toolbar button command you wish not to execute the command, then release the mouse button while the pointer is off the toolbar button.

The right area of the status bar indicates the currently active technique.

Chapter 11 Help Menu

The **Help** menu offers the following commands, which provide you assistance with this application:

Help Topics
About

Offers you an index to topics on which you can get help.
Displays the version number of this application.

11.1 Help Topics command

Use this command to display the opening screen of help. From the opening screen, you can jump to step-by-step instructions for using the program and various types of reference information.

Once you open help, you can click the **Home** button whenever you want to return to the opening screen.

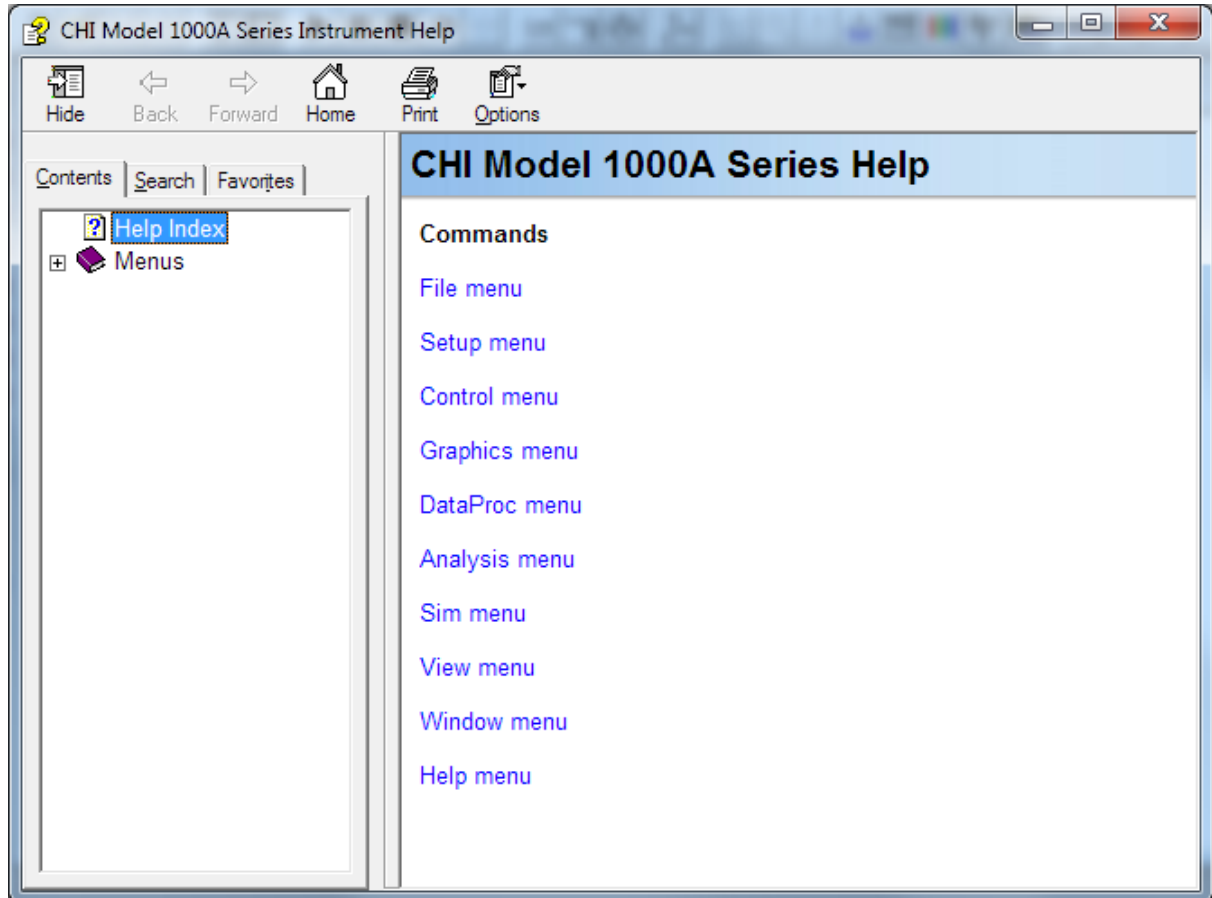

Context-sensitive help is available for the pull-down menus and the buttons on the toolbar. Press Shift+F1 to activate context-sensitive help (the mouse pointer will change to an arrow and question mark), and click on a menu command, toolbar button, or other part of the application window to learn more about it.

11.2 About command

Use this command to display the copyright notice, version number, software revision date, and manufacturer's contact information.



Chapter 12 Appendix

This chapter contains technical details, safety information, and an overview of our full line of electrochemical instrumentation. More information about the latter is also available on our website at www.chinstruments.com.

- Cables and Connections
- Firmware Update Instructions
- Troubleshooting
- Maintenance and Service
- Limited Warranty
- Safety
- Abbreviations
- Model 400B Series Time-Resolved Electrochemical Quartz Crystal Microbalance
- Model 600E Series Electrochemical Analyzer
- Model 700E Series Bipotentiostat
- Model 800C Series Electrochemical Detector
- Model 920D Scanning Electrochemical Microscope
- Model 1000C Series Multi-Potentiostat
- Model 1100C Power Potentiostat / Galvanostat
- Model 1200B Handheld Potentiostat / Bipotentiostat
- Pico-Liter Solution Dispenser
- Picoamp Booster/Faraday Cage and Multiplexer
- Amp Booster and Liquid/Liquid Interface Adapter
- Accessories

12.1 Cables and Connections

Electrode connection (round connector)

<u>Pin</u>	<u>Function</u>	<u>Color (if applicable)</u>
1	Working electrode	Green
2	Reference electrode	White
3	Counter electrode	Red
4	Analog Ground	
5	NC	
6	Sensing electrode*	Black

* This electrode is used for 4-electrode configuration, which can be used for liquid/liquid interface measurements. In this case, the red and white clips are respectively connected to the counter and reference electrodes in phase I, and the green and black clips are respectively connected to the counter and reference electrodes of phase II.

The 4-electrode configuration also helps to eliminate contact resistance (due to clips, connectors, and switching relay) and the resistance of circuitry traces, which is very important for large current (> 100 mA) measurements and low impedance cells (< 1 ohm). However, it is not recommended for low current measurements (< 20 mA) or high impedance cells.

To use 4-electrode configuration, please check the "4-Electrode" option using the Cell command under the Control menu. If you are using the 4-electrode configuration to eliminate contact resistance, you should connect the sensing electrode together with the working electrode.

When not using 4-electrode configuration, please make sure that the "4-Electrode" box in the Cell Control dialog box is unchecked. Otherwise noise and other problems may occur.

When using 3-electrode configuration, please leave the Sensing electrode unconnected.

RDE Control Connection (Banana jacks)

Red	Signal
Black	Analog Ground

Signal Output on Rear Panel (9-pin D connector)

1	Current 1 Output***
2	Reserved for Current 2 Output (bipotentiostat)
3	Potential Output
4	External Signal Input*
5	External Potential Input**
6	Ground
7	Ground
8	Ground
9	Ground

* The input voltage range is 10 V, and the input impedance of the input stage is 10K ohms. For signals with high voltages, a resistor divider should be used. For signals with a small voltage range (< 0.1 V), it is possible to amplify the signal by a factor of 10 or 100; please contact info@chinstruments.com for details.

** The external potential input is disabled by default. To enable it, you need to change a jumper setting inside the instrument. Please contact info@chinstruments.com for details.

*** Current can be calculated as: Current Output Reading (V) * sensitivity (A/V)

Com Port connection (DB-25 connector)

<u>Pin</u>	<u>Function</u>
2	Receive

3 Transmit
7 Digital Ground

Cell Control connection (DB-25 connector)

<u>Pin</u>	<u>Function</u>
1	
2	
3	
4	Analog Ground
5	-15 V (< 20 mA load)
6	+5 V (< 100 mA load)
7	Digital Ground
8	Stir (active level can be set in Cell Control)
9	Knock (active low pulse)
10	External Device Sense 1
11	External Device Sense 2
12	External Device Control 1
13	External Device Sense 3 (external trigger input, TTL signal, active low)
14	Reserved
15	Reserved
16	
17	+15 V (< 20 mA load)
18	
19	External Device Control 2
20	External Device Control 3
21	Purge (active low level)
22	
23	External Device Control 4
24	External Device Control 5
25	Reserved

The Cell Control port can be used to control stir, knock, and purge. Please check the manual of your cell stand for compatibility. Customized jumper settings or connection cables might be needed.

12.2 Firmware Update Instructions

The instrument is controlled using software on the PC side, and updates will often be as straightforward as replacing `chi####.exe` with a newer version. Occasionally, however, the instrument firmware will also need to be updated.

The instrument firmware is now stored in flash memory, allowing it to be distributed electronically rather than through the inconvenient mailing of an EPROM chip. Software and firmware are both available from info@chinstruments.com. Software installation is described in Chapter 2 of this User Manual. Firmware updates are distributed in the form of a hexadecimal file (`chi####.hex`, where `####` is the model number). To initiate a firmware update, use the Update Instrument Program command under the File menu to bring up the following dialog box:

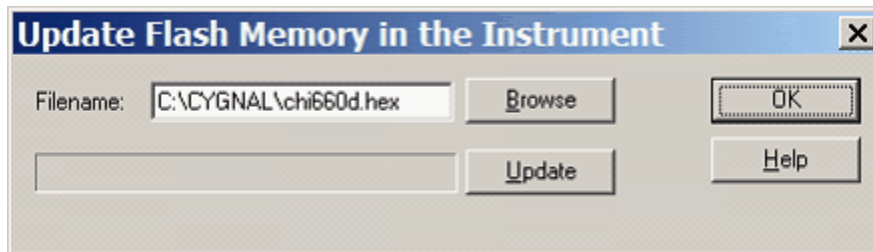

Click the Browse button to select the appropriate hex file, or type its name and full path in the Filename field.

Click the Update button to upload the hex file to the instrument flash memory. During the upload, please be patient and wait. Please do not activate any other program, and as when updating the firmware/BIOS of any piece of electronics, do not interrupt power to either the PC or the instrument. Any of these actions could cause the upload to fail and corrupt the flash memory, rendering the instrument unusable short of force programming back at the factory. Please contact CH Instruments, Inc. at info@chinstruments.com if this event should occur.

If the upload does not succeed, you will get an error message. In this case, turn the instrument off for 5-10 seconds, then turn it back on. You may need to exit and restart the PC program before trying again.

If the upload is successful, you will get a confirmation message. The updated instrument is now ready to use.

12.3 Troubleshooting

Problem	Possible Cause	Action
Link failed	Power is not on	Power on the instrument
	Cable is disconnect	Connect the instrument to the computer
	Faulty cable	Check and change cable
	COM port setting does not match port in use	Change settings using System command under Setup menu
	Computer problem	Remove network/modem cards if present; if problem persists, try other computers
Unresponsive mouse	Static discharge	Reset instrument and computer
	Lengthy computation process	Wait for computation to complete
Windows application error	Communication failed	Reset instrument and computer
		Restart program or reset the computer
Hardware test error		Repeat hardware test and report error message to info@chinstruments.com
No current response	Electrode leads disconnected or broken	Check electrode leads
Noisy data	Unreliable data transfer	If data reading exceeds $10 \times$ sensitivity scale, the problem could be related to the COM port; remove network/modem cards if present or try other computers
	Reference electrode impedance too high	Check for trapped air bubble at reference electrode tip; use reference electrode with Vycor tip
	Electrically noisy environment	Use Faraday cage; see Useful Tips section in Chapter 2
	Instability of potentiostat due to large double layer capacitance	Use Cell command under Control menu to manually turn on stabilizing capacitor
	Weak signal	Increase sensitivity scale; adjust filters
Data out of range	Computer problem	Remove network/modem cards if present or try other computers
	Sensitivity scale too high	Lower sensitivity scale
Overflow warning during experiment	Hardware problem	Use Hardware Test command under Setup menu to test hardware
	Sensitivity scale too high	Lower sensitivity scale
Y-axis title rotated incorrectly	Printer driver incompatibility	Use Font command under Graphics menu to toggle Y-axis title rotation
Unreasonable default conditions	Incompatible configuration (.cfg or .ini) file	Delete old configuration files; new files will be generated automatically
Simulation program does not run	Instrument not found	Connect and power on the instrument
	User input mechanism unavailable for this instrument model	Use a pre-defined mechanism

12.4 Maintenance and Service

The recommended operating temperature is 15 - 28°C.

Since the instrument is a sophisticated piece of equipment, you should not try to service it yourself. If it is not working properly, please run the hardware test and contact the factory for service.

12.5 Limited Warranty

This CH Instruments product is warranted against defects in workmanship and material. If any failure resulting from a defect of workmanship or material shall occur under normal use within one year from the date of purchase shown on the purchase receipt, CH Instruments, Inc. will, at its option, either repair the defective product without charge for parts and labor, or provide a replacement in exchange for the defective product.

In order to obtain service under this warranty, the customer must notify CH Instruments, Inc. before the expiration of the warranty period and make arrangements for service. The customer shall be responsible for packing and shipping the defective product with prepaid shipping charges. CH Instruments, Inc. will pay for return shipping of the repaired or replacement product to the customer within the United States. The customer shall be responsible for all shipping charges, duties, taxes, and other charges for products sent outside of the United States.

Warranty service does not cover failures caused by misuse, accident, modification, unsuitable physical or operating environment, improper maintenance, or service of the product by unauthorized personnel.

In no event shall CH Instruments, Inc. be liable or in any way responsible for any lost profits, lost savings, incidental, or other financial consequential damages. This is true even if you advise CH Instruments, Inc. of the possibility of such damages.

12.6 Safety

Section 1: LVD Notes for manual safety issues and protection of instrument against damage

1. The unit described in this manual is designed to be operated by trained personnel with a reasonable background knowledge of electrochemistry. Any adjustments, maintenance, or repairs must be carried out as defined by this manual (please refer to Appendix sections above) by a qualified person aware of the hazards involved.

2. (a) It is essential that operating personnel follow safe working procedures, in addition to the detailed instructions specified in this manual.

2. (b) The instrument should be placed in a position where the likelihood of the ingress of a chemical spill is kept to an absolute minimum. Efforts should also be made to avoid contact of the instrument with, for instance, corrosive vapours. The electrochemical cell should not be placed on top of the unit due to the risk of leakage and the possibility of the cell contents entering the instrument. If chemicals do enter the unit, switch it off immediately and contact the nearest dealer/CH Instruments, Inc. (contact details at the front of this manual). Routine cleaning of the chassis of the instrument is not necessary. A spill onto the outer casing that does not enter the instrument should be wiped off with a dry cloth, making sure to wipe away from any instrument connections. Likewise, the PC used to operate the instrument should be protected from possible exposure to chemicals.

2. (c) Despite the customer's best efforts, corrosion of the electrode leads can occur. This condition is best diagnosed by running a CV from -1 V to +1 V on a 1 M Ohm resistor, with sensitivity set to $1e-6$. An Ohmic plot through the origin should be obtained, with maximum current of $\pm 1 \mu\text{A}$. Working contacts (green and black) are connected to one side of the resistor and counter (aux) and reference (red and white) to the other. Noticeable divergence from this behavior (i.e., linearity through the origin) may suggest faulty leads.

2. (d) Erroneous data/behavior in an actual electrochemical experiment may be due to factors such as faulty cell connections, poor reference electrode contact, or poor condition of the working electrode. Reference and working electrodes are consumable items and are readily available from CH Instruments, Inc. or your local dealer (see Appendix for a description of the range of accessories available). When a customer uses his/her own electrodes, it is recommended that experimental data be compared against known standards from time to time.

3. The cover of the instrument should only be removed by qualified personnel at the direction of CH Instruments, Inc..

4. Users should always refer to the health and safety data supplied with any chemicals used. Generally accepted laboratory procedures for the safe handling of chemicals should always be employed.

5. Evidence of any fault condition should immediately be reported to CH Instruments, Inc. or the local distributor as applicable. Hardware faults are usually diagnosed through the instrument's own self test procedure (see Troubleshooting in the Appendix).

6. As the instrument requires a data connection to a PC, we recommend that sufficient space (at least 2 m of linear bench) is set aside in order to avoid cluttering the work area and to ensure easy access to the cell. There should be enough free space around the vents and fan exhaust of the instrument to prevent overheating.

7. Connections to the cell by crocodile clips should be made in such a way as to avoid shorting of the contacts.

Section 2. Power configuration

On unpacking the instrument the presence of the following should be noted.

1. Mains cable
2. Cell Lead
3. User Manual
4. Optional accessories if ordered (cells, electrodes, etc.)

The instrument is designed to operate at 110V or 220 V (+/-20%) AC power @ 50/60 Hz. Please check the rear panel label for its input voltage setting. If an incorrect AC voltage is connected, the fuse will blow and the instrument may be damaged.

The correct voltage and line frequency for your region have been set at our factory prior to shipment.

The standard 2 meter (or 6 foot) mains cable is fitted with an IEC type connector which can be plugged directly into the power input on the rear panel of your instrument. The mains fuse (250V L 0.4A) is housed within the power socket. When replacing the fuse, the user should fully disconnect the instrument from the power supply.

In the event of repeat fuse failure, the user should consult CH Instruments, Inc. before proceeding further.

The unit should be placed within 1.5 m of a grounded mains power supply.

When the instrument is powered on, the indicator light on the front panel will be illuminated.

Rear panel of instrument

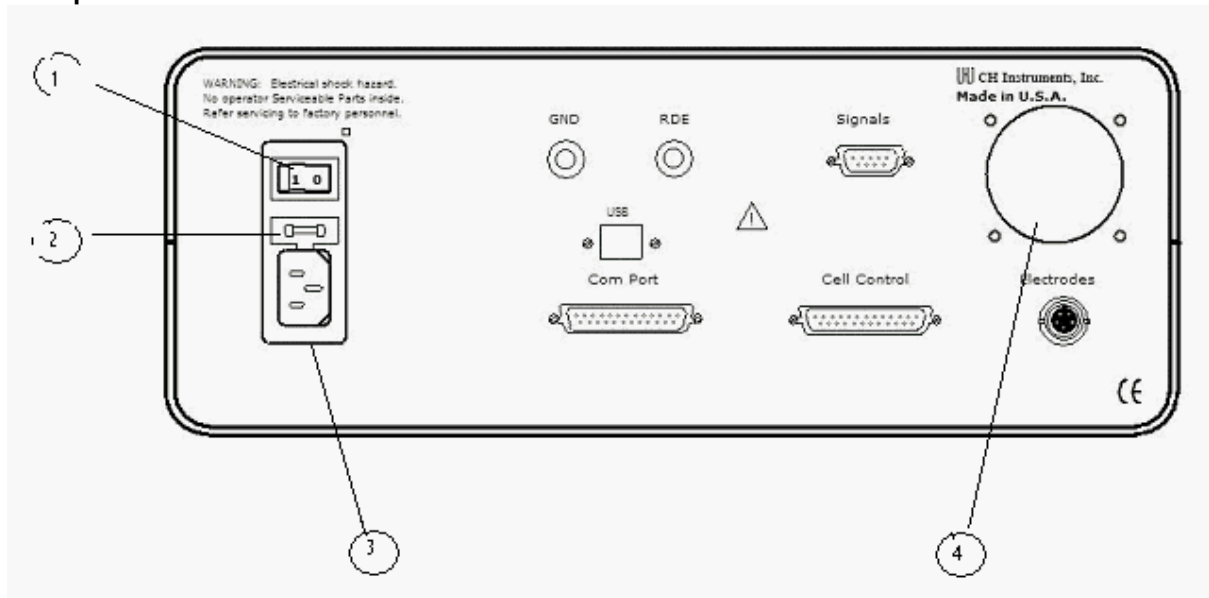

- | | |
|-----------------------|--|
| 1. Power switch | On/off switch of unit |
| 2. Fuse | State fuse value here |
| 3. Power input socket | IEC type connection socket for mains cable |
| 4. Cooling fan | |
- Fuse rating = 0.8 A for 110V AC input, 0.4 A for 230V AC input
 Power cord rating = 15 A for 110V AC input, 10 A for 230V AC input
 All other features are clearly labeled on the rear panel itself.

12.7 Abbreviations of Electrochemical Techniques

ACV	AC Voltammetry (including phase-selective)
BE	Bulk Electrolysis with Coulometry
CA	Chronoamperometry
CC	Chronocoulometry
CP	Chronopotentiometry
CPCR	Chronopotentiometry with Current Ramp
CV	Cyclic Voltammetry
DDPA	Double Differential Pulse Amperometry
DNPV	Differential Normal Pulse Voltammetry
DPA	Differential Pulse Amperometry
DPV	Differential Pulse Voltammetry
ECN	Electrochemical Noise Measurement
FTACV	Fourier Transform AC Voltammetry
HMV	Hydrodynamic Modulation Voltammetry
IMP	Impedance Spectroscopy
IMP-t	Impedance - Time
IMP-E	Impedance - Potential
IPAD	Integrated Pulse Amperometric Detection
ISTEP	Multi-Current Steps
i-t	Amperometric i-t Curve
LSV	Linear Sweep Voltammetry
NPV	Normal Pulse Voltammetry
OCPT	Open Circuit Potential - Time
PSA	Potentiometric Stripping Analysis
QCM	Quartz Crystal Microbalance
SCV	Staircase Voltammetry
SHACV	Second Harmonic AC Voltammetry (including phase-selective)
SSF	Sweep-Step Functions
SWV	Square Wave Voltammetry
TAFEL	Tafel Plot
TPA	Triple Pulse Amperometry

12.8 Model 400B Series Time-Resolved Electrochemical Quartz Crystal Microbalance

The quartz crystal microbalance (QCM) is a variant of acoustic wave microsensors that are capable of ultrasensitive mass measurements. For example, using our crystal, which has a fundamental frequency of 7.995 MHz, a net change of 1 Hz in oscillation frequency corresponds to 1.34 ng of mass adsorbed/desorbed onto/from a crystal surface of area of 0.196 cm².

QCM in conjunction with electrochemistry (EQCM) has been widely employed for the determination of deposited metals, studies of ion-transport processes in polymer films, biosensor development, and investigations of the adsorption/desorption kinetics of adsorbate molecules. In EQCM experiments, measurements of various electrochemical parameters, such as potential, current, and charge at the working electrode, are conducted simultaneously with the acquisition of the corresponding frequency and resistance changes, using the experimental setup shown in the Figure below. For any model in the 400B series, application of a specific potential waveform (e.g., triangular potential waveform for cyclic voltammetric experiments), current measurement, and frequency counting are carried out with a potentiostat/frequency counter, which is in turn controlled by a personal computer.

The 400B series contains a quartz crystal oscillator, a frequency counter, a fast digital function generator, a high-resolution and high-speed data acquisition circuitry, a potentiostat, and a galvanostat (Model 440B only). The QCM is integrated with the potentiostat and galvanostat to facilitate simple and convenient EQCM studies. Instead of measuring the frequency directly, the 400B series uses a time-resolved mode as follows. The observed frequency of the QCM is subtracted from a standard reference frequency, and the resulting difference is measured by a reciprocal technique, greatly reducing the required sampling time and yielding much better time resolution for the QCM signal. With direct counting, a QCM frequency resolution of 1 Hz requires 1 second of sampling time, 0.1 Hz resolution requires 10 seconds, etc. In contrast, our time-resolved mode allows the QCM signal to be measured in milliseconds with much better resolution. QCM data can be recorded for a scan rate of 1 V/s or lower.

The EQCM cell consists of three round Teflon pieces (see Figure below). The total height is 37 mm with a diameter of 35 mm. The top piece is the cell top, which holds the reference and counter electrodes. There are also two 2 mm holes for manual purging. The center piece is the solution cell, and the bottom piece is for mounting purposes. Four screws are used to tighten an O-ring seal between the bottom and center pieces, with the quartz crystal sandwiched between them. The diameter of the quartz crystal is 13.7 mm. The gold electrode diameter is 5.1 mm.

Specifications

Potentiostat
Galvanostat (Model 440B)
Potential range: -10 to 10 V
Potentiostat rise time: < 2 μ s
Compliance voltage: \pm 12 V
3- or 4-electrode configuration
Current range: 250 mA
Reference electrode input impedance: 10⁻¹² ohm
Sensitivity scale: 10⁻¹² - 0.1 A/V in 12 ranges
Input bias current: < 50 pA
Current measurement resolution: < 0.01 pA
Minimum potential increment in CV: 100 μ V
Potential update rate: 10 MHz
Data acquisition: 16 bit @ 1 MHz
Frequency resolution: < 0.1 Hz
QCM maximum sampling rate: 1 kHz
Automatic and manual iR compensation

CV and LSV scan rate: 0.000001 to 5000 V/s
Potential increment during scan: 0.1 mV @ 1000 V/s
CA and CC pulse width: 0.0001 to 1000 sec
CA and CC Steps: 320
DPV and NPV pulse width: 0.0001 to 10 sec
SWV frequency: 1 to 100 kHz
ACV frequency: 1 to 10 kHz
SHACV frequency: 1 to 5 kHz
Low-pass signal filters, automatic and manual setting
RDE rotation control output: 0 - 10 V (430B and up)
Cell control: purge, stir, knock
Data length: 128K - 4096K selectable
Chassis dimensions: 14.25"(W) \times 9.25"(D) \times 4.75"(H)
Oscillator box (external): 4.75"(L) \times 2.6"(W) \times 1.55"(H)
Weight: 12 lb.

Techniques for Model 400B Series

Technique	400B	410B	420B	430B	440B
Cyclic Voltammetry (CV)	•	•	•	•	•
Linear Sweep Voltammetry (LSV) &	•	•	•	•	•
Staircase Voltammetry (SCV) #,&				•	•
Tafel Plot (TAFEL)				•	•
Chronoamperometry (CA)	•		•	•	•
Chronocoulometry (CC)	•		•	•	•
Differential Pulse Voltammetry (DPV) #,&		•	•	•	•
Normal Pulse Voltammetry (NPV) #,&		•	•	•	•
Differential Normal Pulse Voltammetry (DNPV) #,&					•
Square Wave Voltammetry (SWV) &			•	•	•
AC Voltammetry (ACV) #,&,\$				•	•
2nd Harmonic AC Voltammetry (SHACV) #,&,\$				•	•
Amperometric I-t Curve (I-t)				•	•
Differential Pulse Amperometry (DPA)					•
Double Differential Pulse Amperometry (DDPA)					•
Triple Pulse Amperometry (TPA)					•
Bulk Electrolysis with Coulometry (BE)	•		•	•	•
Hydrodynamic Modulation Voltammetry (HMV)					•
Sweep-Step Functions (SSF)					•
Multi-Potential Steps (STEP)					•
Chronopotentiometry (CP)					•
Chronopotentiometry with Current Ramp (CPCR)					•
Potentiometric Stripping Analysis (PSA)					•
Open Circuit Potential - Time (OCPT)	•	•	•	•	•
Quartz Crystal Microbalance (QCM)	•	•	•	•	•
Galvanostat					•
RDE control (0-10V output)				•	•
Full version of CV simulator				•	•
Limited version of CV simulator	•	•	•		
iR Compensation	•	•	•	•	•

Corresponding polarographic mode can be performed.

& Corresponding stripping mode can be performed.

\$ Phase-selective data are available.

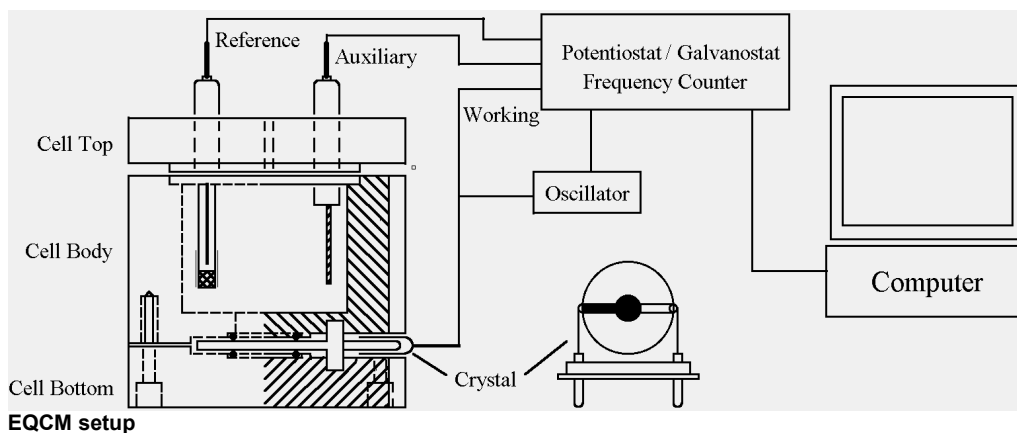

12.9 Model 600E Series Electrochemical Analyzer Techniques

Technique	600E	602E	604E	606E	608E	610E	620E	630E	650E	660E
CV
LSV &
SCV #,&								.	.	.
TAFEL	
CA
CC
DPV #,&					
NPV #,&					
DNPV #,&										.
SWV &						
ACV #,&,\$.	.	.
SHACV #,&,\$.	.	.
FTACV										.
i-t								.	.	.
DPA										.
DDPA										.
TPA										.
IPAD										.
BE
HMV									.	.
SSF									.	.
STEP									.	.
IMP		
IMP-t		
IMP-E		
CP				.	.					.
CPCR				.	.					.
ISTEP				.	.					.
PSA				.	.					.
ECN										.
OCPT

Corresponding polarographic mode can be performed.

& Corresponding stripping mode can be performed.

\$ Phase-selective data are available.

Dynamic Range of Selected Experimental Parameters

Parameter	Range	Techniques
Potential (V)	-10 to +10	
Current (A)	0 to ± 0.25 (peak ± 0.35)	
Sensitivity (A/V)	10^{-12} to 0.1	
Sampling Rate	1 MHz at 16-bit resolution	
Scan rate (V/s)	0.000001 to 10000	CV, LSV
Pulse width (sec)	0.0001 to 1000	CA, CC
Pulse width (sec)	0.001 to 10	DPV, NPV
Sampling interval (sec)	0.0001 to 10	DPV, NPV
Frequency (Hz)	1 to 100000	SWV
Frequency (Hz)	0.1 to 10000	ACV
Frequency (Hz)	0.1 to 5000	SHACV
Frequency (Hz)	0.00001 to 1000000	IMP

12.10 Model 700E Series Bipotentiostat Techniques

<i>Technique</i>	<i>700E</i>	<i>701E</i>	<i>710E</i>	<i>720E</i>	<i>730E</i>	<i>750E</i>	<i>760E</i>
CV
LSV &
SCV #,&					.	.	.
TAFEL					.	.	.
CA
CC
DPV #,&		
NPV #,&		
DNPV #,&							.
SWV &			
ACV #,&,\$.	.	.
SHACV #,&,\$.	.	.
FTACV							.
i-t	
DPA							.
DDPA							.
TPA							.
IPAD							.
BE
HMV						.	.
SSF						.	.
STEP						.	.
IMP						.	.
IMP-t						.	.
IMP-E						.	.
CP							.
CPCR							.
ISTEP							.
PSA							.
ECN							.
OCPT

Corresponding polarographic mode can be performed.

& Corresponding stripping mode can be performed.

\$ Phase-selective data are available.

Dynamic Range of Selected Experimental Parameters

<i>Parameters</i>	<i>Range</i>	<i>Techniques</i>
Potential (V)	-10 to +10	
Current (A)	0 to ± 0.25 (one channel only)	
Current (A)	0 to ± 0.125 (dual channel)	
Sensitivity (A/V)	10^{-12} to 0.1 (both channels)	
Sampling Rate	1 MHz at 16-bit resolution	
Scan rate (V/s)	0.000001 to 10000	CV, LSV
Pulse width (sec)	0.0001 to 1000	CA, CC
Pulse width (sec)	0.001 to 10	DPV, NPV
Sampling interval (sec)	0.0001 to 10	DPV, NPV
Frequency (Hz)	1 to 100000	SWV
Frequency (Hz)	0.1 to 10000	ACV
Frequency (Hz)	0.1 to 5000	SHACV
Frequency (Hz)	0.00001 to 1000000	IMP

Dual-channel measurements are available for CV, LSV, SCV, CA, DPV, NPV, SWV, and i-t.

12.11 Model 800C Series Electrochemical Detector Techniques

<i>Techniques</i>	<i>800C/802C</i>	<i>810C/812C</i>	<i>820C/822C</i>	<i>830C/832C</i>	<i>840C/842C</i>
CV
LSV &
CA				.	.
CC				.	.
DPV #,&			.	.	.
NPV #,&			.	.	.
SWV &			.	.	.
i-t
DPA		.		.	.
DDPA		.		.	.
TPA		.		.	.
BE			.	.	.
SSF					.
STEP					.
PSA (Zero Current)				.	.
CP					.
CPCR					.
ISTEP					.
OCPT

Corresponding polarographic mode can be performed.

& Corresponding stripping mode can be performed.

Dynamic Range of Selected Experimental Parameters

<i>Parameters</i>	<i>Range</i>	<i>Techniques</i>
Potential (V)	-10 to +10	
Current (A)	0 to ± 0.01	
Sensitivity (A/V)	10^{-12} to 0.001	
Scan rate (V/s)	0.000001 to 500	CV, LSV
Pulse width (sec)	0.0001 to 1000	CA, CC
Pulse width (sec)	0.001 to 10	DPV, NPV
Sampling interval (sec)	0.00005 to 10	i-t
Frequency (Hz)	1 to 100000	SWV

Single channel (8×0C) or dual channel (8×2C) electrochemical detection. High sensitivity and low noise. Fast 16-bit A/D converter (1 MHz). Bipotentiostat can also be used for RRDE.

12.12 Model 920D Scanning Electrochemical Microscope

The scanning electrochemical microscope (SECM) was introduced in 1989¹ as an instrument that could examine chemistry at high resolution near interfaces. By detecting reactions that occur at a small electrode (the tip) as it is scanned in close proximity to a surface, the SECM can be employed to obtain chemical reactivity images of surfaces and to make quantitative measurements of reaction rates. Numerous studies with the SECM have now been reported from a number of laboratories all over the world, and the instrument has been used for a wide range of applications, including studies of corrosion, biological systems (e.g., enzymes, skin, leaves), membranes, and liquid/liquid interfaces.² The trapping and electrochemical detection of single molecules by SECM has also been reported.

1. A. J. Bard, F.-R. F. Fan, J. Kwak, and O. Lev, *Anal. Chem.* 61, 132 (1989); U.S. Patent No. 5,202,004 (April 13, 1993).
2. A. J. Bard, F.-R. Fan, M. V. Mirkin, in *Electroanalytical Chemistry*, A. J. Bard, Ed., Marcel Dekker, New York, 1994, Vol. 18, pp 243-373.

Model 900D/920D SECM Specifications

Nanopositioner:

- X, Y, Z resolution: 1.6 nm with Piezo positioner, closed loop control
- 8 nm with stepper motor positioner
- X, Y, Z total distance: 50 mm

Potentiostat / Bipotentiostat:

- Zero resistance ammeter
- 2- or 3- or 4-electrode configuration
- Floating (isolated from earth) or earth ground
- Maximum potential: ± 10 V for both channels
- Maximum current: ± 250 mA continuous (sum of two current channels), ± 350 mA peak
- Compliance Voltage: ± 13 V
- Potentiostat rise time: < 1 ms, 0.8 ms typical
- Potentiostat bandwidth (-3 dB): 1 MHz
- Applied potential ranges (V): ± 0.01 , ± 0.05 , ± 0.1 , ± 0.65 , ± 3.276 , ± 6.553 , ± 10
- Applied potential resolution: 0.0015% of potential range
- Applied potential accuracy: ± 1 mV, $\pm 0.01\%$ of scale
- Applied potential noise: < 10 mV rms
- Measured current range: ± 10 pA to ± 0.25 A in 12 ranges
- Measured current resolution: 0.0015% of current range, minimum 0.3 fA
- Current measurement accuracy: 0.2% if current range $\geq 1e-6$ A/V, 1% otherwise
- Input bias current: < 20 pA

Galvanostat:

- Galvanostat applied current range: 3 nA – 250 mA
- Applied current accuracy: 20 pA $\pm 0.2\%$ if $> 3e-7$ A, $\pm 1\%$ otherwise
- Applied current resolution: 0.03% of applied current range
- Measured potential range: ± 0.025 V, ± 0.1 V, ± 0.25 V, ± 1 V, ± 2.5 V, ± 10 V
- Measured potential resolution: 0.0015% of measured range

Electrometer:

- Reference electrode input impedance: $1e12$ ohm
- Reference electrode input bandwidth: 10 MHz
- Reference electrode input bias current: ≤ 10 pA @ 25°C

Waveform Generation and Data Acquisition:

- Fast waveform update: 10 MHz @ 16-bit

Scanning Probe Techniques:

- SECM Imaging (SECM): constant height, constant current, potentiometric and impedance modes
- Probe Approach Curves (PAC)
- Probe Scan Curve (PSC): constant height, constant current, potentiometric, impedance, and constant impedance modes
- Surface Patterned Conditioning (SPC)
- Surface Interrogation SECM (SISECM)
- Z Probe Constant Current Control

Sweep Techniques:

- Cyclic Voltammetry (CV)
- Linear Sweep Voltammetry (LSV)
- Tafel Plot (TAFEL)

Step and Pulse Techniques:

- Staircase Voltammetry (SCV)
- Chronoamperometry (CA)
- Chronocoulometry (CC)
- Differential Pulse Voltammetry (DPV)
- Normal Pulse Voltammetry (NPV)
- Differential Normal Pulse Voltammetry (DNPV)
- Square Wave Voltammetry (SWV)

AC Techniques:

- AC Voltammetry (ACV)
- Second Harmonic AC Voltammetry (SHACV)
- Fourier Transform AC Voltammetry (FTACV)
- AC Impedance (IMP)
- Impedance versus Potential (IMPE)
- Impedance versus Time (IMPT)

Galvanostatic Techniques:

- Chronopotentiometry (CP)
- Chronopotentiometry with Current Ramp (CPCR)
- Multi-Current Steps (ISTEP)
- Potentiometric Stripping Analysis (PSA)

Other Techniques:

- Amperometric i-t Curve (i-t)
- Differential Pulse Amperometry (DPA)
- Double Differential Pulse Amperometry (DDPA)

- Fast data acquisition: dual channel 16-bit ADC, 1,000,000 samples/sec simultaneously
- External signal recording channel at maximum 1 MHz sampling rate

2D and 3D Graphics:

- Interactive visualization of SECM surfaces
- Color mapping
- Laplacian smoothing
- Stereoscopic 3D anaglyph imaging
- High compatibility (Windows 98, 256 colors and up)

Other Features:

- Automatic and manual iR compensation
- Current measurement bias: full range with 16-bit resolution, 0.003% accuracy
- Potential measurement bias: ± 10 V with 16-bit resolution, 0.003% accuracy
- External potential input
- Potential and current analog output
- Programmable potential filter cutoff: 1.5 MHz, 150 KHz, 15 KHz, 1.5 KHz, 150 Hz, 15 Hz, 1.5 Hz, 0.15 Hz
- Programmable signal filter cutoff: 1.5 MHz, 150 KHz, 15 KHz, 1.5 KHz, 150 Hz, 15 Hz, 1.5 Hz, 0.15 Hz
- RDE control output: 0-10V (corresponding to 0-10000 rpm), 16-bit, 0.003% accuracy
- Digital input/output lines programmable through macro command
- Flash memory for quick software update
- Serial port or USB port selectable for data communication
- Cell control: purge, stir, knock
- Maximum data length: 256K-16384K selectable
- Real Time Absolute and Relative Distance Display
- Real Time Probe and Substrate Current Display
- Dual-channel measurements for CV, LSV, CA, DPV, NPV, SWV, i-t
- CV simulation and fitting program, user defined mechanisms
- Impedance simulation and fitting program

- Triple Pulse Amperometry (TPA)
- Integrated Pulse Amperometric Detection (IPAD)
- Bulk Electrolysis with Coulometry (BE)
- Hydrodynamic Modulation Voltammetry (HMT)
- Sweep-Step Functions (SSF)
- Multi-Potential Steps (STEP)
- Electrochemical Noise Measurement (ECN)
- Open Circuit Potential - Time (OCPT)
- Various Stripping Voltammetry
- Potentiometry

Experimental Parameters:

- CV/LSV scan rate: 0.000001 to 10,000 V/s, two channels simultaneously
- Potential increment during scan: 0.1 mV @ 1,000 V/s
- CA and CC pulse width: 0.0001 to 1000 sec
- CA minimum sample interval: 1 μ s, both channels
- CC minimum sample interval: 1 μ s
- True integrator for CC
- DPV and NPV pulse width: 0.001 to 10 sec
- SWV frequency: 1 to 100 kHz
- i-t sample interval: minimum 1 μ s, both channel
- ACV frequency: 0.1 to 10 kHz
- SHACV frequency: 0.1 to 5 kHz
- FTACV frequency: 0.1 to 50 Hz, simultaneous acquire 1st, 2nd, 3rd, 4th, 5th, and 6th harmonics ACV data
- IMP frequency: 0.00001 to 1 MHz
- IMP amplitude: 0.00001 V to 0.7 V RMS

SECM Image

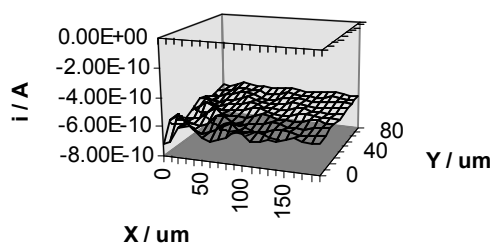

Probe Approach Curve

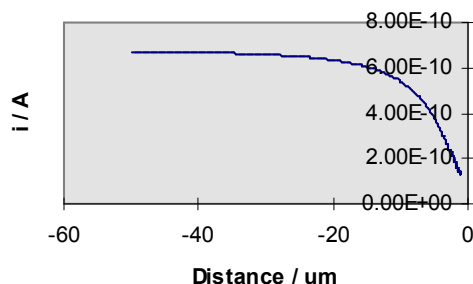

12.13 Model 1000C Series Multi-Potentiostat

The model 1000C series instrument is a computerized eight-channel potentiostat. The system contains a digital function generator and multiplexed data acquisition circuitry. The multi-potentiostat can work with eight independent cells or eight working electrodes in the same solution with common reference and counter electrodes. The potential control range is ± 10 V for all channels and the current range is ± 10 mA. The instrument is capable of measuring current down to picoamperes. Each electrode can be individually controlled, including on/off control, potential, and sensitivity settings; each can be set to an independent potential or the same potential as the primary channel, so that they can sweep or step potentials together with the primary channel.

The model 1000C series is an upgrade to the model 1000/1000A/1000B series. The instrument allows eight independent cells, simultaneous or sequential measurements, fast waveform generation and data acquisition speed (1 MHz @ 16-bit), and easy software update using flash memory.

Many electrochemical techniques are available in this model series, including cyclic voltammetry and amperometric i-t measurements, with all eight channels available (except for open circuit potential measurements). The parameters for all channels must be set before running an experiment; you cannot alter parameter settings during experiments. During a run, you can toggle between single and multi-data set display (parallel or overlay plots). After a run, you can choose data from any channel for parallel or overlay plotting.

Techniques for Model 1000C Series

<i>Techniques</i>	<i>1000C</i>	<i>1010C</i>	<i>1020C</i>	<i>1030C</i>	<i>1040C</i>
CV	•	•	•	•	•
LSV &	•	•	•	•	•
CA				•	•
CC				•	•
DPV &			•	•	•
NPV &			•	•	•
SWV &			•	•	•
ACV &					•
SHACV &					•
FTACV					•
i-t	•	•		•	•
DPA		•		•	•
TPA		•		•	•
SSF				•	•
STEP				•	•
OCPT	•	•	•	•	•

& Corresponding stripping mode can be performed.

Specifications

8-channel potentiostat
 8 independent cells or a multi-WE cell
 Potential range (all channels): ± 10 V
 Applied potential accuracy: ± 1 mV, $\pm 0.01\%$ of scale
 Compliance voltage: ± 12 V
 Current range (each channel): 10 mA
 Reference electrode input impedance: 10^{12} ohm
 Sensitivity scale: 10^{-9} - 0.001 A/V in 7 ranges
 Minimum current resolution: 0.0015% of current

DPV and NPV pulse width: 0.001 to 10 sec
 SWV frequency

- 1 to 100 kHz (sequential scan)
- 1 to 3125 Hz (8 channel simultaneous scan)

ACV frequency

- 1 to 10000 Hz (sequential scan)
- 1 to 312 Hz (8 channel simultaneous scan)

SHACV frequency

- 1 to 5000 Hz (sequential scan)
- 1 to 250 Hz (8 channel simultaneous scan)

range, min 0.3 pA
Input bias current: < 50 pA
Fast waveform update: 5 MHz @ 16-bit
Fast data acquisition: up to 1 MHz @ 16-bit
CV and LSV scan rate

- 0.000001 to 5000 V/s (sequential scan)
- 0.000001 to 25 V/s (8 channel simultaneous scan)
- Potential increment during scan: 0.1 mV @ 1,000 V/s

CA and CC pulse width: 0.0001 to 1000 sec
CA and CC sample interval:

- 1e-6 to 50 s (sequential step)
- 8e-5 to 50 s (8 channel simultaneous step)

FTACV frequency: simultaneously acquire 1st, 2nd, 3rd, 4th, 5th, and 6th harmonics data

- 0.1 to 50 Hz (sequential scan)
- 0.1 to 34 Hz (8 channel simultaneous scan)

Current low-pass filters
Current analog output
Cell control: purge, stir, knock
Data length: 128K - 4096K each channel
Dimensions: 14.2"(W) × 9.2"(D) × 4.7"(H)

12.14 Model 1100C Series Power Potentiostat / Galvanostat

The Model 1100C series power potentiostat/galvanostat is designed for electrochemical applications that require relatively large current and high compliance voltage, such as battery studies, corrosion, electrolysis, and electroplating. The potential control range is ± 10 V, the current range is ± 2 A, and the compliance voltage is ± 25 V. The instrument contains a high speed digital function generator, a fast data acquisition system, current signal filters, iR compensation circuitry, a potentiostat, and a galvanostat (1140C only). The function generator can update at a 10 MHz rate, and the maximum sampling rate is 1 MHz at 16-bit resolution. This series is capable of measuring current down to tens of picoamperes. The 1100C series is capable of measuring current down to tens of picoamperes. The steady state current of a 10 μm disk electrode can be readily measured without external adapters. The instrument provides a very wide dynamic range of experimental time scales. For instance, the scan rate in cyclic voltammetry can be up to 1000 V/s with a 0.1 mV potential increment, or 5000 V/s with a 1 mV potential increment. The potentiostat/galvanostat uses a 4-electrode configuration, allowing it to be used for liquid/liquid interface measurements and eliminating the effect of the contact resistance of connectors and relays for high current measurements. The data acquisition systems allow an external input signal (such as spectroscopic) to be recorded simultaneously with electrochemical data.

Similar features can also be obtained using the combination of the model 600E series and the CHI680C Amp Booster. However, the model 1100C series is more compact and less expensive.

Specifications

Potentiostat	CV and LSV scan rate: 0.000001 to 5000 V/s
Galvanostat (Model 1140C)	Potential increment during scan: 0.1 mV @ 1000 V/s
Potential range: -10 to 10 V	CA and CC pulse width: 0.0001 to 1000 sec
Applied potential resolution: 0.0015 % of potential range	CA and CC Steps: 320
Applied potential accuracy: ± 2 mV, $\pm 0.02\%$ of scale	DPV and NPV pulse width: 0.001 to 10 sec
Potentiostat rise time: $< 2 \mu\text{s}$	SWV frequency: 1 to 100 kHz
Compliance voltage: ± 25 V	CA and i-t sample interval: minimum 1 μs
3- or 4-electrode configuration	ACV frequency: 0.1 to 10 kHz
Current range: ± 2 A	SHACV frequency: 0.1 to 5 kHz
Reference electrode input impedance: 10^{-12} ohm	Automatic potential and current zeroing
Sensitivity scale: 10^{-12} - 0.1 A/V in 12 ranges	Potential and signal low-pass filters (8-decade freq. range, auto/manual)
Input bias current: < 50 pA	Potential and current analog output
Current measurement resolution: < 1 pA	Cell control: purge, stir, knock
Potential update rate: 10 MHz	Flash memory for quick software update
Data acquisition: 16-bit @ 1 MHz	USB or serial port selectable for data communication
External voltage signal recording channel	Data length: 128K - 4096K selectable
External potential input	Chassis dimensions: 14.2"(W) \times 9.2"(D) \times 4.7"(H)
Automatic and manual iR compensation	
Potential and current analog output	
RDE control voltage output: 0-10 V (1130C and up)	

Techniques for Model 1100C Series

Technique	1100C	1110C	1120C	1130C	1140C
Cyclic Voltammetry (CV)	•	•	•	•	•
Linear Sweep Voltammetry (LSV) ^{&}	•	•	•	•	•
Staircase Voltammetry (SCV) ^{#,&}				•	•
Tafel Plot (TAFEL)				•	•
Chronoamperometry (CA)	•		•	•	•
Chronocoulometry (CC)	•		•	•	•
Differential Pulse Voltammetry (DPV) ^{#,&}		•	•	•	•
Normal Pulse Voltammetry (NPV) ^{#,&}		•	•	•	•
Differential Normal Pulse Voltammetry (DNPV) ^{#,&}					•
Square Wave Voltammetry (SWV) ^{&}			•	•	•
AC Voltammetry (ACV) ^{#,&,&}				•	•
2nd Harmonic AC Voltammetry (SHACV) ^{#,&,&}				•	•
Amperometric i-t Curve (i-t)				•	•
Differential Pulse Amperometry (DPA)					•
Double Differential Pulse Amperometry (DDPA)					•
Triple Pulse Amperometry (TPA)					•
Bulk Electrolysis with Coulometry (BE)	•		•	•	•
Sweep-Step Functions (SSF)					•
Multi-Potential Steps (STEP)					•

Chronopotentiometry (CP)					•
Chronopotentiometry with Current Ramp (CPCR)					•
Potentiometric Stripping Analysis (PSA)					•
Open Circuit Potential - Time (OCPT)	•	•	•	•	•
Galvanostat					•
Full version of CV simulator				•	•
Limited version of CV simulator	•	•	•		

Corresponding polarographic mode can be performed.

& Corresponding stripping mode can be performed.

§ Phase-selective data are available.

12.15 Model 1200B Series Handheld Potentiostat / Bipotentiostat

The model 1200B series instrument is a computerized hand-held potentiostat/bipotentiostat. The system contains a digital function generator, a data acquisition system, and a potentiostat/bipotentiostat, and it is well suited for electroanalysis and sensor studies. The potential range is ± 2.4 V and the current range is ± 2 mA. This series is capable of measuring current down to 100 pA. The steady state current of a 10 μ m disk electrode can be readily measured. The size of the instrument is 7" (W) \times 4.5" (D) \times 1" (H), and it is powered through a USB port, without any need for an AC adapter or batteries. The instrument can be used for electroanalysis and sensor studies. Due to its small size, light weight, and low cost, it is particularly useful for field applications and teaching laboratories.

The Model 1200B series allows ± 7.5 V compliance voltage, which ensures its working potential range of ± 2.4 V for most electrochemical systems. It also uses dual 16-bit DAC and 16-bit ADC for high resolution and accuracy.

The model 1200B series potentiostats (12 \times 0B, 1205B, and 1207B) and bipotentiostats (12 \times 2B, 1206B, and 1208B) are offered in several models tailored to meet a wide range of applications and budget levels.

Specifications

Potentiostat / bipotentiostat	CV and LSV scan rate: 0.000001 to 10 V/s
Potential range: -2.4 to 2.4 V	CA and CC pulse width: 0.001 to 1000 sec
Compliance voltage: ± 7.5 V	CA and CC Steps: 1 - 320
Current range: ± 2 mA	DPV and NPV pulse width: 0.001 to 10 sec
Reference electrode input impedance: 10^{-12} ohm	SWV frequency: 1 to 5000 Hz
Sensitivity scale: 10^{-9} - 0.001 A/V in 7 ranges	ACV frequency: 0.1 to 2000 Hz
Input bias current: < 100 pA	Low-pass filter for current measurements
Current measurement resolution: < 1 pA	Data length: 128K - 4096K selectable
Data acquisition: 16 bit @ 1 MHz	Chassis dimensions: 7"(W) \times 4.5"(D) \times 1"(H)

Techniques for Model 1200B Series

Techniques	1200B/ 1202B	1205B/ 1206B	1207B/ 1208B	1210B/ 1212B	1220B/ 1222B	1230B/ 1232B	1240B/ 1242B
Cyclic Voltammetry (CV)*	•	•	•	•	•	•	•
Linear Sweep Voltammetry (LSV) & *	•	•	•	•	•	•	•
Chronoamperometry (CA) *	•				•	•	•
Chronocoulometry (CC)	•				•	•	•
Differential Pulse Voltammetry (DPV) & *				•	•	•	•
Normal Pulse Voltammetry (NPV) & *				•	•	•	•
Differential NPV (DNPV) & *						•	•
Square Wave Voltammetry (SWV) & *					•	•	•
AC Voltammetry (ACV) &							•
2nd Harmonic AC Voltammetry (SHACV) &							•
Amperometric i-t Curve (i-t) *		•	•			•	•
Differential Pulse Amperometry (DPA)			•			•	•
Double DPA (DDPA)			•			•	•
Triple Pulse Amperometry (TPA)			•			•	•
Sweep-Step Functions (SSF)							•
Multi-Potential Steps (STEP)							•
Open Circuit Potential - Time (OCPT)	•	•	•	•	•	•	•
Full version of CV simulation / fitting						•	•
Limited version of CV simulation / fitting	•	•	•	•	•		

& Corresponding stripping mode can be performed.

* Second channel (bipotentiostat mode) can be performed.

Note: 12 \times 0B, 1205B, and 1207B are single potentiostat models; 12 \times 2B, 1206B, and 1208B are bipotentiostat models.

12.16 Pico-Liter Solution Dispenser

The CHI1550A solution dispenser is designed for making high density and high accuracy solution arrays, which can be used in a wide variety of chemical, biological, and medical applications. The solution dispenser consists of a high-resolution three-dimensional positioner, a piezoelectric jetting device, and a sample platform, as shown in the Figure below.

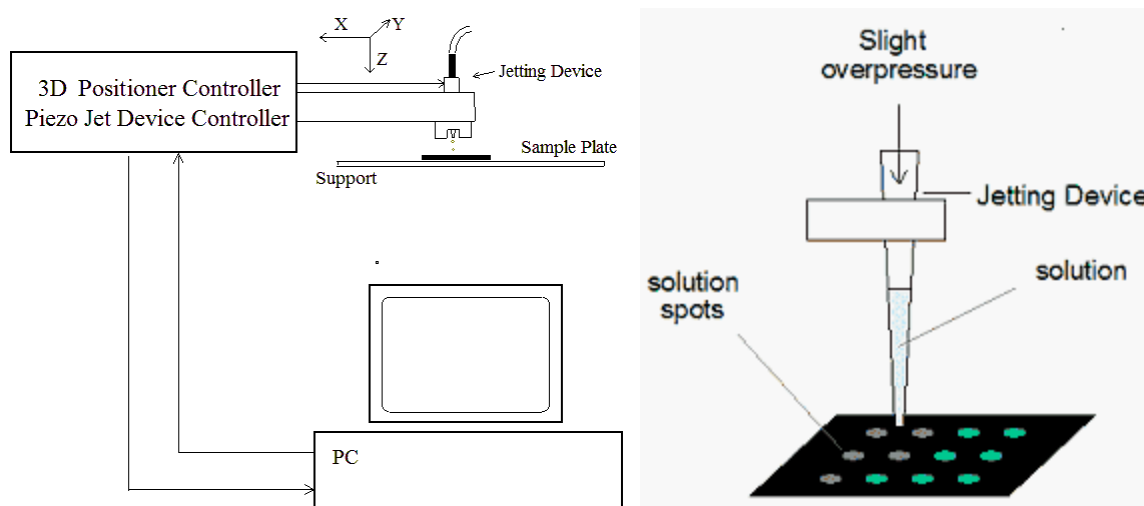

Figure. Diagram of the solution dispenser

The three-dimensional positioner can travel a distance of 50 mm in all three directions with 0.1 micrometer resolution, allowing high-precision patterning. This is particularly important when multiple overlapping solution components need to be dispensed.

The jetting device can dispense single drops of solutions with viscosity less than 40 centipoise and surface tension in the range of 0.02-0.07 N/m. Solutions with properties outside these limits can be jetted if changes to the properties can be achieved with solvents or changes in temperature. With a default nozzle size of 60 microns, the jetting device can produce drops ranging from 100-200 picoliters in volume, depending on the operating parameters and solution composition.

The CHI1550A solution dispenser control software is very user-friendly for creating binary, ternary, and quaternary arrays of spots containing mixtures of solutions. Instead of using a manually created look-up table for solution dispensing patterns, pattern creation is facilitated by our software, which can also provide commonly used patterns as a default for binary, ternary, and quaternary arrays. The positioner can memorize certain critical positions, such as the solution loading point and first dispensing point, allowing the jetting device to go to these positions easily and quickly.

The array pattern can be examined graphically, and it will also be displayed during the dispensing process.

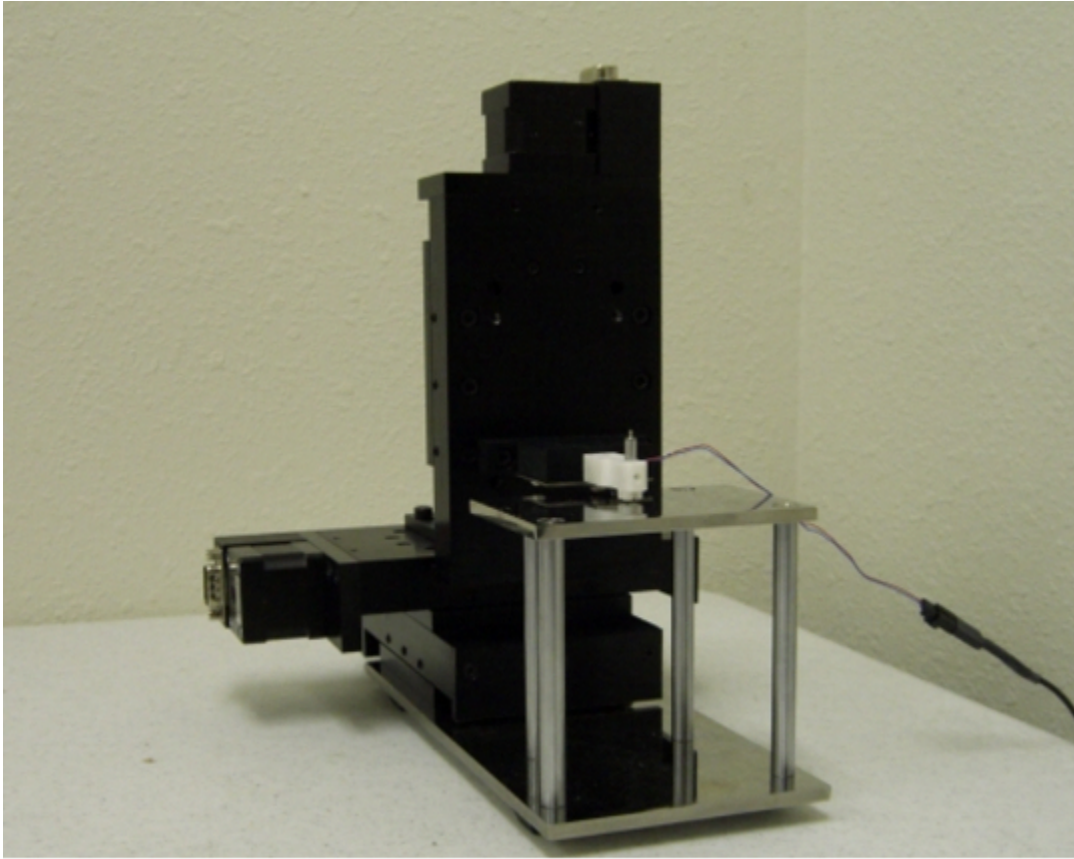

Figure. Micropositioner and sample stand

System requirements

Operating System: Windows 95 / 98 / NT / Me / 2000 / XP / Vista / 7 / 8

Communication between PC and instrument: USB or RS-232 serial port

Hardware Specifications

Micropositioner:

Three high-resolution stepper motors

- Maximum range of motion: 50 mm
- Motor resolution: 8 nm
- Stall Load: 50 N
- Maximum Speed: 4 mm / sec

Three translation stages

- Maximum range of motion: 25 mm
- Angular deviation: < 200 microrad
- Load capacity: 156 N
- Load capacity (vertical): 67 N

Jetting Device:

Nozzle: 60 microns
Droplet size: 100-200 picoliters
Control voltage: 0 - 150 V
Protective holder

12.17 Picoamp Booster/Faraday Cage and Multiplexer

CHI200(B) Picoamp Booster and Faraday Cage

With the CHI200(B) Picoamp Booster and Faraday Cage, current down to a few picoamperes can be readily measured. The CHI200 is compatible with the model 600/A, 700/A series of instruments, while the CHI200B is compatible with the model 600B/C/D/E and 700B/C/D/E series. When used with the 700/A/B/C/D/E series bipotentiostat, the Picoamp Booster will affect only the primary channel.

The internal sensitivity of the 600E series is the same as the Picoamp Booster (10^{-12} A/V). However, the bias current of the 600E series input can be as high as 50 pA. The Picoamp Booster has a lower bias current, and it also brings the preamplifier close to the electrode, resulting in lower noise. The Faraday cage also makes it possible to make relatively fast measurements of small currents.

When the Picoamp Booster is connected and the sensitivity scale is at or below $1e-8$ A/V, the Picoamp Booster will be automatically enabled. Otherwise it will be disabled. Detection and enabling/disabling of the Picoamp Booster are fully automatic and do not require user intervention.

The Picoamp Booster will be disabled for techniques using automatic sensitivity switching, such as Tafel plots (TAFEL) and bulk electrolysis (BE), and galvanostatic techniques. For galvanostatic techniques, such as chronopotentiometry (CP), chronopotentiometry with Current Ramp (CPCR), Multi-Current Steps (ISTEP), and Potentiometric stripping analysis (PSA), the Picoamp Booster will not work. However, it works with AC impedance (IMP).

In addition to allowing weak signal measurements, the Faraday cage is useful for eliminating electrical interference, especially line frequency noise. If the electrochemical cell is picking up electrical noise from the environment, the additional use of the Faraday cage is strongly recommended.

Before connecting the Picoamp Booster, turn the instrument power off. Connect the Picoamp Booster to the 6-pin "Electrodes" connector on the rear panel of the instrument. Also connect the DB-25 connector of the Picoamp Booster to the "Cell Control" connector on the rear panel of the instrument with the straight through DB-25 cable (included), then turn the instrument power on.

The DB-25 connector provides power and control lines (see Cables and Connections in the Appendix). When the DB-25 connector is disconnected, you can still do experiments with the Faraday cage, although the Picoamp Booster will be disabled.

To purge inert gas, unscrew one of the screws on the back of the faraday cage to open a hole for inert gas tubing.

When the Picoamp Booster is not in use, please disconnect the DB-25 cable.

CHI684 Multiplexer

The CHI684 is a multi-channel multiplexer for the model 400/A/B, 600A/B/C/D/E, 700A/B/C/D/E, 800B/C, 900B/C/D, and 1100A/B/C series. The multiplexer switches four lines (working, sensing, reference, and counter for single-channel potentiostats; working, 2nd working, reference, and counter for bipotentiostats). You can have up to 64 cells, but only one cell can be connected at a time.

The multiplexer is controlled using the Multiplexer command under the Control menu. You can select any channel(s) and run experiments in a sequence of selected channels. Data will automatically be saved to file after each run. You can also be prompted before each channel run.

Arbitrary channels can be set immediately. An experiment can then be run for that particular channel.

Two Macro commands are available for the multiplexer. One is "mch:###", which allows the user to choose an individual channel. The other macro command is "mchn". This is used in a For...Next loop to select the channel according to the For...Next loop counter.

The minimum number of channels for the CHI684 is 8. The channel increment is 8. The maximum number of channels is 64.

12.18 Amp Booster and Liquid/Liquid Interface Adapter

CHI680C Amp Booster

With the CHI680C Amp Booster, current can be measured up to 2 A. The CHI680 is compatible with our Model 600/A/B/C/D series instruments. The CHI680C is compatible with our Model 600D/E series of instruments. You can stack the CHI600D/E and the CHI680C together. The CHI680C can also be connected to the model 700E series, but it will only work for the primary channel.

When the Amp Booster is connected, cell control signals such as purge, knock, and stir will be disabled.

The Amp Booster will also allow low current measurements. You may need to use a Faraday cage to eliminate line frequency noise when the scan rate is above 50 mV/s.

The frequency response of the Amp Booster is somewhat lower than that of the 600/A/B/C/D/E. For high speed experiments, the Amp Booster should be disconnected.

Before connecting the Amp Booster, turn the instrument power off. Connect the 6-pin connector of the Amp Booster to the "Electrodes" connector on the rear panel of the CHI6××D. Also connect the "Cell Control" ports of the Amp Booster and the instrument with a straight through DB-25 cable (included). You can then turn the power on for both the instrument and the Amp Booster. It is generally good practice to turn the instrument on before the Amp Booster, and to turn the Amp Booster off before the instrument.

The cell connector is a 6-pin connector with four cell leads. The green, white, and red clips correspond to the working, reference, and counter electrodes, respectively. The black clip is for the sensing electrode of the 4-electrode configuration, which can be turned on or off with the "4 Electrodes" box using the Cell command under the Control menu. When the 4-electrode option is on, you should connect the sensing lead to the working electrode (short the green and black leads together). The 4-electrode configuration is useful for liquid/liquid interface or high current measurements. It helps eliminate the resistance (about 0.2-0.3 ohms) due to the connectors, relays, and printed circuit board traces.

If you think there might be something wrong with the hardware, please conduct a hardware test with the Amp Booster disconnected. If the instrument passes the test, then connect the Amp Booster and test it with a standard resistor. For instance, conduct a CV experiment and verify that a straight line with a slope of voltage / resistance is correctly obtained.

CHI682 Liquid/Liquid Interface Adapter

Liquid/liquid interface studies are very important in applications involving charge transfer, chemical sensing, drug release, and solvent extraction, among others. This typically involves two reference electrodes and two auxiliary electrodes. The modified potentiostat controls the potential difference between two reference electrodes in two phases, while measuring the current passing through two auxiliary electrodes. The CHI682 Liquid/Liquid Interface Adapter is compatible with our model 700A series. It is fully automatic and user-friendly. Most electrochemical techniques can be used, albeit without galvanostat or bipotentiostat functions.

This is a legacy accessory for the model 700A series. Liquid/liquid interface measurement capabilities using 4-electrode configuration are built into our model 400/A/B, 600A/B/C/D, 700B/C/D, 800B/C, 900B/C, and 1100/A/B series instruments, with no need for the CHI682 Liquid/Liquid Interface Adapter.

12.19 Accessories

Part No.	Description	Unit
CHI101	2 mm dia. Gold Working Electrode	1
CHI101P	2 mm dia. Gold Working Electrode	3/pk
CHI102	2 mm dia. Platinum Working Electrode	1
CHI102P	2 mm dia. Platinum Working Electrode	3/pk
CHI103	2 mm dia. Silver Working Electrode	1
CHI104	3 mm dia. Glassy Carbon Working Electrode	1
CHI104P	3 mm dia. Glassy Carbon Working Electrode	3/pk
CHI105	12.5 µm dia. Gold Microelectrode	1
CHI105P	12.5 µm dia. Gold Microelectrode	3/pk
CHI106	25 µm dia. Gold Microelectrode	1
CHI106P	25 µm dia. Gold Microelectrode	3/pk
CHI107	10 µm dia. Platinum Microelectrode	1
CHI107P	10 µm dia. Platinum Microelectrode	3/pk
CHI108	25 µm dia. Platinum Microelectrode	1
CHI108P	25 µm dia. Platinum Microelectrode	3/pk
CHI111	Ag/AgCl Reference Electrode	1
CHI111P	Ag/AgCl Reference Electrode	3/pk
CHI112	Non-Aqueous Ag/Ag+ Reference Electrode 1	1
CHI112P	Non-Aqueous Ag/Ag+ Reference Electrode 1	3/pk
CHI115	Platinum Wire Counter Electrode	1
CHI116	10 mm dia. Platinum SECM Tip	1
CHI116P	10 mm dia. Platinum SECM Tip	3/pk

Part No.	Description	Unit
CHI117	25 µm dia. Platinum SECM Tip	1
CHI117P	25 µm dia. Platinum SECM Tip	3/pk
CHI120	Electrode Polishing Kit ²	1
CHI125A	Polished, Bounded, Mounded 100A Ti + 1000 A Gold Crystal for EQCM	1
CHI127	EQCM Cell	1
CHI128	Reference Electrode for EQCM Cell	1
CHI129	Pt Wire Counter Electrode for EQCM Cell	1
CHI130	Thin-Layer Flow Cell	1
CHI131	GC Working Electrode for Flow Cell	1
CHI132	Au Working Electrode for Flow Cell	1
CHI133	Pt Working Electrode for Flow Cell	1
CHI134	Reference Electrode for Flow Cell	1
CHI135	25 µm Spacer for Flow Cell	4/pk
CHI140A	Spectroelectrochemical Cell	1
CHI150	Calomel Reference Electrode	1
CHI151	Mercury/Mercurous Sulfate Reference Electrode	1
CHI152	Alkaline/Mercurous Oxide Reference Electrode	1
CHI172-Model #	Electrode leads for a particular instrument model number	1
CHI200	Picoamp Booster and Faraday Cage ³	1
CHI201	Picoamp Booster	1
CHI202	Faraday Cage	1
CHI220	Simple Cell Stand ⁴	1
CHI221	Cell Top (including Pt wire counter electrode, not a replacement part for the CHI200 cell stand) ⁵	1
CHI222	Glass Cell	1
CHI223	Teflon Cap ⁵	1

Notes:

1. Ag⁺ solution (typically 10 mM) should be prepared with the supporting electrolyte and AgNO₃ (not included) and filled into the reference electrode compartment using a syringe (not included). Detailed instructions are included with the components.
2. The electrode polishing kit contains 1 bottle of 1.0 micron Alpha alumina powder, 1 bottle of 0.3 micron Alpha alumina powder, 3 bottles of 0.05 micron Gamma alumina powder, 2 glass plates for polishing pads, 5 pieces of 73 mm diameter 1200 grit CarbiMet disks (grey-colored), 5 pieces of 73 mm diameter Mastertex polishing pads (white-colored), and 10 pieces of 73 mm diameter Microcloth polishing pads (brown-colored).
3. The Picoamp Booster and Faraday Cage allow current measurements down to 1 pA. Usage is fully automatic and compatible with our model 600E and 700E series instruments (primary channel only).
4. Made of stainless steel and Teflon. Not remote controllable. Four glass cells are included.
5. Not a replacement part for the CHI220 Cell Stand.

